



NMB Minebea
Spherical, Rod End
and Sleeve Bearings

„Inch“



NMB Minebea Spherical, Rod End

and Sleeve Bearings

„Inch“

Minebea A380 Applications

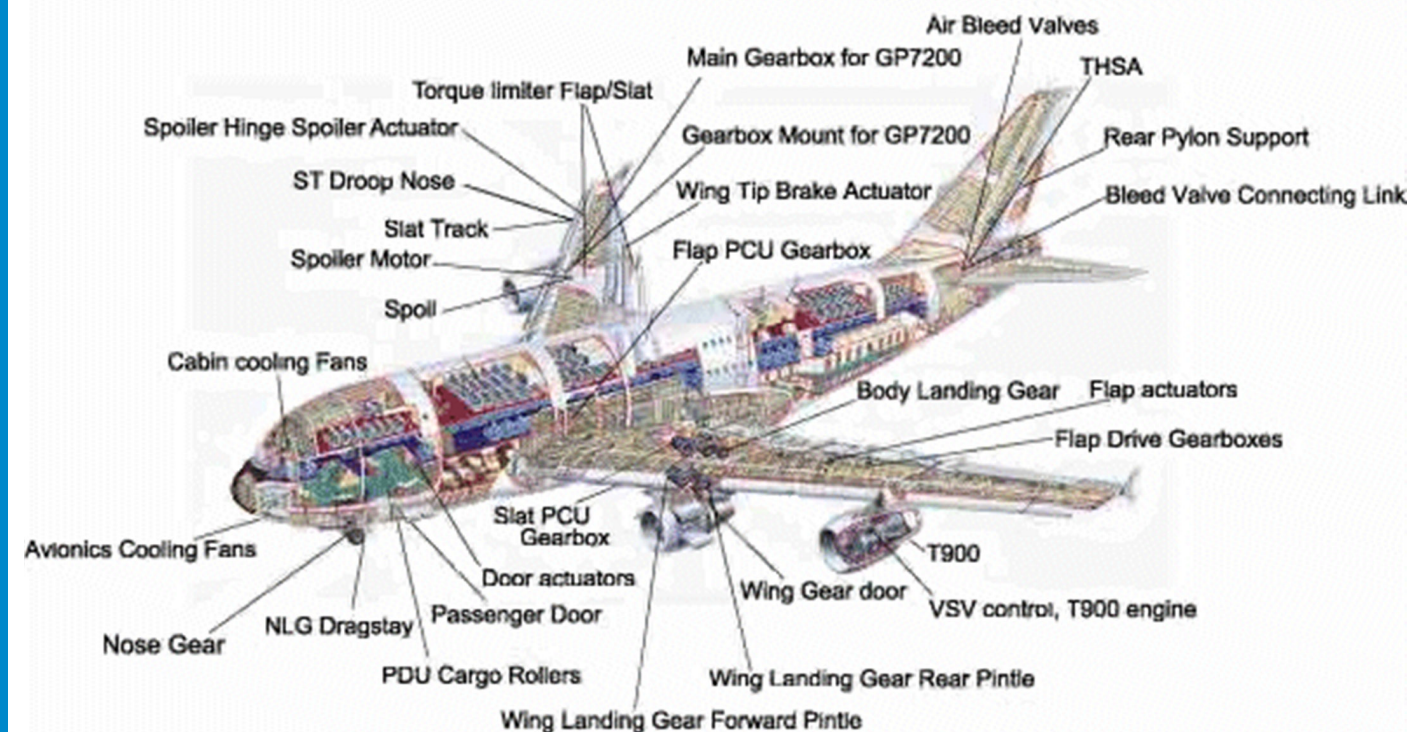

BEARING CLASSIFICATIONS

Bearings are divided into two basic categories:

(1) rolling element or "anti-friction" bearings.

(2) sliding surface or "plain" bearings. Except as noted, all bearings in this guide are of the "plain" bearing classification.

TABLE 1 - NMB BEARING CLASSIFICATION BY CONSTRUCTION ELEMENTS

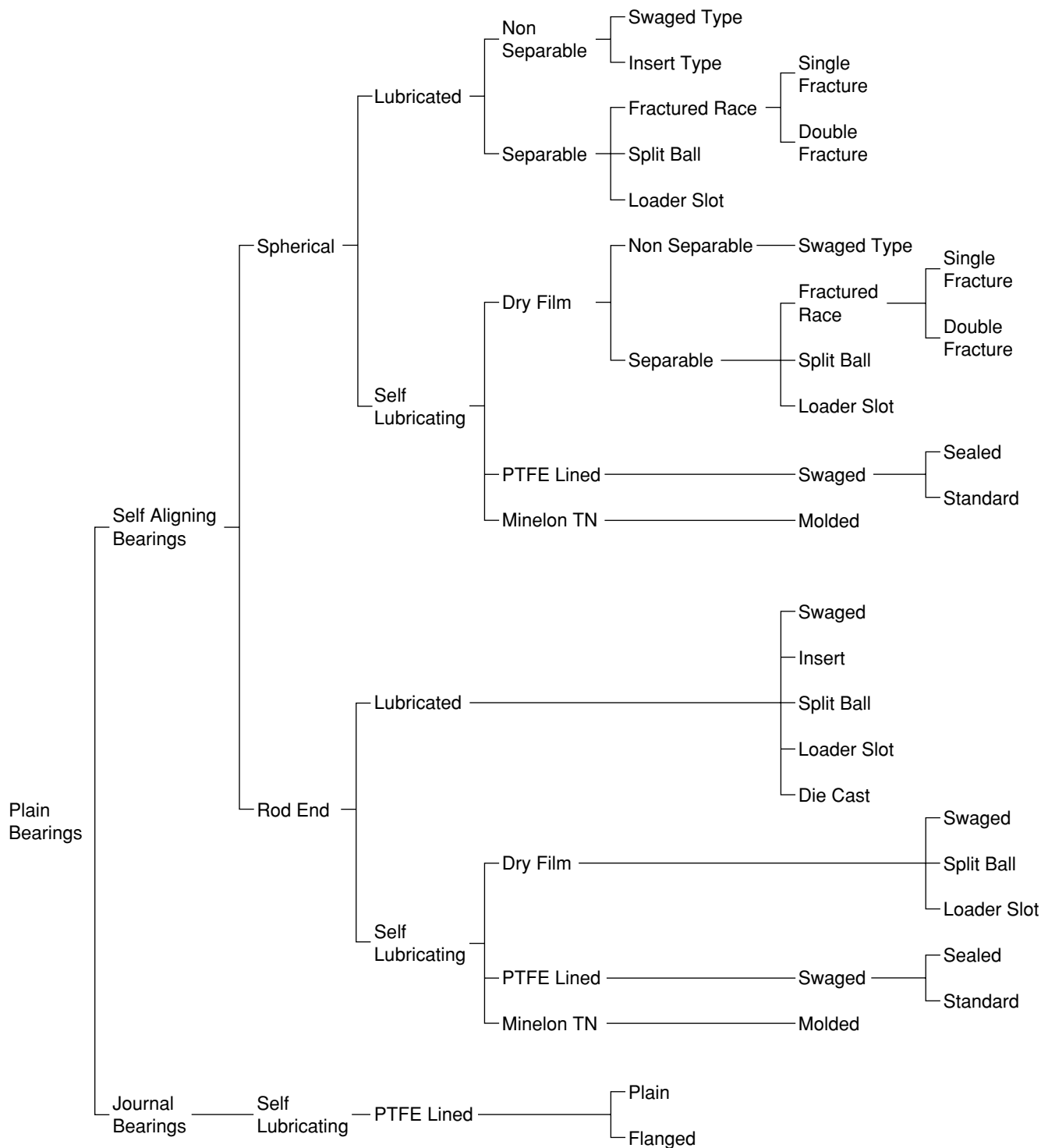

Rolling Element Bearings

Engineering information on rolling element (anti-friction) bearings is presented in other NMB publications except that self-aligning, anti-friction, double row, ball bearing rod end data is included in this guide. (See page 10).

BEARING CLASSIFICATIONS

TABLE 2 - NMB CATALOG BEARING SERIES BY CLASSIFICATION
(Bearing Series listed include both aircraft and commercial types)

CLASSIFICATION		INCH SERIES				METRIC SERIES	
SPHERICAL BEARINGS	Metal / Metal	ABG ABW ABK ABC-G ABC-VA	ABG-V ABW-V ABK-V ABC-VG ABC-GA	HABG ABY HABK ABB ABC-VGA	HABG-V ABY-V HABK-V ABB-S AM	MBG-CR MBW-CR MBY-CR SBH SBW	MBG-VCR MBW-VCR MBY-VCR SBWH
	PTFE lined	ABT ABYT HTY HTL	ABT-V ABYT-V HTY-V HTL-V	ABWT HT WHT WHTL	ABWT-V HT-V WHT-V WHTL-V	SBT MBT-V MBWT-V MBYT-V	MBT MBWT MBYT
	Minelton TN	N/A				BM	
2 PIECE ROD ENDS	Metal / Metal	AHM	AHF			N/A	
	PTFE lined	AHMT	AHFT			RBT-E	RBT
3 PIECE ROD ENDS	Metal / Metal	AR ARYM AMM	AR-E ARYF AMF	ARH ARB	ARH-E ARB-E	HR-E HRH-E	HR HRH
	PTFE lined	ART ARYT ARNM	ART-E ARYT-E ARNF	ARHT ANM	ARHT-E ANF	HRT-E HRHT-E	HRT HRHT
4 PIECE ROD ENDS	Metal / Metal (insert type)	CAMR	CAFR	AMR	AFR	PR-E	PR
DIE CAST ROD ENDS	Metal / Metal	N/A				ER	
MOLDED RACE ROD ENDS	Minelton TN	CAMMR	CAMFR			RBM-E	RBM
JOURNAL BEARINGS	PTFE lined	AJ	AJF	AHJ	AHJF	MJ	MJF
BALL BEARING ROD ENDS	(Anti-friction)	ABR-M	ABR-F	ABR-H	ABR-S	PBR-E	PBR
•ROLLER BRGS	(Anti-friction)	ASR	ASRD	ASRDG.ASRDF	ASRD-V	N/A	
•ROLLER BRG ROD ENDS	(Anti-friction)	ARR-FFN ARR-SFN ARRDE-M	ARR-MFN ARRD-HFN	ARR-MFN-3 ARRD-SFN	ARR-HFN ARRE-M	N/A	

BEARING TYPES AND DETAILS OF CONSTRUCTION

ENGINEERING DATA

NMB manufactures a wide range of spherical bearings and rod ends for both commercial and aerospace applications. Figures 1 through 6 show examples of 2-piece, 3-piece and 4-piece rod ends with configurational variations. All rods end shown are manufactured in both male and female versions. The metal-to-metal rod ends can be furnished with dry film lubricant coatings or, when size permits, be provided with grease lubrication grooves, holes and flush type or zerk type fittings. In general, lube fittings cannot be furnished on rod ends with bores of less than .250" (6.35mm).

RODS ENDS

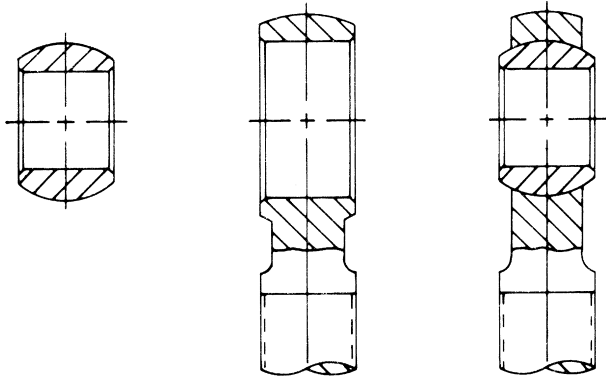

FIGURE 1 - 2- PIECE, SWAGE-COINED ROD END

Figure 1 illustrates a 2-piece swage coined rod end. The head of the rod end is coined or swaged around the ball and thus serves as the outer race. This type of rod end is generally used in static applications when maximum strength in a given envelope is required. By virtue of its design, however, the 2-piece coined rod ends has relatively poor ball to race conformity, particularly in the 6 o'clock area, and Teflon liners are not recommended. On the other hand, the simplicity of its design permits this type of rod end to be manufactured in miniature sizes with bores as small as .0469" (1.191mm).

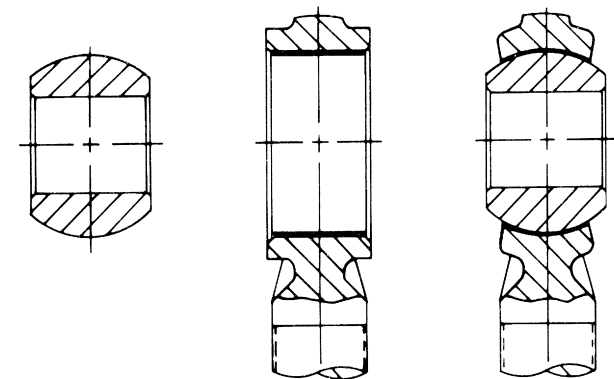

FIGURE 2 - 2- PIECE, MOHAWK ROD END

Figure 2 represents Mohawk configuration. The Mohawk 2-piece design is an economical rod end serving a broad spectrum of commercial application. Figure 2 shows the configuration used for Teflon lined Mohawks. This design has good ball to race conformity and can be used in dynamic applications when loads are relatively light.

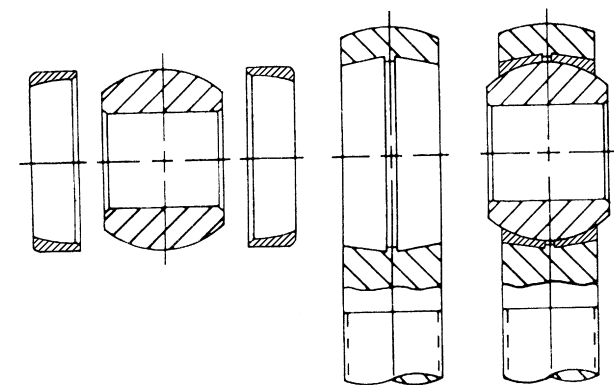

FIGURE 3 - 4- PIECE, INSERT-TYPE ROD END

Figure 3 shows a 4-piece insert-type rod end construction. This configuration sees wide usage in commercial and general aviation applications. As catalog items, they are furnished with zinc or cadmium plated steel bodies having an ultimate tensile strength of 82.5ksi (569 N/mm²), ball of through hardened bearing steel, chrome plated, and inserts of either copper alloy or 300 series stainless steel. 4-piece rod ends can be furnished with re-lubrication provisions, but are not available with Teflon liners.

BEARING TYPES AND DETAILS OF CONSTRUCTION

Figure 4 and 5 show 3-piece rod ends with 2 types of insert retention. All bearings shown can be furnished in grease lubricated, dry film lubricated or Teflon lined versions. The V-groove staked design illustrated in Figure 4 is the most widely used configuration in aerospace applications. Three V-groove types covering inch bearing sizes 3 through 24 have been standardized by MS bearing and rod end specifications. The V-groove is machined into the race face after swaging. The outer lip formed by this groove is flared over the housing chamfer. This method provides moderate thrust capacity and allows a worn bearing to be removed and replaced with no damage to the housing.

Figure 5 illustrates a housing stake configuration. This method is generally used only when there is insufficient space on the race face for a V-groove, or when other factors such as non-ductile race material. Race shear strength or economy of production are considered.

Figure 6 shows a rod end design using the reverse Messerschmidt principle. The ball is not fractured but machined and ground in matched sets with zero gap at the separation plane. The body is usually of hardened CRES, the ball of copper alloy. Worn balls can be removed manually and replaced. Maximum body strength and bearing projected area results from the fact that loader slots are omitted.

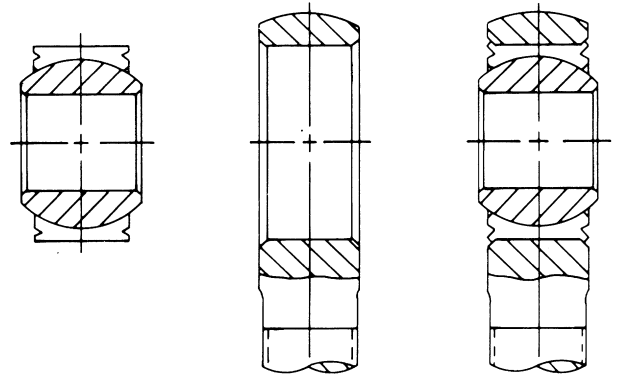

FIGURE 4 - 3- PIECE, V-GROOVE STAKED ROD END

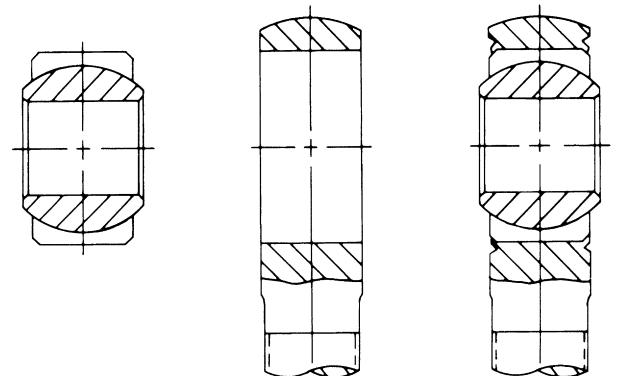

FIGURE 5 - 3- PIECE, HOUSING STAKED ROD END

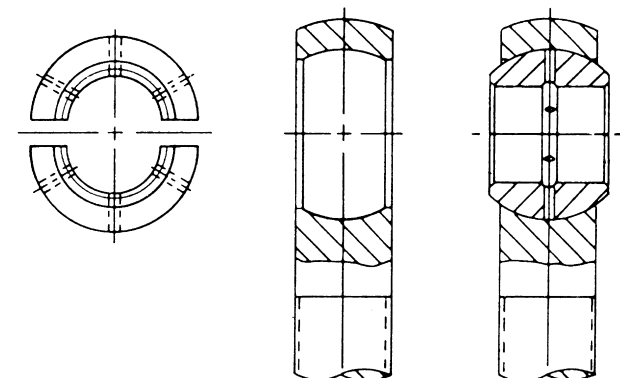
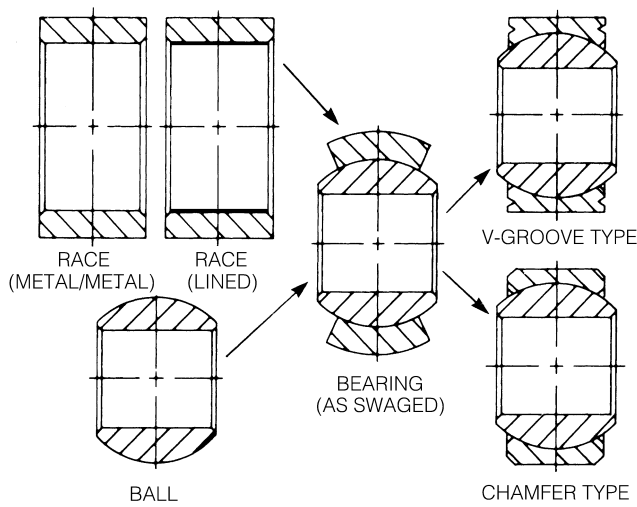

FIGURE 6 - 2- PIECE, SPLIT BALL ROD END

BEARING TYPES AND DETAILS OF CONSTRUCTION

ENGINEERING DATA



SPHERICAL BEARINGS

Figure 7 illustrate the procedures used in manufacturing a standard type swaged spherical bearing. The finished ball is inserted into the cylindrical race blank by slip fit and installed into the assembly die. After removal from the die, the race O.D. is spherical in shape as shown in the “As Swaged” view. At this stage, the ball and race are locked firmly, together and incapable of relative movement. Following subsequent machining, the bearing assembly is released (loosened) to the torque or radial clearance required and the O.D. is then ground to the finished size.

FIGURE 7 - SWAGED SPHERICAL BEARING

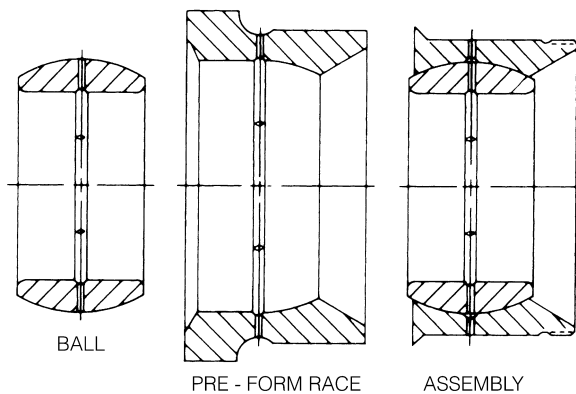

Figure 8 demonstrates an alternative swaging method used when the bearing geometry precludes or renders impractical the double swaging method shown in figure 7. The pre-form design is used when the bearing outer race is not symmetrical about the spherical centerline due to a flange or a wide overhang on one side or a combination of both. In such case, the problem side of the race is pre-formed by machining and grinding and the opposite side only is swaged.

FIGURE 8 - SWAGED PRE - FORM BEARING

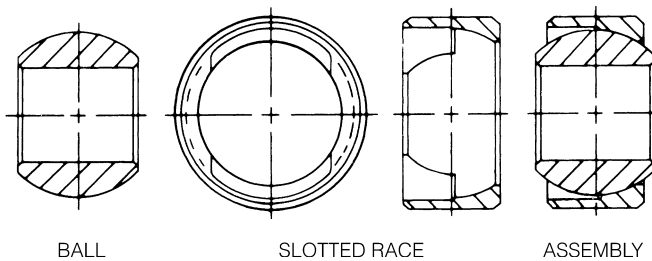

Figure 9 shows a loader slot, or “Messerschmidt” bearing design. This is a non-swaged bearing type. The spherical I.D. is machined and then precision ground after hardening. The loader slots are profile milled prior to heat treatment. This design permits the ball to be inserted and removed manually in the field without need of tooling. Additional advantages of this design are that extremely close tolerance radial and axial clearances can be attained, and very high strength materials and surface coatings can be used on the outer race. A major disadvantage of the design is the need to properly orient the slots with respect to the applied loads due to the loss of bearing projected area. In addition, it is difficult to retain grease and exclude contaminants unless the loader slots are sealed.

FIGURE 9 - LOADER SLOT BEARING

BEARING TYPES AND DETAILS OF CONSTRUCTION

ENGINEERING DATA

Figure 10 illustrates a double fractured race bearing. This type of bearing can be furnished in either a single or double fractured configuration. The retaining ring groove is provided only on the double fractured race design and serves as a recess for a retaining wire or spring which holds the race halves together to facilitate handling until the bearing is installed into its housing. Both race and ball are made of bearing steel, through hardened and precision ground. All surfaces of the ball and race coated with zinc phosphate and a dry film of molybdenum disulfide (MoS_2). In addition, lube grooves and lube holes are provided to permit relubrication through either the housing or shaft. For corrosive environments, balls and races of through hardened stainless steel can be furnished. NMB manufactures catalog series of single and double fractured race bearings in both inch and metric sizes. Nitrile rubber (NBR) seals can be provided as option for all sizes.

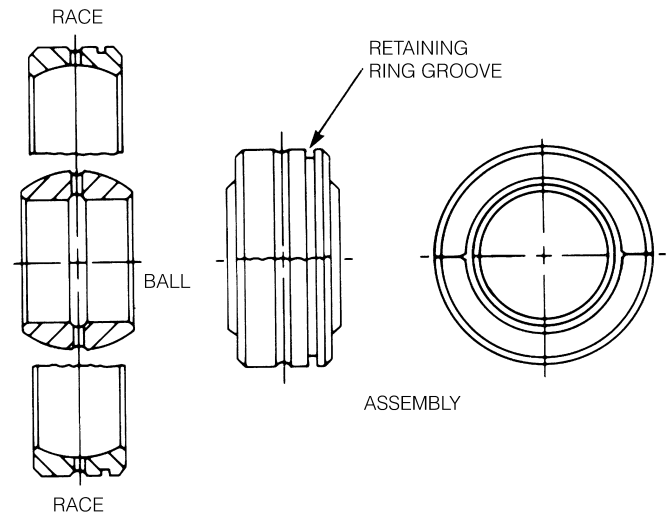

FIGURE 10 - FRACTURED RACE BEARING

Figure 11 shows two examples of snap-assembled or “pop-in” bearing configurations. When component geometry permits (a relatively large diameter, thin section, narrow ball and race), a bearing may be snap-assembled. Snap-assembly is accomplished by deflecting the race, ball, or both within their elastic limits to allow entry of the ball into the race. This type of design is generally used only when all other methods are impractical or impossible due to problem geometry or processing restraints.

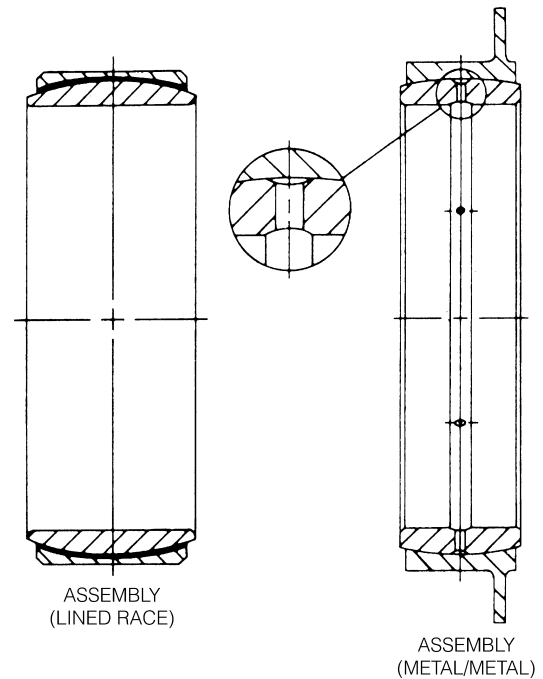

FIGURE 11 - SNAP-ASSEMBLED BEARINGS

BEARING TYPES AND DETAILS OF CONSTRUCTION

ENGINEERING DATA

JOURNAL BEARINGS (SELF-LUBRICATING) MS SERIES

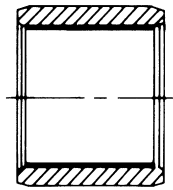
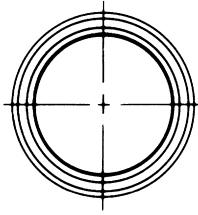

FIGURE 12 - PLAIN, TEFLON LINED

Figure 12 shows the NMB AJ and AHJ series which are approved for procurement to MS21240 and MS81934/1 series respectively.

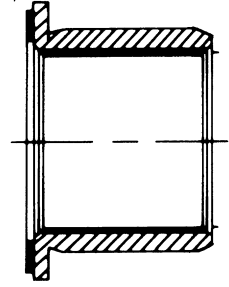
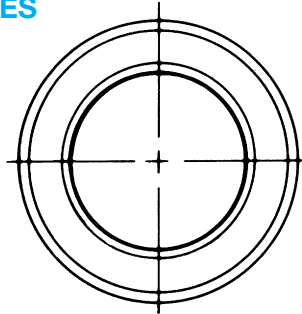
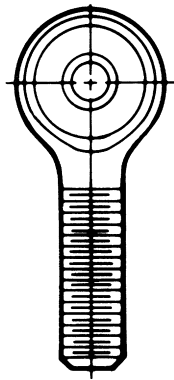
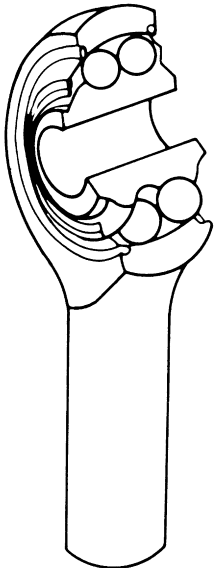

FIGURE 13 - FLANGE, TEFLON LINED

Figure 13 shows the NMB AJF and AHJF series which are approved for procurement to MS21241 and MS81934/2 series respectively.

ROD END BEARINGS - AIRFAME (ANTI-FRICTION) SERIES



MS21151

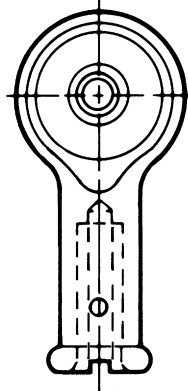

MS21153

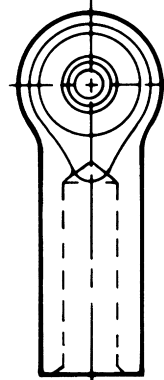

MS21152

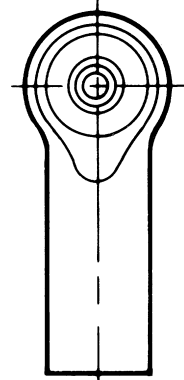

MS21150

FIGURE 14 - DOUBLE ROW, BALL, ROD END PRECISION SERIES

Figure 14 shows internal construction of a double row ball bearing rod end. Ball bearing rod ends are typically used for low load, low friction, dynamic applications. Configuration permits bearing misalignment to 10° in either direction. Inner rings and balls are made of 52100 steel with bodies made of 4130 steel or 8620 steel. Bearings are cadmium plated for corrosion protection and prepacked in grease. NMB ball bearing rod ends are approved for procurement to AS6039 and MS21150, MS21151, MS21152, and MS21153.

ROLLER BEARINGS (SELF - ALIGNING) MS SERIES

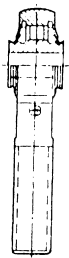

MS21221
MS21223

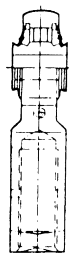

MS21220

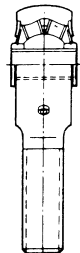

MS21429

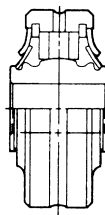

MS21431

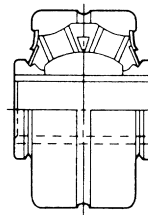

MS28913
MS28914

Figure 15 shows various MS series of roller bearing rod ends and bearings NMB roller bearings are approved for procurement to AS8952 & AS8914 and MS21221, MS21223, MS21220, MS21429, MS21431, MS28913 and MS28914.

SELF-LUBRICATING LINER SYSTEMS

ENGINEERING DATA

TEFLON* OR POLYTETRAFLUOROETHYLENE

(PTFE) - has good wear and excellent low friction properties and makes the ideal bases for a self lubricating liner. However, pure PTFE has a very low strength and must therefore be reinforced in some way to produce an acceptable load carrying surface.

NMB Teflon liners have a woven textile backing (such as Glassfiber, Dacron or Nomex) to give required strength, with a PTFE fiber interwoven to provide the self lubricating properties. The PTFE fiber is concentrated towards the front of the liner where the low wear and self lubricating properties are required, with the majority of the reinforcing textile fiber at the back to ensure a good bonding surface. The liner is impregnated with Phenolic resin for added strength. (See Figure 16). A thermosetting bonding agent applied under temperature and pressure ensures a good bond between the liner and the base metal.

SOME CHARACTERISTICS OF THE PTFE LINER

1. Modulus of elasticity: 4.5×10^5 psi. (3.1×10^5 N/cm²)
2. Coefficient of thermal expansion: 11.6×10^{-6} in/in/°F. (20.9×10^{-6} mm/mm/°C)
3. Low coefficient of friction ranging from approximately .02 to .10. As shown in Figure 17, the coefficient decreases as load and temperatures increase. However the coefficient also increases as surface speed and mating surface roughness increase.
4. Noiseless in operation.
5. Is non-corrosive.
6. Resistant to most chemicals, greases and oils, however wear rates may increase when movement takes place under contaminated conditions.
7. Is non-conductive and non-magnetic.
8. After an initial run-in period, wear rates remain low and relatively constant.
9. Can continue to function satisfactorily with wear as high as .010" (0.25mm).

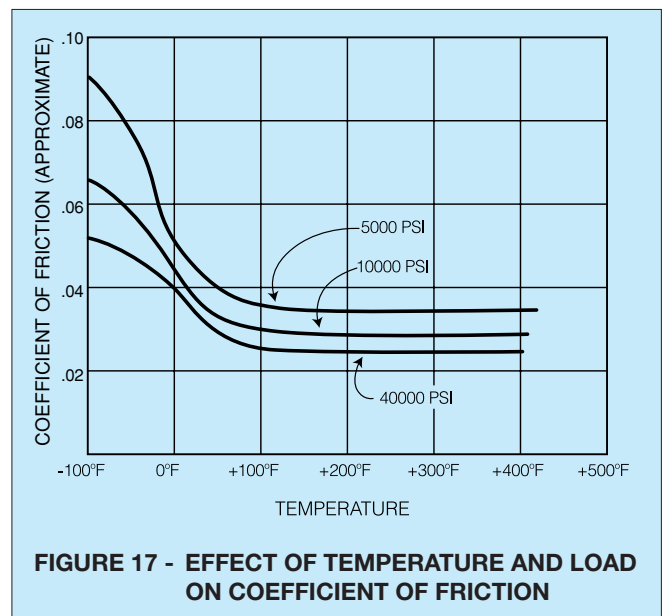
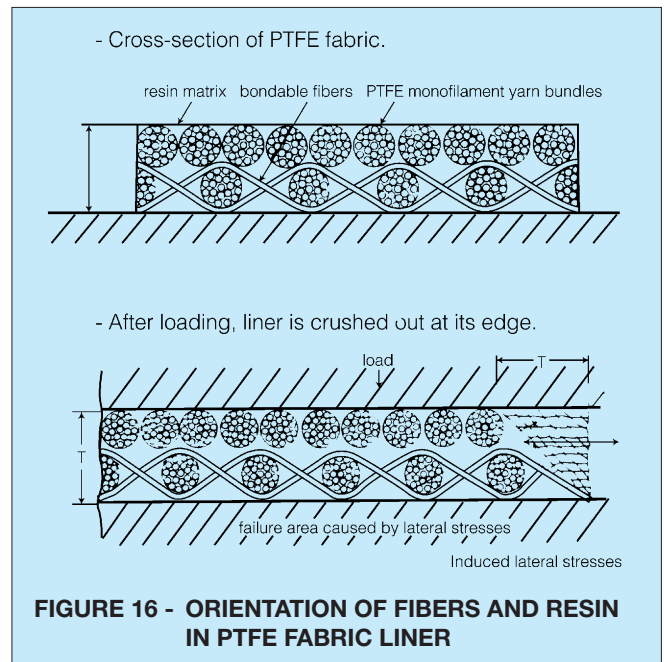

* A trade name of E.I. duPont de Nemours & Co., Inc

SELF-LUBRICATING LINER SYSTEMS

TABLE 3 - CHARACTERISTICS OF FOUR PRINCIPAL NMB LINER SYSTEMS

NMB LINER DESIGNATION	X-1118	X-1276	X-1276F	X-1820
Mil Specs	MIL-B-8942 MIL-B-8943			MIL-B-81820 MIL-B-81934
Backing Material	Glass Fiber	Dacron*	Dacron*	Nomex*
Thickness (ref.)	.0100"-.0114" (0.25-0.29mm)	.0118"-.0134" (0.30-0.34mm)	.0134"-.0150" (0.34-0.38mm)	.0134"-.0150" (0.34-0.38mm)
Temperature Range	-65° - +250°F (-54° - +121°C)	-65° - +250°F (-54° - +121°C)	-65° - +250°F (-54° - +121°C)	-65° - +325°F (-54° - +163°C)
Static Limit Load	69,900 psi (482N/mm ²)	69,900 psi (482N/mm ²)	69,900 psi (482N/mm ²)	78,500 psi (541N/mm ²)
Dynamic Load Capacity	31,900 psi (220N/mm ²)	31,900 psi (220N/mm ²)	31,900 psi (220N/mm ²)	39,900 psi (275N/mm ²)
Friction Coefficient	0.03-0.10	0.03-0.10	0.05-0.15	0.05-0.15

* A trade name of E.I. duPont de Nemours & Co., Inc.

FIGURE 18 - TYPICAL WEAR RATES OF NMB LINERS

LINER TYPE:
X-1820

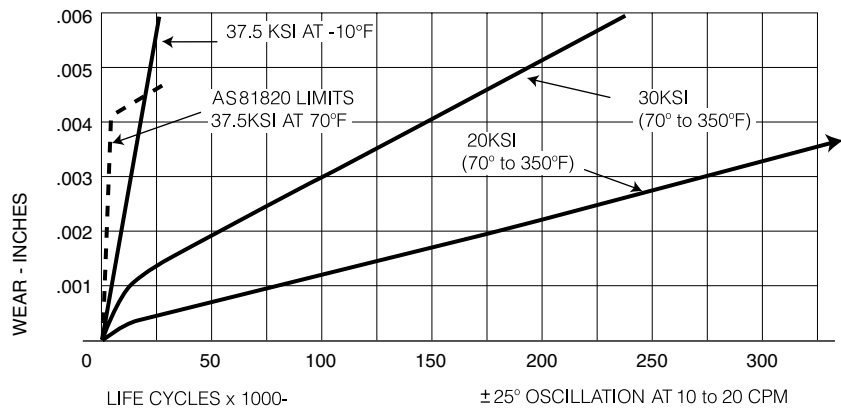

LINER TYPES:
X-1118
X-1276
X-1276F

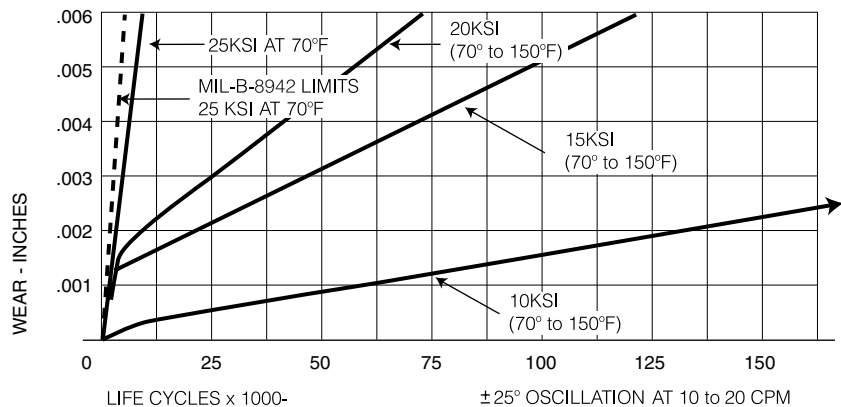

SELF-LUBRICATING LINER SYSTEMS

FIGURE 19 - PTFE BEARING EVALUATION CHART

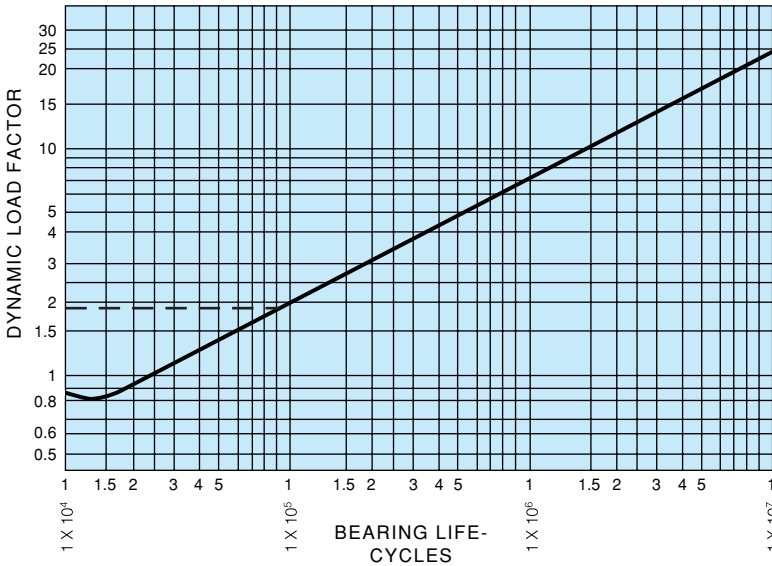

$T = \mu \times F \times R$
 where
 T = torque, In-lb
 μ = friction coefficient (Figure 17)
 F = load in pounds
 R = one-half of ball diameter for spherical bearings turning on ball; or one-half the bore diameter for plain journal bearings or spherical bearings turning on bore

FIGURE 20 - TORQUE FORMULA

TORQUE CALCULATION

The prediction of spherical bearing torque is more difficult than that of rolling element bearings. Friction coefficients of the sliding surfaces in these bearings vary depending on temperature and load. Torque at various loads is estimated by using the following formula:

INSTRUCTIONS FOR USE OF EVALUATION CHART

EXAMPLE 1

To select a PTFE-lined bearing to meet your need (for life other than 25,000 cycles):

- Multiply your expected radial dynamic load by the dynamic load factor corresponding to the required life cycles.
 Example: 5,000 lbs. (22,240 N), expected radial load; life requirement 100,000 cycles. Using the chart, 100,000 cycles corresponds to a dynamic load factor of 1.9. Multiplying 5,000 lbs. (22,240 N) by 1.9 = 9,500 lbs. (42,256 N), the equivalent dynamic load.
- Using the equivalent dynamic load of 9,500 lbs. (42,256 N), select any self-lubricated bearing having an oscillating load rating equal to or higher than this amount.

EXAMPLE 2

To determine the expected life cycles for a particular self-lubricated bearing:

- Divide oscillating load rating of bearing by your expected radial load to determine the dynamic load factor. Example 9,500 lbs. (42,256 N) ÷ 5,000 lbs. (22,240 N) = 1.9 dynamic load factor.
- Using 1.9 dynamic load factor, determine the bearing life—approximately 100,000 cycle.

PER-LOAD TORQUE

Rotational Breakaway Torque is the highest value attained just prior to ball movement. The ball should be hand rotated through several revolutions immediately before testing.

Rotational Torque is that value required to maintain 2 rpm rotation of the ball about its centerline.

Misalignment Torque is the value required to move the ball in a mode other than rotation.

All torque testing should be performed with the outer race restrained in such a manner as to minimize bearing distortion and the resultant effect on the torque reading obtained. Torque readings can vary appreciably as the result of incorrect clamping, presence of contaminants, excessive speeds and differences in atmospheric conditions. The need, as specified above, for hand rotating the ball through several revolutions prior to checking breakaway torque is extremely important. Because of pre-load between ball and race, the liner, under compression, slowly conforms to the microscopic surface irregularities of the ball. To initiate rotation after a period of time, all of the microscopic liner projections into the ball surface must be sheared off. Once this has been accomplished, the torque reverts back to its rated value.

GAGING LINED BORES

Conventional bore measuring equipment such as air gages, inside micrometers, etc. will often indicate an apparent oversize condition when used in measuring fabric lined journal bores. Texture and resiliency of the fabric liner as well as the contact pressure exerted by the gaging instruments all contribute to the probability of obtaining a false reading.

The most widely accepted method for inspecting lined journal bores is with the use of plug gages. The diameter of the “go” member should be 0.0008” (0.002 mm) below the minimum bore diameter specified and that of the “no-go” should be .00005” (0.0012mm) larger than the maximum bore diameter specified. The “go” member should enter freely or with light to moderate force. The “no-go” member should not enter with light force but entry under moderate to heavy force is acceptable. All edges of gage members should have a radius of .030” MIN (0.76mm), and surface finish of the gage should not exceed 8 RMS (0.2 µmRa) in order to prevent damage to the fabric when inspecting.

FACTORS AFFECTING THE SELECTION, PERFORMANCE AND EVALUATION OF PTFE-LINED SPHERICAL, ROD END JOURNAL BEARINGS

An answer to situations where the performance envelope cannot be covered by metal to metal bearings is to consider PTFE-lined bearings. Here, the lubricant configuration is such that it functions as the load carrying element of the bearing, as represented by the liner systems currently in use. PTFE bearings may be specified under all or some of the following situations:

1. Where lubrication is undesirable, difficult to perform, or impossible.
2. Where loads are high and angular movement is low. Under these circumstances, rolling element bearings fail rapidly.
3. Where space is limited. A PTFE-lined bearing in high load-low speed environments is usually much smaller in size than a rolling element bearing.
4. Where vibration is present. A PTFE-lined bearing is more likely to accept vibration than is a rolling element bearing.
5. Where temperature of the environment renders greasing unfeasible.
6. Where a joint must remain static for extended long periods of time before movement is initiated.
7. Where friction in a greased bearing would be so high as to render the joint area useless after a limited number of cycles or impose an unacceptable fatigue situation.
8. Where, in static joints, fretting is a problem.

While PTFE-lined bearings can do an excellent job in many areas, there have been areas of misapplication. Also, there exist some misunderstandings regarding life and failure as applied to hardware of this type. We may define some of these concepts as follows:

1. The PTFE-lined bearing starts life with a finite rotational pre-load torque or clearance.
2. This rotational pre-load torque always decreases with bearing usage and clearance always increases with usage.
3. A bearing may be said to have failed if the rotational pre-load torque drops below some specified value. This is always a systems application characteristic.
4. A bearing may be said to have failed when the clearance generated by wear exceeds some specified value. This, again, is always some specified systems characteristic.
5. A bearing may be said to have failed if the liner wears through enough to permit the ball to contact the race.
6. No bearing, including PTFE-lined bearings, will last forever. The "Lifetime" lubrication concept applies to the bearing alone, not to the end usage item.
7. The presence of liner debris on a bearing is not a definitive indication of failure.
8. PTFE-lined bearings tend to telegraph their impending failure by increased radial and axial play.

When evaluating the probable service life of a PTFE-lined bearing application, there are some factors that do not appear in the $PV = K$ relationship. Some considerations for a given application might include:

1. Surface sliding speed.
2. Maximum ambient temperature.
3. Size of the heat sink.
4. Acceptable friction levels.
5. Load per unit of area, or liner stress level.
6. Mode of load application; i.e., the duty cycle.
7. Service alignment accuracy, particularly with respect to sleeve and flanged bearings.
8. Surrounding atmosphere.
9. Tolerable wear rate.
10. Surface finish of the bearing mating shaft and the shaft material.

Cost is not included in the above list since it does not affect the serviceability of any bearing. Higher individual bearing costs may many times result in a more economical or lower priced finished assembly.

Other aspects of applying PTFE-lined bearings relate to many obscure factors. The airframe industry is a case in particular. They readily accept the L_{10} life concept in evaluating rolling element bearings but tend to reject it in lined bearings. In dealing with the troubleshooting relating to lined bearings at the user level, we may summarize most of them as follows:

1. Customers specify bearings to certain generalized specifications which may or may not reflect end usage requirements.
2. Customers very often have no idea, nor can they define what loads or loading situations the bearings may be subjected to during the design stage.
3. Continued upgrading of TBO performance on the part of users may not be consistent with established structural envelopes.
4. A marked difference exists between what is acceptable on military aircraft versus civil aircraft. Apparently specification writers overlook this aspect entirely.
5. Most customers and users do not realize that life in a lined bearing is limited. They accept this fact on clutches and brakes, but they apparently cannot see the similarity with respect to lined bearings.
6. No acceptable criteria have been established with respect to design or acceptable life for this type of bearing. Therefore it is almost impossible for a bearing supplier to initiate all-encompassing test programs.
7. Many bearings are removed and replaced because of detectable play between ball and race. Some bearings have been removed that still have specification pre-load torque. We must conclude that the potential service life of the bearing is not being used.
8. Confusion exists with regard to liner wear. The term "extruded liner" often noted on field UR's is not sufficiently definitive. Wear debris is normal to this type of bearing and must be differentiated from true liner failure.
9. The term "dynamic load rating" or "oscillating load rating" should not be used to select a bearing for an application. These ratings have no relationship to actual applications and relate to a qualification condition only.
10. Many line bearings are removed because of fretting between the bearing outer race and the adjacent structure. The use of metal-to-metal bearings will not eliminate this problem. This situation can be cured only by proper selection of materials and interface surface finishes.

GREASE AND DRY LUBRICANTS

ENGINEERING DATA

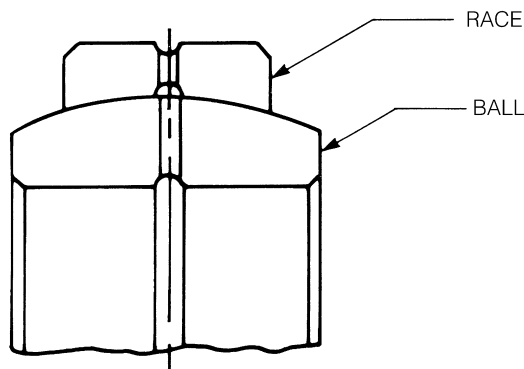

FIGURE 21

GREASE

When using a fluid (grease/oil) type lubricant, optimum lubrication is achieved when the moving member is supported by a hydrodynamic film. This hydrodynamic film is best generated under operating conditions of light loads and high speed rotation as characterized by typical ball bearing applications. The most common lubricated spherical bearing application, however, is typified by relatively high loads and slow oscillation, seldom by steady rotational movement.

In order to maximize distribution of the lubricant in spherical bearings, a radial clearance between the ball and race should be provided in the free state such that it is maintained after bearing installation. This clearance permits grease to flow between the ball and race surfaces. In addition, lube holes and interconnecting annular lube grooves should be provided as may be required. Annular lube grooves allow for 360° distribution of grease even when the bearing is relubricated under load.

Figure 21 illustrates a lubrication network which provides for lubricating both the ball/race and the ball/shaft (or pin) interfaces. Further, relubrication can be accomplished via the race housing or the ball shaft or pin. If relubrication is to be done via the race housing, and no lubrication is required in the ball bore, lube holes and I.D. lube groove in the ball may be omitted. Conversely, if relubrication is to be done via the shaft or pin, lube holes and O.D. groove in the race may be omitted.

Figure 22 shows a transverse lube groove configuration for use on medium to large size spherical bearings in critical applications where lubrication demands are more extreme. The transverse grooves are machined into the cylindrical race blank prior to swaging. These bearings are often bushed with copper alloy sleeves which in turn may incorporate transverse or equivalent lube groove patterns to provide for maximum possible lubrication.

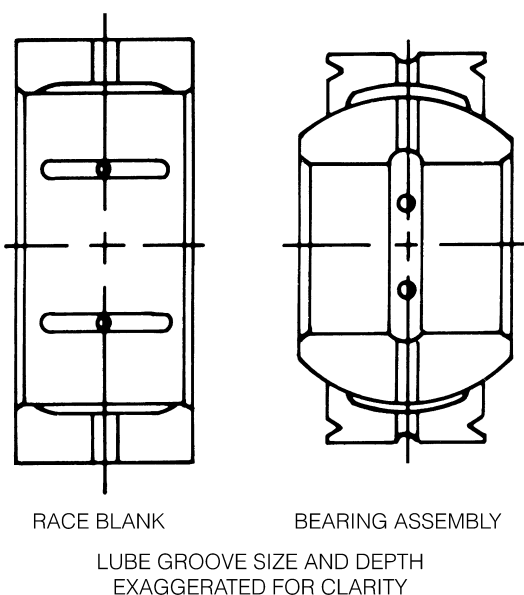

FIGURE 22

TABLE 4 - GREASE LUBRICANTS

TYPE	SPECIFICATION	COMPOSITION	TEMPERATURE RANGE	USE AND REMARKS
Grease, aircraft and instruments, gear, and actuator screw	MIL-PRF-23827	Lithium soap, ester oil, antirust and E.P. agents	-100° to + 250°F (-73° to + 121°C)	General purpose grease, Extreme pressure properties, good water resistance.
Grease, MoS ₂ for high and low temperatures	MIL-G-21164	Same as MIL-PRF-23827 except 5% MoS ₂ added	-100° to + 250°F (-73° to + 121°C)	Similar to MIL-PRF-23827 but has added MoS ₂ for extra E.P. properties and antiwear action under marginal lubrication conditions
Grease, aircraft, wide temperature range	MIL-PRF-81322	Synthetic oil and thickener	-65°F to + 350°F (-54°C to + 177°C)	Higher temperature range

TABLE 5 - DRY FILM LUBRICANTS

TYPE	SPECIFICATION	LUBRICANT	BINDER	TEMPERATURE RANGE	USE AND REMARKS
Solid film hear cured, corrosion inhibiting	MIL-PRF-46010	MoS ₂ (no graphite or powdered metals), and corrosion inhibitors	Organic resins	-90° to + 400°F (-68° to + 204°C)	Good wear Life and provide corrosion protection to substrate. Used for most bearing applications other than extreme temperature situations Must have phosphate coating pretreatment for effective use on steel
Solid film, extreme environment	MIL-PRF-81329	MoS ₂ and other solid lubricants	Inorganic binders	-300° to + 1200°F (-184° to + 648°C)	To be used in extreme environments, i.e., vacuum, liquid oxygen, high temperatures. Wear life not as good as resin-bonded types

Table 4 shows three most common grease lubricants used in NMB bearings and rod ends. Rod ends requiring relubrication are generally furnished with zerk type or flush type lube fittings except in those cases where relubrication is to be accomplished via the shaft or pin.

Proper, periodic relubrication of grease lubricated spherical bearings is essential to optimum bearing performance and long service life. Frequent relubrication reduces wear and friction, prevents fretting and galling, and minimize chemical corrosion.

DRY FILM

Dry film, also referred to as “solid film”, lubricants are generally used in applications which preclude the use of grease lubricated or PTFE lined bearings. In certain cases, however, they may be used as a “back-up” for grease lubricated bearings.

The majority of dry film lubricants consist of MoS₂ and small quantities of other materials, such as graphite or powdered metals. Coatings may be applied by spraying, brushing or dipping and are hardened by cure baking at temperatures which may vary from 200° to 1,000°F (93° to 538°C). Both organic resins and inorganic binders may be used.

Table 5 lists two common types of dry film lubricants used in aerospace bearings. In addition to these, however, NMB uses a wide variety of dry film compounds selected by our engineers to best meet the requirements of specific applications.

Dry film selection factors include:

- Temperature Range
- Compatibility with oils and greases
- Static load capacity
- Dynamic wear characteristics
- Exposure to extreme environments, i.e., vacuum LOX, radiation, etc.

LOCKING DEVICES, KEYS AND KEYWAYS

ENGINEERING DATA

Keys are represented here are metallic locking devices which, when assembled into keyways and keyslots, prevent relative motion between mating components of bearing linkage assemblies.

NMB does not supply keys, nuts or lock wire as separate items. These items are readily available from other sources.

Keyways and keyslot are optional. To specify, add suffix "W" to NMB catalog rod end part number.

NAS 513 KEY

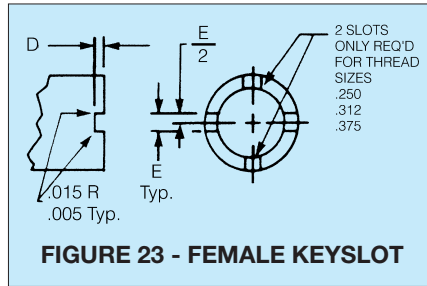
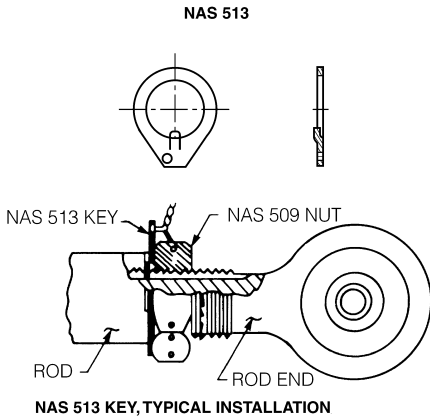

FIGURE 23 - FEMALE KEYSLOT

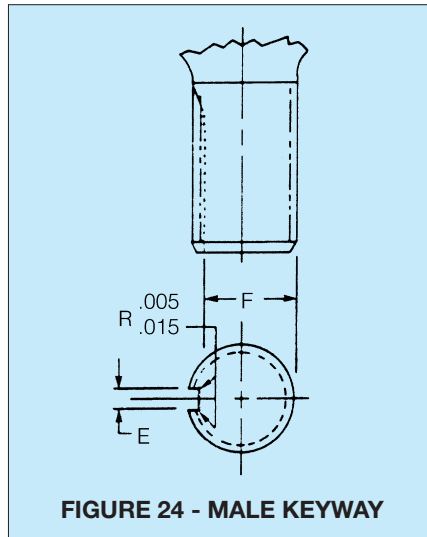

FIGURE 24 - MALE KEYWAY

Thread Size	D	E	F
②	+.005 -.000	+.005 -.000	+.000 -.005
.2500	.056	.062	.201
.3125	.056	.062	.260
.3750	.056	.093	.311
.4375	.069	.093	.370
.5000	.069	.093	.436
.5625	.077	.125	.478
.6250	.077	.125	.541
.7500	.077	.125	.663
.8750	.086	.156	.777
1.0000	.094	.156	.900
1.1250	.094	.187	1.010
1.2500	.116	.187	1.136
1.3750	.116	.250	1.236
1.5000	.116	.250	1.361
1.6250	.129	.250	1.477
1.7500	.129	.312	1.589
1.8750	.129	.312	1.714
2.0000	.129	.312	1.839
2.1250	.129	.312	1.955
2.2500	.129	.312	2.080

NOTES:

- NAS 513 keys are used on MIL-B-81935 size -10 through -16 and MS21151 and MS21153 rod ends when optioned. The keyways and keyslots used in conjunction with these keys are shown in Fig. 23 and Fig. 24.
- NAS 513 keys are available for thread sizes 1/4 through 2-1/4 inches.

NAS 1193 KEY

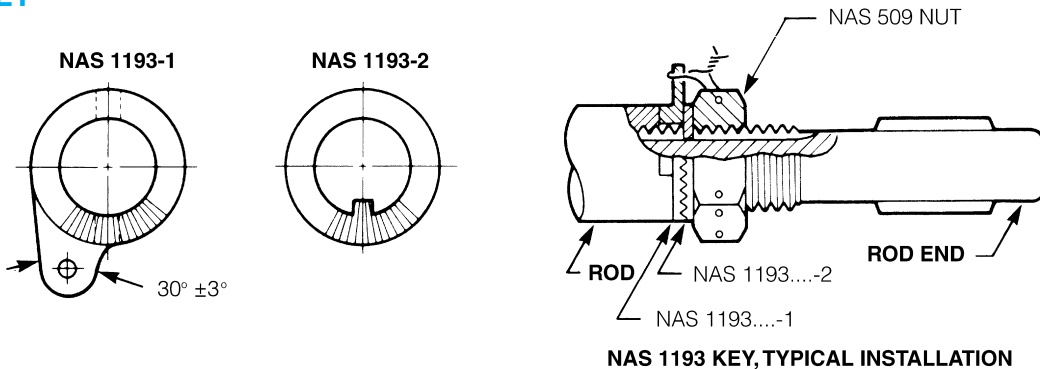

NAS 1193 KEY, TYPICAL INSTALLATION

NOTES:

- NAS 1193 keys are for positive indexing. They are used in applications in which a fine adjustment is required, within .001 inches.
- These keys can be used in conjunction with NAS 513, NAS 559 and AS81935/3 keyways or keyslots are available for thread sizes 1/4 through 2-1/4 inches.

LOCKING DEVICES, KEYS AND KEYWAYS

NAS 559 TYPE A KEY

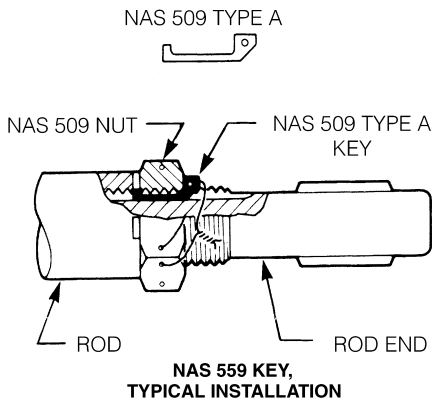

NOTES:

- ① The keyways and keyslots used in conjunction with these keys are shown in Fig. 25 and Fig. 26. The NAS 559 keys are available for thread sizes 1/4 through 2-1/4 inches.
- ② Keyway flat may vary from standard on smaller size rod ends but shall extend at least beyond minimum thread length in all cases.

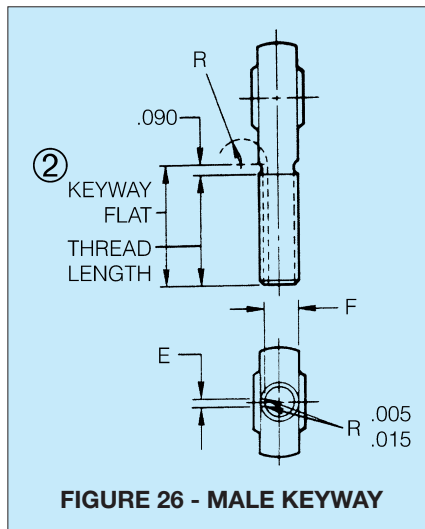
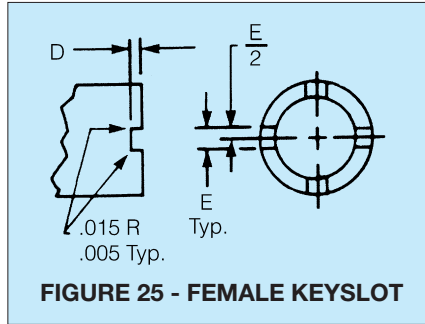

Thread Size	D	E	F	R
①	+0.005 -0.000	+0.005 -0.000	+0.000 -0.005	±0.010
.2500	.056	.062	.201	.255
.3125	.056	.062	.260	.255
.3750	.056	.093	.311	.255
.4375	.069	.093	.370	.255
.5000	.069	.093	.436	.255
.5625	.077	.125	.478	.255
.6250	.077	.125	.541	.255
.7500	.077	.125	.663	.255
.8750	.086	.156	.777	.318
1.0000	.094	.156	.900	.318
1.1250	.094	.187	1.010	.382
1.2500	.116	.187	1.136	.382
1.3750	.116	.250	1.236	.445
1.5000	.116	.250	1.361	.445
1.6250	.129	.250	1.477	.445
1.7500	.129	.312	1.589	.508
1.8750	.129	.312	1.714	.508
2.0000	.129	.312	1.839	.508
2.1250	.129	.312	1.955	.508
2.2500	.129	.312	1.080	.508

AS81935/3 key

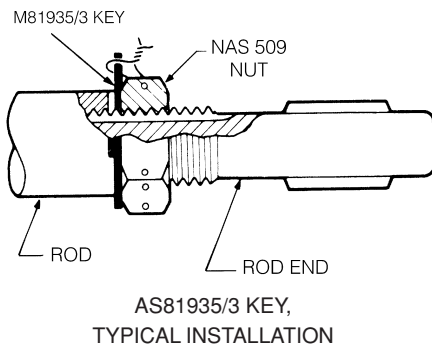
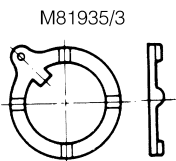

NOTES:

1. AS81935/3 keys are used on AS81935 sizes -3 through -8 when optional. The keyways and keyslots used in conjunction with these keys are shown in Fig. 27 and Fig. 28.
- ② AS81935/3 keys are available for thread sizes 1/4 through 1/2 inches.

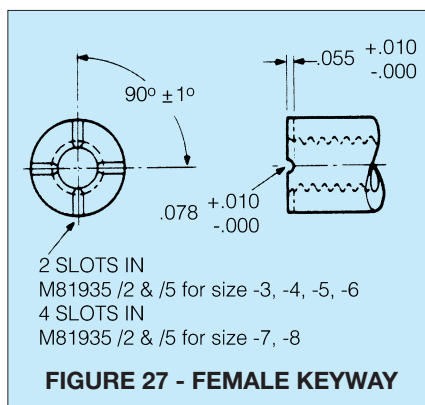

Thread Size (Male)	E	F
②	+0.005 -0.000	+0.000 -0.005
.2500-28UNJF-3	.062	.207
.3125-24UNJF-3	.062	.268
.3750-28UNJF-3	.093	.319
.4375-20UNJF-3	.093	.383
.5000-20UNJF-3	.093	.445

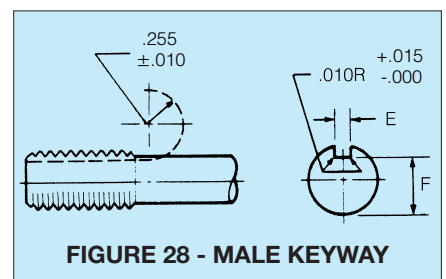

BEARING INSTALLATION AND RETENTION

ENGINEERING DATA

GENERAL

A bearing in the free state is not a functioning bearing. Its performance begins only after it has been installed into its end assembly, and the methods, fits and forces applied in installation will often determine its success or failure in service.

A surprising percentage of early bearing failures can be traced directly to improper mounting conditions. Some examples of frequently occurring installation errors are:

(1) excessive interference fit between housing bore and bearing O.D. (2) improperly designed staking tools. (3) excessive staking forces applied.

The following pages are offered not as a comprehensive guide to answer all questions regarding fits, installation, retention, etc., but rather to point out to the bearing user certain areas that require attention and consideration if the installation is to provide for optimum bearing performance and life.

HOUSINGS

The housing into which the bearing is to be mounted should be designed to ensure the structural integrity and dynamic performance capability of the bearing. NMB offers the following housing design recommendations:

1. Bearing-to-housing fit: (See table 7).
2. Bore finish : 32 RMS (0.8 μ mRa)
3. Roundness within the bore diametrical tolerance.
4. Bore perpendicular to housing faces within .002" (0.05 mm).
5. Housing width : uniform within .005" (0.13 mm) to ensure staking integrity.
6. Maximum edge breaks of .005" (0.13 mm) when housing is to be staked over bearing.
7. Chamber sizes as calculated per figure 29 formula for V-groove staking retention.
8. Provide for plating or other surface treatments (as may be required) if housing and bearing are of dissimilar metals. (See table 6).

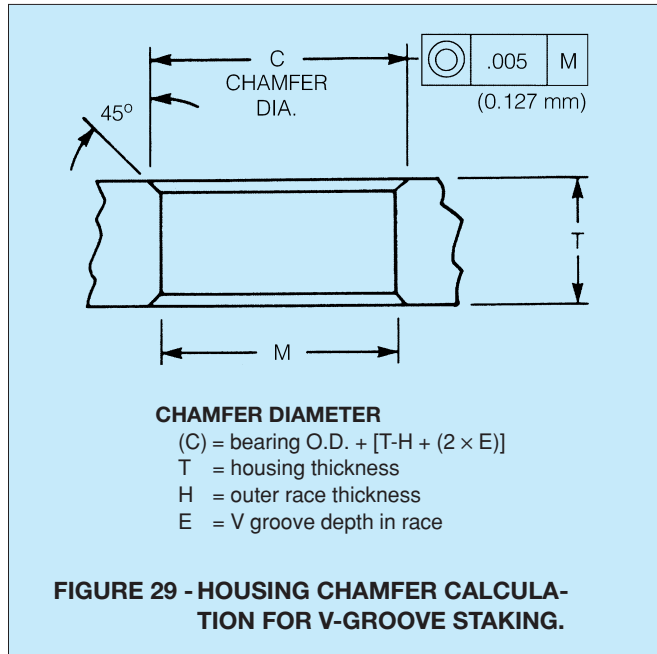

Another material consideration, in addition to dissimilar metals, is that of differing coefficients of thermal expansion between the bearing and housing materials. When the bearing is to be operating over a broad temperature range, and the mating bearing and housing have different coefficients of expansion, special adjustments may be required in the bearing to housing fit to prevent either excessive looseness or excessive torque at temperature extremes.

BEARING INSTALLATION AND RETENTION

TABLE 6 - TREATMENTS TO PREVENT GALVANIC CORROSION OF DISSIMILAR METALS

Bearing Material (Bore and O.D. Surface)	Housing or Shaft Material				
	Aluminum Alloys	Low Alloy Steel	Titanium	Corrosion Resistant Steel	Superalloys
Aluminum alloys	A	A,C	A	A,C	A,C
Bronze and brass	A,C	C	S	S	S
Bronze and brass, cadmium plated	A	C	X	S	S
52100 and low alloy steels	A,C	C	X	C	C
440C stainless steel	A,C	C	S	S	S
440C with wet primer	A	C	S	S	S
Corrosion resistant steels, 300 series, 17-4PH, 15-5PH, PH13-8Mo, etc	A,C	C	S	S	S
Superalloys	A,C	C	S	S	S

X = Incompatible

A = Anodize aluminum per MIL-A-8625, Type II, or Alodine per MIL-C-5541

C = Cadmium plate per AMS-QQ-P-416, Type I, Class 2

S = Satisfactory for use with no surface treatment required.

TABLE 7 - HOUSING BORE TOLERANCES FOR METAL TO METAL AND PTFE LINED BEARINGS

BEARING				HOUSING BORE			
TYPE	STYLE	O.D.		Tolerances		Fit-up	
		inch	mm	inch	mm	inch	mm
METAL TO METAL	Sphericals	Up to 1.750	Up to 44.45	+0.000 -0.0005	+0.000 -0.013	Line to Line to .0010 tight	Line to Line to 0.025 tight
		1.750 and over	44.45 and over	+0.000 -0.0008	+0.000 -0.020	Line to Line to .0013 tight	Line to Line to 0.033 tight
PTFE LINED	Sphericals	All	All	+0.0005 -0.0000	+0.013 -0.000	Line to Line to .0010 loose	Line to Line to 0.025 loose
	Plain and Flanged Journal (Sleeve) Bearings	Up to 1.000	Up to 25.40	-0.0007 -0.0012	-0.018 -0.030	.0002 to .0012 tight	0.005 to 0.030 tight
		1.000 and over	25.40 and over	-0.0010 -0.0015	-0.025 -0.038	.0005 to .0015 tight	0.013 to 0.038 tight

BEARING INSTALLATION AND RETENTION

ENGINEERING DATA

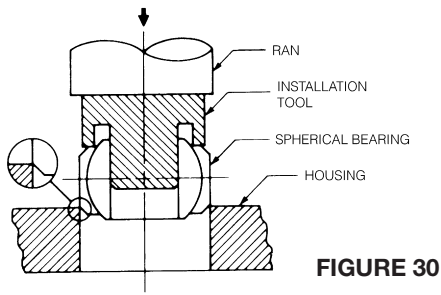

FIGURE 30

SPHERICAL BEARING INSTALLATION

Use of an arbor press or hydraulic press is recommended. Under no circumstances should a hammer or any other type of shock including impact method be used. A suitable installation tool (as shown in Figure 30) is advised. A guide pin aligns the ball in a 90° position, but all force is applied to the outer race only. A lead chamfer or radius on either the bearing or housing is essential.

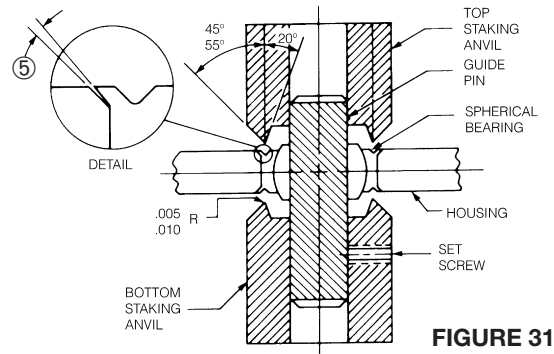

FIGURE 31

V-GROOVE RETENTION (V-GROOVE SERIES)

For bearings with race staking grooves, a double anvil staking method as shown in Figure 31 is recommended. This method is best performed on a hydraulic or pneumatic press.

STAKING PROCEDURE:

1. Install bearing into housing per Figure 30 and position it symmetrical about housing centerline within .005" (0.127 mm).
2. Mount bearing and top anvil over bottom anvil guide pin as shown in Figure 31.
3. A trial assembly should be made for each new bearing lot to determine the staking force necessary to meet the axial retention load required. Excessive force should be avoided since this may result in bearing distortion and seriously impair bearing function and life. (See Staking Force, Page 21.)
4. Apply the staking force established by trial assembly, rotate assembly 90° and re-apply force. Repeat operation through a minimum of 3 rotations to ensure 360° uniformity of lip swaging.
5. After staking, a slight gap may exist between race lip and housing chamfer as shown in detail in Figure 31. This gap should not be a cause for rejection providing bearing meets the thrust load specified.

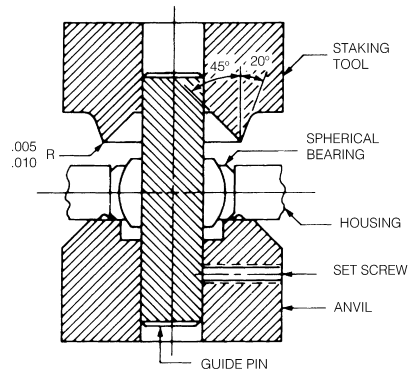

FIGURE 32

HOUSING STAKE RETENTION (CHAMFERED BEARING SERIES)

Retention of chamfered bearings may be accomplished by many methods and may vary according to housing configuration, material, hardness and the axial thrust load required. When axial loads are light to moderate, a housing ring staking tool as shown in Figure 32 may be used. The bearing and housing are supported by an anvil while the annular staking tool is forced into one side of the housing flaring a small amount of the housing material over the race chamfer. The opposite side of the housing is then staked in the same manner. When this method is used, the housing crosshole edges should be sharp to a .005" (0.13 mm) maximum radius or chamfer. As with the V-groove staking, excessive staking forces should be avoided in order to prevent deformation of the spherical bearing.

LINED JOURNAL BEARING INSTALLATION

The same general procedure as outlined for spherical bearings should be followed. (See Figure 30). In the case of fabric lined bores, however, it is mandatory that both the insertion tool guide pin and the mating shaft have ends free of both burrs and sharp edges. A .030" (0.76 mm) blended radius or 15° lead (as shown in Figure 34) is recommended, since it is virtually impossible to install a sharp edged shaft without inflicting some damage to the fabric liner. For maximum support of the fabric lined bore, the effective length of the insertion tool guide pin should exceed the journal bearing length.

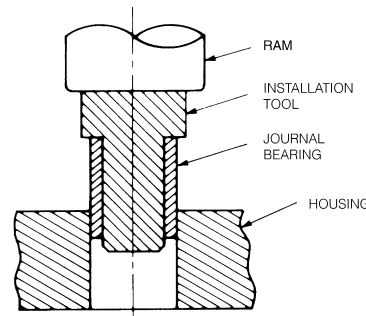

FIGURE 33

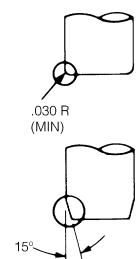

FIGURE 34

BEARING INSTALLATION AND RETENTION

ENGINEERING DATA

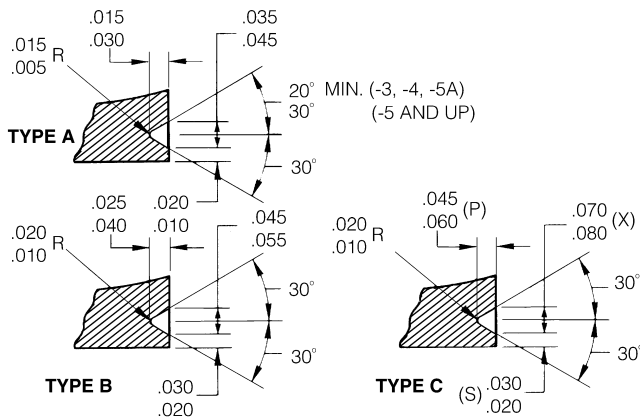

FIGURE 35 - STANDARD V-GROOVE TYPES & SIZES

TABLE 8 - V-GROOVE STAKING FORCE

GROOVE TYPE*	A	B	C
CONSTANT (lbs)	7,700	12,000	17,700
CONSTANT [N]	34,250	53,376	78,730
*SEE FIGURE 35 FOR GROOVE SIZES			

STAKING FORCE

The force required to stake V-groove bearing is approximately equal to the product of the O.D. and a constant for each groove size. For example, a 1.500" (38.10 mm) O.D. bearing having a "B" size groove should require a staking force of approximately 18,000 lbs (80064 N). Constants shown in Table 8 are based on outer race material having an ultimate tensile strength of 140,000 psi (984.6 N/mm²). Staking force constants for other materials are proportional to the ultimate tensile of those materials as compared to 140,000 psi (984.6 N/mm²). Staking forces derived by this formula should be used as a reference guide only to establish a starting point. Please refer to STAKING PROCEDURE steps outlined on page 22.

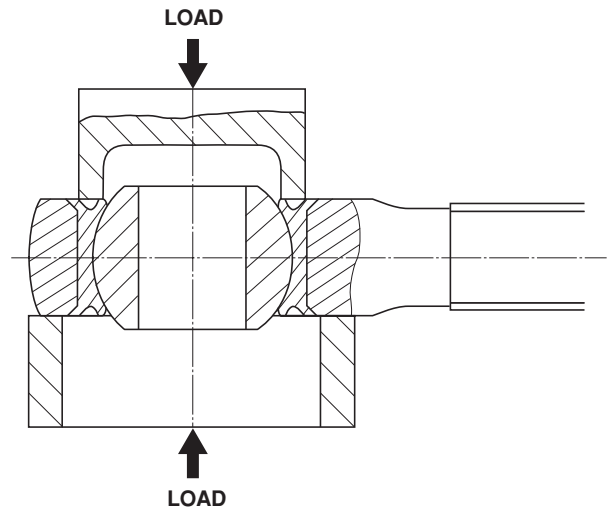

FIGURE 36 - STAKING BEARING PROOF LOAD TEST METHOD

PROOF LOADING

Figure 36 shows the test set-up specified in AS81935 for axial static proof load testing of rod ends with V-groove staked inserts. This is the generally accepted method used by spherical bearing and airframe manufactures for checking axial retention of the stake. The rod end assembly is mounted on a rigid ring which clears the flared O.D. of the insert and supports the rod end body only. The axial proof load is applied to the ball face, the bearing is then reversed 180° and the axial load is repeated on the opposite side.

The approximate proof load can be estimated from TABLE 9.

TABLE 9 - THRUST LOADS BASED ON FIGURE 35 GROOVE TYPES AND MATERIALS SPECIFIED

V-Groove Type	X		P		S		Axial Static Proof Load lbs (N)	
	(inch)	(mm)	(inch)	(mm)	(inch)	(mm)	Steel Race (30 ~ 35 HRC)	Al-Bz Race
	+0.000 -0.010	+0.00 -0.25	+0.000 -0.015	+0.000 -0.038	+0.000 -0.010	+0.00 -0.25		
A	.045	1.14	.030	0.76	.020	0.51	1,700 × D" (298 × D mm)	1,100 × D" (193 × D mm)
B	.055	1.40	.040	1.02	.030	0.76	2,090 × D" (367 × D mm)	1,360 × D" (239 × D mm)
C	.080	2.03	.060	1.52	.030	0.76	2,340 × D" (411 × D mm)	1,520 × D" (267 × D mm)

LOAD RATINGS AND MISALIGNMENT CAPABILITIES

ENGINEERING DATA

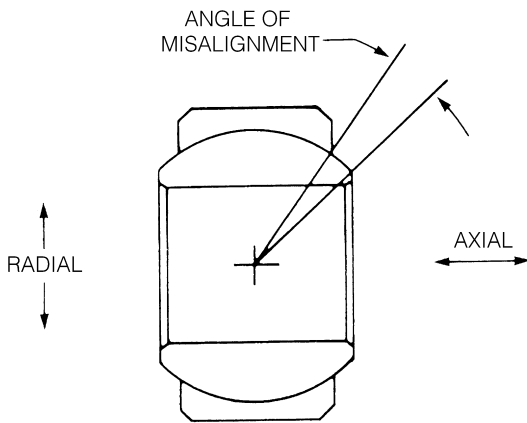

FIGURE 37

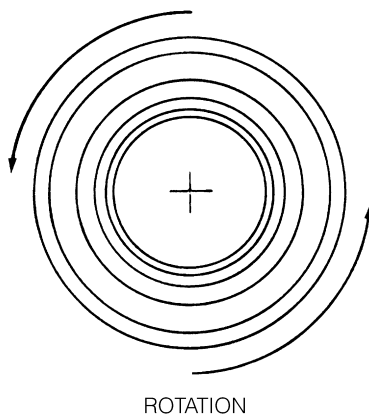

FIGURE 38

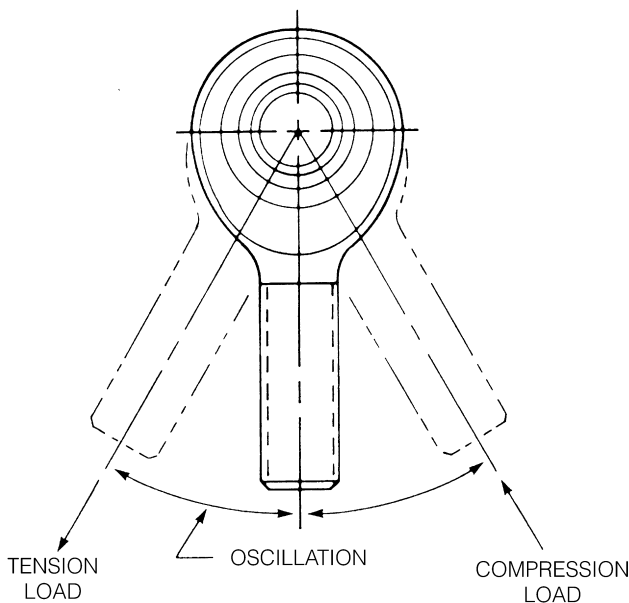

FIGURE 39

DEFINITIONS FOR ROD END AND SPHERICAL BEARING TERMINOLOGY

Radial Load

A load applied normally to the bearing bore axis. (See Figure 37).

Axial Load

A load applied along the bearing bore axis. (See Figure 37).

Static Load

Is the load to be supported while the bearing is stationary.

Dynamic Load

Is the load to be supported while the bearing is moving.

Static Radial Limit Load *

That static load required to produce a specified permanent set in the bearing. It will vary for a given size as a function of configuration. It may also be pin limited or, may be limited as a function of body restraints as in the case of a rod end bearing. Structurally, it is the maximum load which the bearing can see once in its application without impairing its performance.

Static Radial Ultimate Load *

That load which can be applied to a bearing without fracturing the ball, race or rod end eye. The ultimate load rating is usually, but not always, 1.5 times (1.25 times for rod end) the limit load.

Static Axial Limit Load

That load which can be applied to a bearing to produce a specified permanent set in the bearing structure. Structurally, it is the maximum load which the bearing can see once in its application without impairing its performance.

Static Axial Ultimate Load

That load which can be applied to a bearing without separating the ball from the race. The ultimate load rating is usually, but not always, 1.5 times the limit load.

Axial Static Proof Load

That axial load which can be applied to a mounted spherical bearing without pushout of the bearing from the rodend body.

Fatigue Load

That load which can be applied a rod end bearing withstanding a minimum of 50,000 cycles of alternate load. The loading shall be tension-tension with 100% of fatigue load and 10% of fatigue load.

* LOAD CAPACITY FOR NECK BALL TYPE BEARINGS

Load figures given on the Table of Dimension are based on outer race load capacity.

Pin deformation due to fit, hardness and so on may result in crack of ball (inner race).

LOAD RATINGS AND MISALIGNMENT CAPABILITIES

ENGINEERING DATA

OSCILLATING RADIAL LOAD OR DYNAMIC LOAD

The uni-directional load producing a specified maximum amount of wear when the bearing is oscillated at a specified frequency and amplitude. This rating is usually applied to self-lubricating bearings only. The dynamic capability of metal to metal bearings depends upon the degree and frequency of grease lubrication, and that of dry film lubricated bearings upon the characteristics of the specific dry film lubricant applied.

RADIAL PLAY

Radial play (or radial clearance) is the total movement between the ball and the race in both radial directions less shaft clearance (when applicable). US military specifications have established the gaging load at 5.5lbs. (24.5 N) and this is now considered as the industry standard (See Figure 42). Unless otherwise specified, the industry wide standard for metal-to-metal spherical bearing and rod end radial clearance is "free-running to .002" (51 μm) MAX" Radial play is sometimes referred to as "Diametral play". The two terms are synonymous.

AXIAL PLAY

Axial play (or axial clearance) is the total movement between the ball and the race in both axial directions. The gaging load at again 5.5lbs. (24.5 N). Axial play is a resultant, being a function of radial play, of ball diameter and race width. The ratio between radial and axial play varies with bearing geometry.

TORQUE

(See Self-Lubricating Liner Systems Section).



TORQUE METER

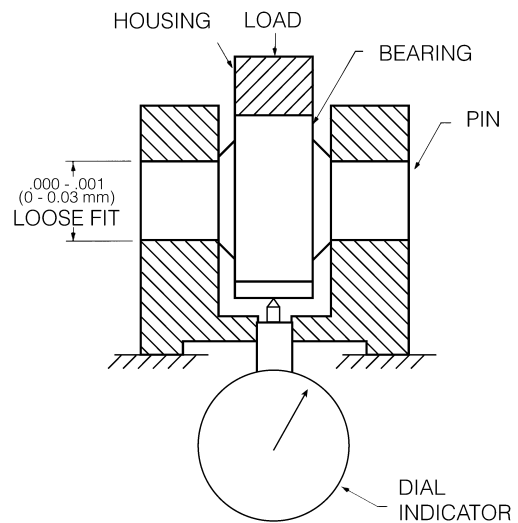

FIGURE 40 - RADIAL TEST FIXTURE

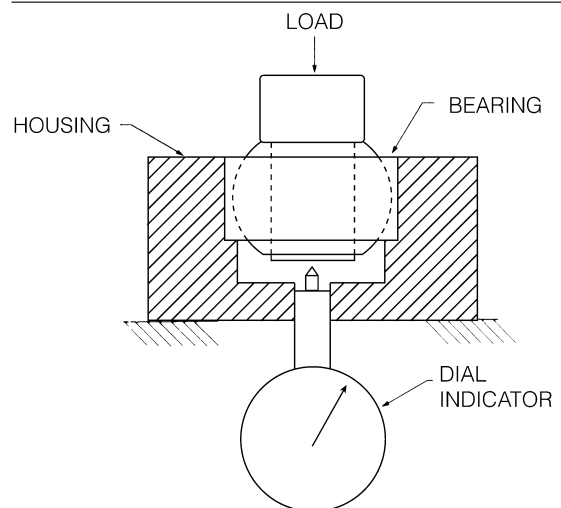

FIGURE 41 - AXIAL TEST FIXTURE

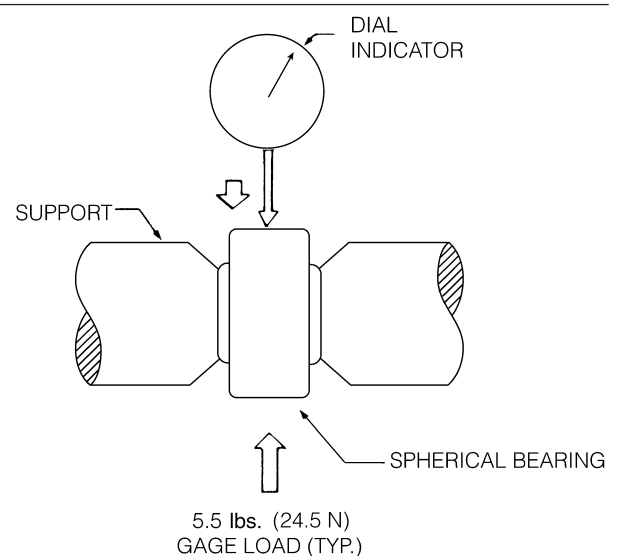

FIGURE 42 - METHOD OF MEASURING RADIAL PLAY

LOAD RATINGS AND MISALIGNMENT CAPABILITIES

ENGINEERING DATA

LOAD RATINGS

The load rating of a bearing is determined by the dimensions and strength of its weakest component. External factors, such as mounting components, pins, bolts, and housings are not considered part of a bearing when load ratings are investigated but should be considered separately.

SPHERICAL BEARING LOAD RATINGS

The weakest part, or load-limiting area, of a spherical bearings is its race. For this reason, formulas have been developed that use the race to calculate static load ratings based on size and material strength. The static load rating formulas for self-lubricating and metal-to-metal spherical bearings are shown in figure 43 and 44. These formulas will yield approximate ratings, which should be used as ballpark numbers for bearing design.

The allowable radial stress figures given in the tables were determined from the ultimate tensile strength specifications for various race materials. Allowable axial stress figures were derived from material yield strengths.

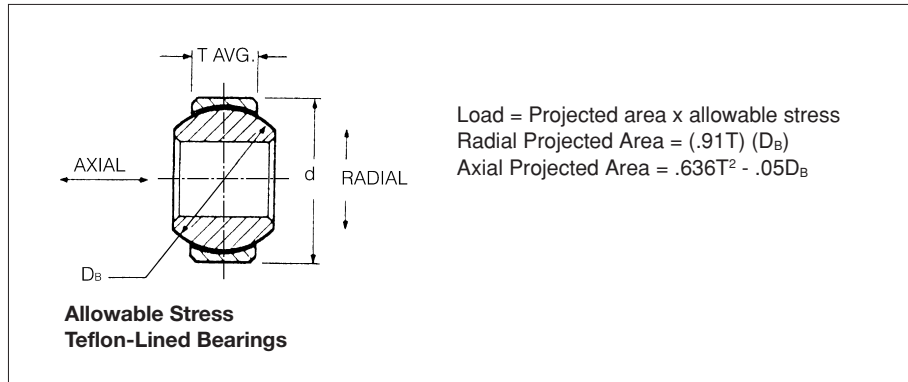

FIGURE 43 - Static load rating formulas for self-lubricating spherical bearings.

Allowable Stress Teflon X-1820 Lined Bearings (psi)

Race Material	Radial		Axial	
	Ultimate	Limit	Ultimate	Limit
17-4PH, 28 HRC MIN	112,500 (775 N/mm ²)	75,000 (517 N/mm ²)	67,500 (465 N/mm ²)	45,000 (310 N/mm ²)
ALUM 2024-T351	60,000 (413 N/mm ²)	40,000 (276 N/mm ²)	36,000 (248 N/mm ²)	24,000 (164 N/mm ²)

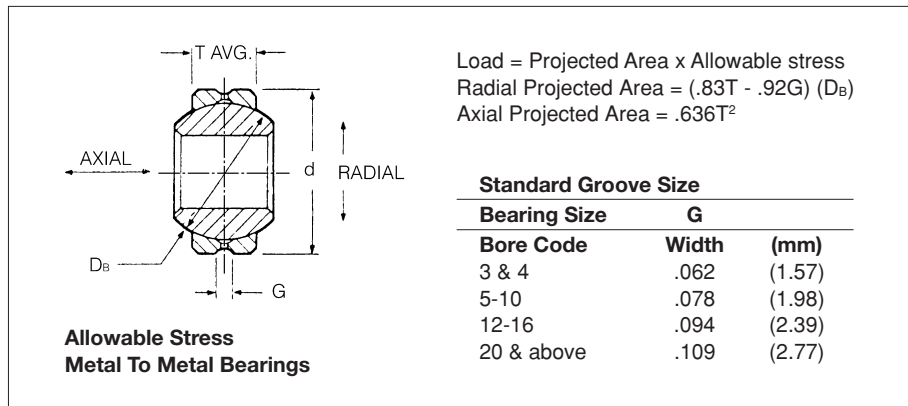

FIGURE 44 - Static load rating formulas for metal to metal spherical bearings.

Allowable Stress Metal To Metal Bearings (psi)

Race Material	Radial		Axial	
	Ultimate	Limit	Ultimate	Limit
17-4PH, 32-36 HRC	150,000 (1034 N/mm ²)	100,000 (689 N/mm ²)	125,000 (861 N/mm ²)	83,000 (572 N/mm ²)
4130 32-36 HRC	150,000 (1034 N/mm ²)	100,000 (689 N/mm ²)	125,000 (861 N/mm ²)	83,000 (572 N/mm ²)
A286 (AMS 5737)	140,000 (965 N/mm ²)	93,000 (641 N/mm ²)	95,000 (655 N/mm ²)	63,000 (434 N/mm ²)
C62300 Al-Bz (ASTM B150)	75,000 (517 N/mm ²)	50,000 (345 N/mm ²)	45,000 (310 N/mm ²)	30,000 (207 N/mm ²)

LOAD RATINGS AND MISALIGNMENT CAPABILITIES

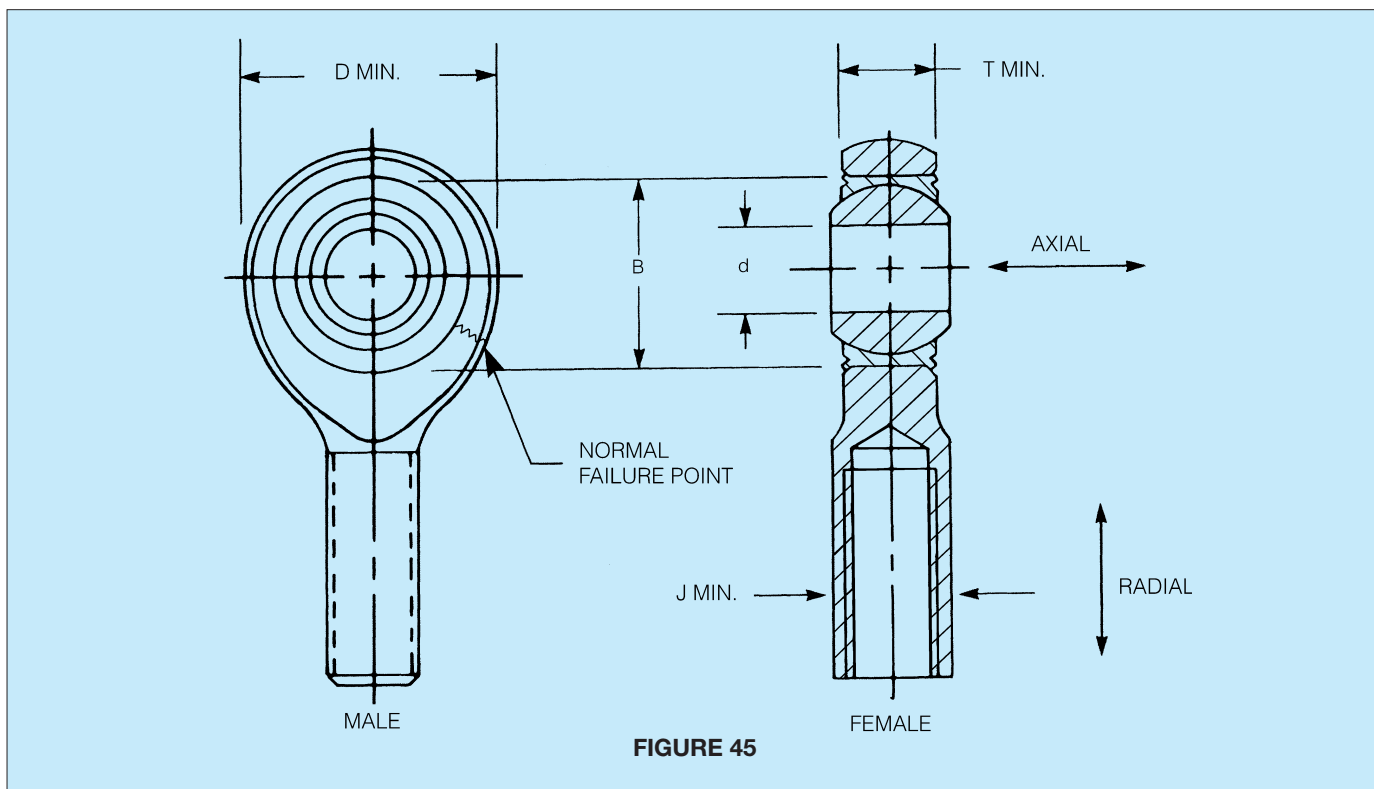

FIGURE 45

Rod end bearing load ratings can be generated only after carefully determining the load restrictions that each element of the rod end bearing imposes on the entire unit. In order to generate a frame of reference, consider the rod end bearing as a clock face, with the shank pointing down to the 6 o'clock position. The limiting factors in rating a rod end bearing are as follows:

1. The double shear capability of the bolt passing through the ball bore.
2. The bearing capability, a function of race material or self-lubricating liner system.
3. The rod end eye or hoop tension stress in the 3 o'clock-9 o'clock position.
4. The shank stress area, as function of male or female rod end configuration.
5. The stress in the transition area between the threaded shank transition diameter and the rod end eye or hoop.

Most rod ends will fail under tension loading in about the 4 o'clock-8 o'clock portion of the eye or hoop. The hoop stress area (HSA) can be found as follows:

$$HSA = .008762 \times D^2 \times \sin^{-1} \frac{T}{D} + \frac{T}{2} \times \sqrt{D^2 - T^2} - B \times T$$

The shank stress area (SSA) is a function of being either male or female, as follows:

For the male:

$$SSA = (\text{minor thread diameter})^2 / 4$$

For the female:

$$SSA = [J^2 - (\text{major thread diameter})^2] / 4$$

Pin shear stress (PSS) for a load "F" is as follows:

$$PSS = \frac{2F}{d^2}$$

The axial load capability of a rod end is a function of the following:

1. The retention method used to mount the bearing in the rod end eye.
2. The axial load capability of the bearing element.
3. The bending moment, if any, placed on the rod end.
4. The race half width $\frac{T}{2}$ of the bearing element.

This is a function of the axial projected area (APA) of the bearing.

$$APA = \left(\frac{T}{2}\right)^2$$

LOAD RATINGS AND MISALIGNMENT CAPABILITIES

ENGINEERING DATA

FORMULA FOR DETERMINING MISALIGNMENT OF ROD END & SPHERICAL BEARINGS

FIGURE 46

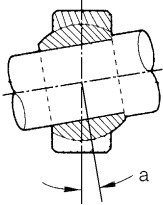

$$a = \sin^{-1} \frac{W}{E} - \sin^{-1} \frac{T}{E}$$

STANDARD METHOD

MOST STANDARD ROD END & SPHERICAL BEARING MISALIGNMENT ANGLES SPECIFIED IN NMB CATALOGS ARE BASED ON THIS METHOD.

FIGURE 47

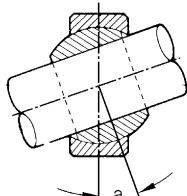

$$a = \cos^{-1} \frac{R}{E} - \sin^{-1} \frac{T}{E}$$

DESIGN REFERENCE

THIS METHOD MAY BE USED AS DESIGN REFERENCE FOR INSTALLATION PURPOSES, BUT SHOULD NOT BE USED AS A FUNCTIONING MISALIGNMENT UNDER LOAD.

FIGURE 48

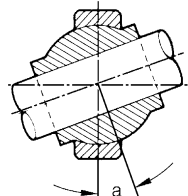

$$a = \cos^{-1} \frac{S}{E} - \sin^{-1} \frac{T}{E}$$

HIGH MISALIGNMENT SERIES METHOD (NECK BALL ONLY)

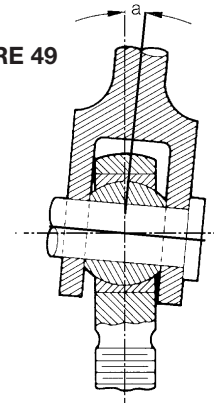

FIGURE 49

$$a = \sin^{-1} \frac{W}{D} - \sin^{-1} \frac{T}{D}$$

ROD END CLEVIS MISALIGNMENT

The misalignment angle of a rod end or spherical bearing refers to the angle between the ball centerline and the outer member centerline when the ball is misaligned to the extreme position allowed by the clevis or shaft design, as applicable.

NOTE:

SINCE ANGLE "a" APPLIES EQUALLY ON BOTH SIDES OF THE CENTERLINE, IT FOLLOWS THAT TOTAL MISALIGNMENT OF THE BEARING IS DOUBLE THE VALUE OBTAINED FOR "a".

Figure 46 through 49 illustrate varying types of bearing misalignment and a formula for calculating each.

WHERE;

- a = Angle of Misalignment
- B = Bore of Ball
- D = Head Diameter (Rod End)
- E = Ball spherical Diameter
- S = Shoulder Diameter (Neck Ball)
- T = Housing (Race) Width
- W = Width of Ball

HOW NMB SPECIFIES CATALOG BEARING AND ROD END MISALIGNMENT

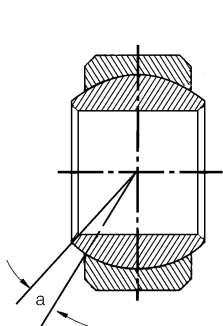

FIGURE 50

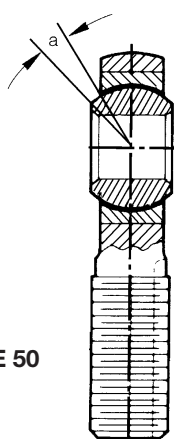
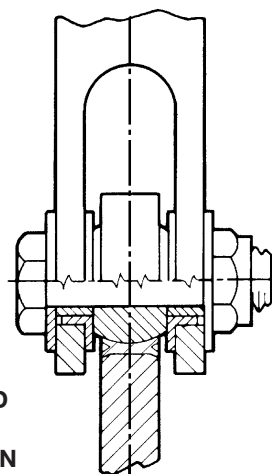

FIGURE 51 - TYPICAL ROD END/CLEVIS INSTALLATION



in the same manner, but are calculated per Figure 48 formula.

NMB prefers not to use rod end clevis misalignment for the following reason. The rod end clevis misalignment formula presupposes a clevis configuration as shown in Figure 49 in which the clevis slot and ball faces are of equal width and in direct contact. In aircraft applications the configuration shown in Figure 51 is more typical than that of Figure 49. As pictured in Figure 51, the clevis slot is wider than the ball to permit installation of flanged bushings and/or spacers. This results in a higher but more variable misalignment capability and the angle of misalignment becomes a function of the user's bushing flange or spacer diameter instead of the fixed rod end head diameter.

Figure 51 illustrates how misalignment angles for standard ball spherical bearings and rod ends are represented in NMB catalog. The misalignment angle is calculated per Figure 46 formula. Neck ball (high misalignment) bearings and rod ends are represented

LOAD RATINGS AND MISALIGNMENT CAPABILITIES

ENGINEERING DATA

PV Factor

While not a type of loading, the PV factor is very useful in comparing and predicting test results on high speed-low load applications such as helicopter conditions.

PV is the product of the stress (psi or N/mm²) and the velocity (fpm or m/min) applied to a bearing. Caution must be advised when considering extreme values of psi (N/mm²) and fpm (m/min). The extreme must be considered individually as well as together.

Because the PV factor is derived from the geometry and operating conditions of a bearing, it serves as a common denominator in comparing or predicting test results.

The formula for determining the PV value for a spherical bearing is as follows:

$$PV = (x) (\text{cpm}) (D_B) (\text{psi}) (.00073)$$

Where:

x = Total angular travel in degrees per cycle

cpm = cycles per minute

DB = ball diameter

psi = bearing stress (use N/mm² for metric)

Dynamic Oscillating Radial Load

The dynamic oscillating radial load ratings given in this catalog for HT, WHT, HTL and WHTL series self-lubricating spherical bearings are based on testing in accordance with AS81820. For conditions other than those specified by AS81820 for catalog part number, use the formula given below to predict wear.

$$W = \frac{C}{\left(\frac{L_R^{2.13}}{L_A}\right) \times \frac{(100)}{X} \times 25,000} \times .0045 \quad (.114\text{mm})$$

Where:

W = calculated wear

C = actual total cycles

L_R = rated dynamic load (see product tables)

L_A = actual dynamic load

x = total angular travel in degrees per cycle

For special self-lubricating bearings that do not appear in this catalog, determine the radial projected area and multiply by 39,900 psi (275 N/mm²). This determines L_R, and the formula can then be used to predict wear.

LOAD DEFINITIONS (Rod End Bearings, Anti-Friction Bearings)

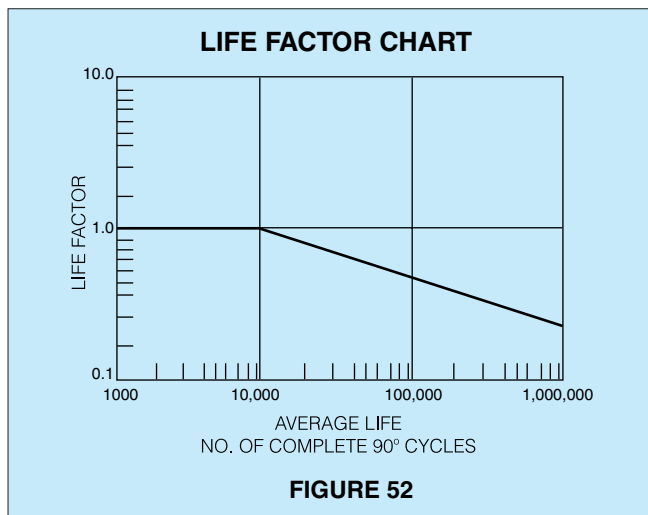

RADIAL LOAD - A load applied normal to the bearing bore axis.

AXIAL LOAD - A load applied along the bearing bore axis.

RADIAL LIMIT LOAD - The static load required to produce a specified increase in radial play or permanent set in the bearing structure.

Values are based on the basic relationship: Limit Load (lbs) = KND^2 ,

where:

K = Load Rating Constant (typically 3200 for rod end bearings)

N = Number of Balls

D = Ball Diameter (inch)

AXIAL LIMIT LOAD - The static load required to produce a specified increase in axial play or permanent set in the bearing structure.

FRACTURE LOAD, RADIAL OR AXIAL - The load that can be applied to a bearing without fracturing parts or preventing free turning by hand.

The fracture load rating is usually 1.5 times the limit load.

DYNAMIC RADIAL LOAD - Load based on average "L-50" life of 10,000 complete 90° oscillatory cycles. Bearing failure is based upon inspection for evidence of pitting or surface fatigue on the balls or raceways.

Load ratings for a greater number of cycles may be determined by multiplying the basic load rating by a factor obtained from the life factor chart. (Figure 52)



HT, HT-V, WHT, WHT-V

Spherical Bearings - Self-Lubricating AS81820

For MS to NMB part number interchangeability, see page 33. Bearings in the tables below are approved for procurement to AS81820 and MS14101 through MS14104.

Temperature: Operating temperature range per MIL-B-81820 is -65° to 325°F (-54° to 163°C). Broader temperature capabilities are achievable

- Options:
1. For race Cadmium plate, see part number interchange page 32.
 2. For "K" type ("T" type in NMB P/N) low torque bearings with NO-LOAD ROTATIONAL BREAKAWAY TORQUE below .10 In·lb (0.01 N·m), see page 32 for radial clearance.
 3. For other options, see part number interchange page 32.

MATERIALS

Part No.	Ball	Race	Liner
Catalog No.	CRES 440C, AMS 5630, 55-62 HRC	CRES 17-4PH, AMS 5643, 28-37 HRC	*Teflon®/Fabric Bonded to race I.D.No lub.required
Catalog No. + PH	CRES PH13-8Mo AMS 5629 Cond. H-1000 (43 HRC MIN)	CRES17-4PH, AMS 5643, 28-37 HRC	*Teflon®/Fabric Bonded to race I.D.No lub.required

NMB Part Number		(B) Bore Diameter		(D) Outside Diameter		(W) Ball Width		(H) Race Width		(O) Shoulder Diameter		(C) Ball Diameter		(Q) Race Chamfered × 45°		(Q) Misalignment
Chamfered	V-Grooved	Inch	mm	Inch	mm	Inch	mm	Inch	mm	Inch	mm	Inch	mm	Inch	mm	
NARROW		+0.000	+0.000	+0.000	+0.000	+0.000	+0.000							+0.000	+0.000	
MS 14104	MS14101	-.0005	-0.013	-.0005	-0.013	-.002	-0.05	±.005	±0.13	MIN	MIN	Ref.	Ref.	-.010	-0.25	Ref.
HT3	HT3V	.1900	4.826	.5625	14.288	.281	7.14	.218	5.54	.293	7.44	.406	10.31	.020	0.51	10°
HT4	HT4V	.2500	6.350	.6562	16.667	.343	8.71	.250	6.35	.364	9.25	.500	12.70	.020	0.51	10°
HT5	HT5V	.3125	7.938	.7500	19.050	.375	9.52	.281	7.14	.419	10.64	.570	14.48	.020	0.51	10°
—	HT5AV	.3125	7.938	.7500	19.050	.375	9.52	.281	7.14	.419	10.64	.570	14.48	—	—	10°
HT6	HT6V	.3750	9.525	.8125	20.638	.406	10.31	.312	7.92	.475	12.06	.656	16.66	.030	0.76	9°
HT7	HT7V	.4375	11.112	.9062	23.017	.437	11.10	.343	8.71	.530	13.46	.718	18.24	.030	0.76	8°
HT8	HT8V	.5000	12.700	1.0000	25.400	.500	12.70	.390	9.91	.600	15.24	.781	19.84	.030	0.76	8°
HT9	HT9V	.5625	14.288	1.0937	27.780	.562	14.27	.437	11.10	.670	17.02	.875	22.22	.030	0.76	8°
HT10	HT10V	.6250	15.875	1.1875	30.162	.625	15.88	.500	12.70	.739	18.77	1.000	25.40	.030	0.76	8°
HT12	HT12V	.7500	19.050	1.4375	36.512	.750	19.05	.593	15.06	.920	23.37	1.250	31.75	.040	1.02	8°
HT14	HT14V	.8750	22.225	1.5625	39.688	.875	22.22	.703	17.86	.980	24.89	1.375	34.92	.040	1.02	8°
HT16	HT16V	1.0000	25.400	1.7500	44.450	1.000	25.40	.797	20.24	1.118	28.40	1.562	39.67	.040	1.02	9°
WIDE																
MS14102	MS14103															
WHT3	WHT3V	.1900	4.826	.6250	15.875	.437	11.10	.327	8.31	.300	7.62	.531	13.49	.020	0.51	15°
WHT4	WHT4V	.2500	6.350	.6250	15.875	.437	11.10	.327	8.31	.300	7.62	.531	13.49	.020	0.51	15°
WHT5	WHT5V	.3125	7.938	.6875	17.462	.437	11.10	.317	8.05	.360	9.14	.570	14.48	.020	0.51	14°
WHT6	WHT6V	.3750	9.525	.8125	20.638	.500	12.70	.406	10.31	.466	11.84	.687	17.45	.030	0.76	8°
WHT7	WHT7V	.4375	11.112	.9375	23.812	.562	14.27	.442	11.23	.537	13.64	.781	19.84	.030	0.76	10°
—	WHT7AV	.4375	11.112	.9062	23.017	.562	14.27	.442	11.23	.537	13.64	.781	19.84	—	—	10°
WHT8	WHT8V	.5000	12.700	1.0000	25.400	.625	15.88	.505	12.83	.607	15.42	.875	22.22	.030	0.76	9°
WHT9	WHT9V	.5625	14.288	1.1250	28.575	.687	17.45	.536	13.61	.721	18.31	1.000	25.40	.030	0.76	10°
WHT10	WHT10V	.6250	15.875	1.1875	30.162	.750	19.05	.567	14.40	.747	18.97	1.062	26.97	.030	0.76	12°
WHT12	WHT12V	.7500	19.050	1.3750	34.925	.875	22.22	.630	16.00	.845	21.46	1.250	31.75	.040	1.02	13°
WHT14	WHT14V	.8750	22.225	1.6250	41.275	.875	22.22	.755	19.18	.995	25.27	1.375	34.92	.040	1.02	6°
WHT16	WHT16V	1.0000	25.400	2.1250	53.975	1.375	34.92	1.005	25.53	1.269	32.23	1.875	47.62	.040	1.02	12°

* A trade name of E.I. duPont de Nemours & Co., Inc.

OVERSIZE BEARING DIMENSION (OUTSIDE DIAMETER) (MS 14104, MS14101)

DASH No	Nominal Bore Size	1st Oversize	2nd Oversize	DASH No	Nominal Bore Size	1st Oversize	2nd Oversize
-3	.1900 (4.826mm)	.5725 (14.542mm)	.5825 (14.800mm)	-9	.5625 (14.288mm)	1.1037 (28.034mm)	1.1137 (28.288mm)
-4	.2500 (6.350mm)	.6662 (16.921mm)	.6762 (17.175mm)	-10	.6250 (15.875mm)	1.1975 (30.416mm)	1.2075 (30.670mm)
-5(A)	.3125 (7.938mm)	.7600 (19.304mm)	.7700 (19.558mm)	-12	.7500 (19.050mm)	1.4475 (36.766mm)	1.4575 (37.020mm)
-6	.3750 (9.525mm)	.8225 (20.892mm)	.8325 (21.146mm)	-14	.8750 (22.225mm)	1.5725 (39.942mm)	1.5825 (40.196mm)
-7	.4375 (11.112mm)	.9162 (23.271mm)	.9262 (23.525mm)	-16	1.0000 (25.400mm)	1.7600 (44.704mm)	1.7700 (44.958mm)
-8	.5000 (12.700mm)	1.0100 (25.654mm)	1.0200 (25.908mm)				

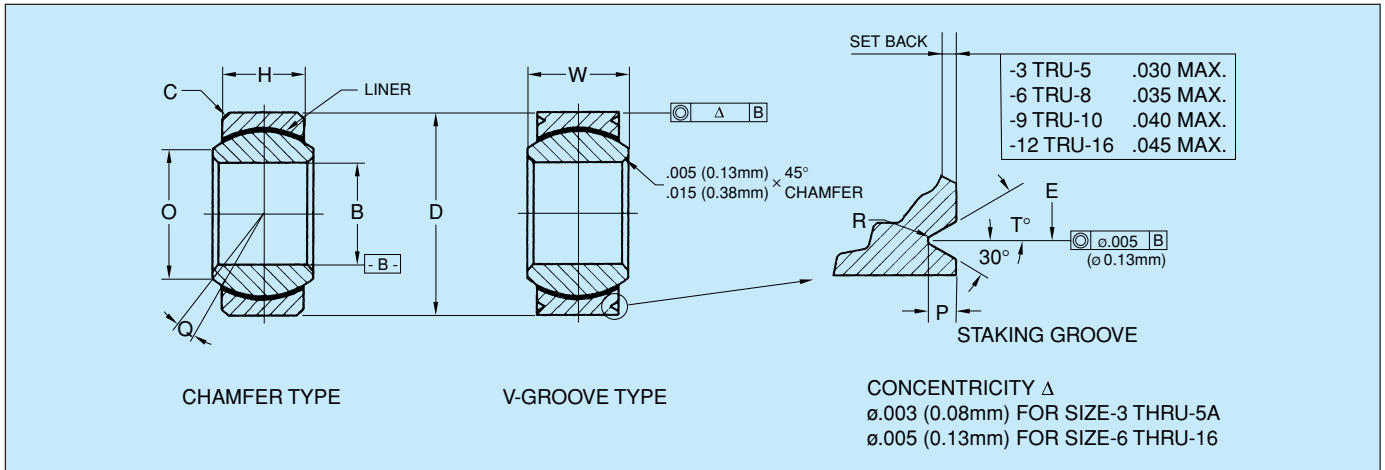

(E) Pitch Diameter		Staking Groove Data				(T)	No Load Rotational Breakaway Torque Standard "K" Type				Static Limit Load		Dynamic Osc. Radial Load		Approx. Weight			
Inch	mm	Inch	mm	Inch	mm		In-lb	N-m	In-lb	N-m	lbs	N	lbs	N	lbs	kg		
+0.00	+0.00	+0.00	+0.00															
-0.08	-0.20	-0.10	-0.25															
.500	12.70	.025	0.64	.005-.010	0.13-0.25	20° MIN	0.25-5.0	0.03-0.56	0-0.5	0-0.06	3975	17681	150	667	1500	6672	.020	0.009
.594	15.09	.025	0.64	.005-.010	0.13-0.25	20° MIN	0.25-5.0	0.03-0.56	0-0.5	0-0.06	6040	26866	430	1913	3320	14767	.020	0.009
.650	16.51	.035	0.89	.005-.010	0.13-0.25	30°	0.25-8.0	0.03-0.90	0-1.0	0-0.11	8750	38920	700	3114	5460	24286	.030	0.014
.660	16.76	.035	0.89	.005-.010	0.13-0.25	20° MIN	0.25-8.0	0.03-0.90	0-1.0	0-0.11	8750	38920	700	3114	5460	24286	.030	0.014
.712	18.08	.035	0.89	.010-.017	0.25-0.43	30°	0.25-8.0	0.03-0.90	0-1.0	0-0.11	10540	46882	1100	4893	6600	29357	.040	0.018
.806	20.47	.035	0.89	.010-.017	0.25-0.43	30°	0.25-8.0	0.03-0.90	0-1.0	0-0.11	13200	58714	1400	6227	8050	35806	.050	0.023
.876	22.25	.055	1.40	.010-.017	0.25-0.43	30°	0.25-8.0	0.03-0.90	0-1.0	0-0.11	17900	79619	2100	9341	10400	46259	.070	0.032
.970	24.64	.055	1.40	.010-.017	0.25-0.43	30°	0.25-8.0	0.03-0.90	0-1.0	0-0.11	23200	103194	3680	16369	13000	57824	.090	0.041
1.063	27.00	.055	1.40	.010-.017	0.25-0.43	30°	0.25-8.0	0.03-0.90	0-1.0	0-0.11	30500	135664	4720	20995	16450	73170	.120	0.054
1.313	33.35	.055	1.40	.010-.017	0.25-0.43	30°	0.25-8.0	0.03-0.90	0-1.0	0-0.11	46400	206387	6750	30024	23600	104973	.210	0.095
1.438	36.53	.055	1.40	.010-.017	0.25-0.43	30°	0.25-12.0	0.03-1.36	0-2.0	0-0.23	62200	276666	9350	41589	30250	134552	.270	0.122
1.626	41.30	.055	1.40	.010-.017	0.25-0.43	30°	0.25-12.0	0.03-1.36	0-2.0	0-0.23	82200	365626	12160	54088	38000	169024	.390	0.177
.563	14.30	.025	0.64	.005-.012	0.13-0.30	20° MIN	0.25-5.0	0.03-0.56	0-0.5	0-0.06	2500	11120	1770	7873	4900	21795	.031	0.014
.563	14.30	.025	0.64	.005-.012	0.13-0.30	20° MIN	0.25-5.0	0.03-0.56	0-0.5	0-0.06	5500	24464	1770	7873	4900	21795	.031	0.014
.625	15.88	.025	0.64	.005-.012	0.13-0.30	30°	0.25-8.0	0.03-0.90	0-1.0	0-0.11	9400	41811	1640	7295	6050	26910	.035	0.016
.712	18.08	.035	0.89	.010-.017	0.25-0.43	30°	0.25-8.0	0.03-0.90	0-1.0	0-0.11	13700	60938	2630	11698	8310	36963	.060	0.027
.837	21.26	.035	0.89	.010-.017	0.25-0.43	30°	0.25-8.0	0.03-0.90	0-1.0	0-0.11	20700	92074	3650	16235	11750	52264	.080	0.036
.806	20.47	.040	1.02	.101-.020	0.25-0.51	30°	0.25-8.0	0.03-0.90	0-1.0	0-0.11	19700	87626	3650	16235	11750	52264	.080	0.036
.900	22.86	.035	0.89	.010-.017	0.25-0.43	30°	0.25-8.0	0.03-0.90	0-1.0	0-0.11	21400	95187	4970	22107	14950	66498	.100	0.045
1.025	26.04	.035	0.89	.010-.017	0.25-0.43	30°	0.25-8.0	0.03-0.90	0-1.0	0-0.11	26600	118317	5370	23886	18100	80509	.135	0.061
1.087	27.61	.035	0.89	.010-.017	0.25-0.43	30°	0.25-8.0	0.03-0.90	0-1.0	0-0.11	29000	128992	6130	27266	20250	90072	.160	0.073
1.251	31.78	.055	1.40	.010-.017	0.25-0.43	30°	0.25-8.0	0.03-0.90	0-1.0	0-0.11	37000	164576	7730	34383	26200	116538	.240	0.109
1.501	38.13	.055	1.40	.010-.017	0.25-0.43	30°	0.25-12.0	0.03-1.36	0-2.0	0-0.23	65200	290010	10800	48038	33600	149453	.350	0.159
2.001	50.83	.055	1.40	.010-.017	0.25-0.43	30°	0.25-12.0	0.03-1.36	0-2.0	0-0.23	104000	462592	19300	85846	56250	250200	.970	0.440

(MS 14102. MS14103)

DASH No	Nominal Bore Size	1st Oversize	2nd Oversize	DASH No	Nominal Bore Size	1st Oversize	2nd Oversize
-3	.1900 (4.826mm)	.6350 (16.129mm)	.6450 (16.383mm)	-8	.5000 (12.700mm)	1.0100 (25.654mm)	1.0200 (25.908mm)
-4	.2500 (6.350mm)	.6350 (16.129mm)	.6450 (16.383mm)	-9	.5625 (14.288mm)	1.1350 (28.829mm)	1.1450 (29.083mm)
-5	.3125 (7.938mm)	.6975 (17.716mm)	.7075 (17.970mm)	-10	.6250 (15.875mm)	1.1975 (30.416mm)	1.2075 (30.670mm)
-6	.3750 (9.525mm)	.8225 (20.892mm)	.9575 (24.320mm)	-12	.7500 (19.050mm)	1.3850 (35.179mm)	1.3950 (35.433mm)
-7	.4375 (11.112mm)	.9475 (24.066mm)	.9575 (24.320mm)	-14	.8750 (22.225mm)	1.6350 (41.529mm)	1.6450 (41.783mm)
-7A	.4375 (11.112mm)	.9162 (23.271mm)	.9262 (23.525mm)	-16	1.0000 (25.400mm)	2.1350 (54.229mm)	2.1450 (54.483mm)



Special Bearings AS81820

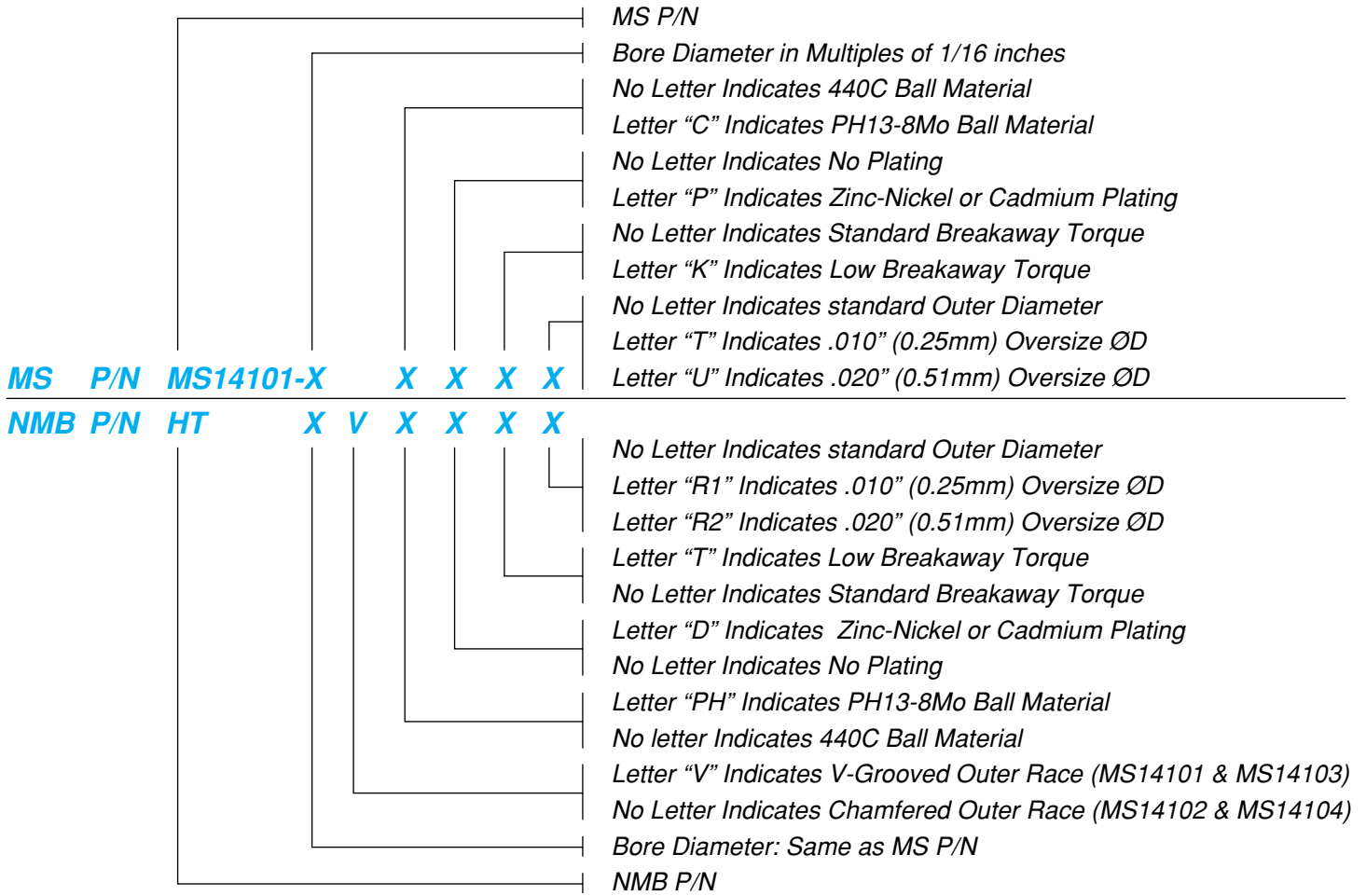

MS P/N	NMB P/N	DESCRIPTION
MS 14101	HT-V	Narrow Grooved
MS 14102	WHT	Wide Chamfered
MS 14103	WHT-V	Wide Grooved
MS 14104	HT	Narrow Chamfered

Notes: 1. “K” Type (“T” Type in NMB) Low Torque Bearings

No load torque: When the letter “K” is present in the MS P/N, lower values of NO LOAD TORQUE are as specified on page 31. If the measured torque of a “K” type bearing is less than .1 In·lb (0.01 N·m), the internal radial play shall be measured and shall not exceed the following:

SERIES MS14101 & MS14104			SERIES MS14102 & MS14103		
Bore Size	MAX Radial Play	MAX Axial Play	Bore Size	MAX Radial Play	MAX Axial Play
3K Thru 12K	.0007 Inch (0.018mm)	.0028 Inch (0.071mm)	3K Thru 12K	.0007 Inch (0.018mm)	.0021 Inch (0.053mm)
14K Thru 16K	.0010 Inch (0.025mm)	.0040 Inch (0.102mm)	14K Thru 16K	.0010 Inch (0.025mm)	.0030 Inch (0.076mm)

2. Cadmium Plating

Cadmium plate per AMS-QQ-P-416 Type II Class 2 on O. D. and O. D. chamfers for MS14101 & MS14103. Cadmium plate AMS-QQ-P-416 Type II Class 2 on O. D. and on the flats between the outside diameter and grooves for MS14102 and MS14104 Dimensions apply after plating.

MS to NMB Part Numbers

MS14101 SERIES

MS	NMB	MS	NMB	MS	NMB	MS	NMB
MS14101-3	HT3V	MS14101-3C	HT3VPH	MS14101-3P	HT3VD	MS14101-3K	HT3VT
MS14101-4	HT4V	MS14101-4C	HT4VPH	MS14101-4P	HT4VD	MS14101-4K	HT4VT
MS14101-5	HT5V	MS14101-5C	HT5VPH	MS14101-5P	HT5VD	MS14101-5K	HT5VT
MS14101-5A	HT5AV	MS14101-5AC	HT5AVPH	MS14101-5AP	HT5AVD	MS14101-5AK	HT5AVT
MS14101-6	HT6V	MS14101-6C	HT6VPH	MS14101-6P	HT6VD	MS14101-6K	HT6VT
MS14101-7	HT7V	MS14101-7C	HT7VPH	MS14101-7P	HT7VD	MS14101-7K	HT7VT
MS14101-8	HT8V	MS14101-8C	HT8VPH	MS14101-8P	HT8VD	MS14101-8K	HT8VT
MS14101-9	HT9V	MS14101-9C	HT9VPH	MS14101-9P	HT9VD	MS14101-9K	HT9VT
MS14101-10	HT10V	MS14101-10C	HT10VPH	MS14101-10P	HT10VD	MS14101-10K	HT10VT
MS14101-12	HT12V	MS14101-12C	HT12VPH	MS14101-12P	HT12VD	MS14101-12K	HT12VT
MS14101-14	HT14V	MS14101-14C	HT14VPH	MS14101-14P	HT14VD	MS14101-14K	HT14VT
MS14101-16	HT16V	MS14101-16C	HT16VPH	MS14101-16P	HT16VD	MS14101-16K	HT16VT

MS14102 SERIES

MS	NMB	MS	NMB	MS	NMB	MS	NMB
MS14102-3	WHT3	MS14102-3C	WHT3PH	MS14102-3P	WHT3D	MS14102-3K	WHT3T
MS14102-4	WHT4	MS14102-4C	WHT4PH	MS14102-4P	WHT4D	MS14102-4K	WHT4T
MS14102-5	WHT5	MS14102-5C	WHT5PH	MS14102-5P	WHT5D	MS14102-5K	WHT5T
MS14102-6	WHT6	MS14102-6C	WHT6PH	MS14102-6P	WHT6D	MS14102-6K	WHT6T
MS14102-7	WHT7	MS14102-7C	WHT7PH	MS14102-7P	WHT7D	MS14102-7K	WHT7T
MS14102-8	WHT8	MS14102-8C	WHT8PH	MS14102-8P	WHT8D	MS14102-8K	WHT8T
MS14102-9	WHT9	MS14102-9C	WHT9PH	MS14102-9P	WHT9D	MS14102-9K	WHT9T
MS14102-10	WHT10	MS14102-10C	WHT10PH	MS14102-10P	WHT10D	MS14102-10K	WHT10T
MS14102-12	WHT12	MS14102-12C	WHT12PH	MS14102-12P	WHT12D	MS14102-12K	WHT12T
MS14102-14	WHT14	MS14102-14C	WHT14PH	MS14102-14P	WHT14D	MS14102-14K	WHT14T
MS14102-16	WHT16	MS14102-16C	WHT16PH	MS14102-16P	WHT16D	MS14102-16K	WHT16T

MS14103 SERIES

MS	NMB	MS	NMB	MS	NMB	MS	NMB
MS14103-3	WHT3V	MS14103-3C	WHT3VPH	MS14103-3P	WHT3VD	MS14103-3K	WHT3VT
MS14103-4	WHT4V	MS14103-4C	WHT4VPH	MS14103-4P	WHT4VD	MS14103-4K	WHT4VT
MS14103-5	WHT5V	MS14103-5C	WHT5VPH	MS14103-5P	WHT5VD	MS14103-5K	WHT5VT
MS14103-6	WHT6V	MS14103-6C	WHT6VPH	MS14103-6P	WHT6VD	MS14103-6K	WHT6VT
MS14103-7	WHT7V	MS14103-7C	WHT7VPH	MS14103-7P	WHT7VD	MS14103-7K	WHT7VT
MS14103-7A	WHT7AV	MS14103-7AC	WHT7AVPH	MS14103-7AP	WHT7AVD	MS14103-7AK	WHT7AVT
MS14103-8	WHT8V	MS14103-8C	WHT8VPH	MS14103-8P	WHT8VD	MS14103-8K	WHT8VT
MS14103-9	WHT9V	MS14103-9C	WHT9VPH	MS14103-9P	WHT9VD	MS14103-9K	WHT9VT
MS14103-10	WHT10V	MS14103-10C	WHT10VPH	MS14103-10P	WHT10VD	MS14103-10K	WHT10VT
MS14103-12	WHT12V	MS14103-12C	WHT12VPH	MS14103-12P	WHT12VD	MS14103-12K	WHT12VT
MS14103-14	WHT14V	MS14103-14C	WHT14VPH	MS14103-14P	WHT14VD	MS14103-14K	WHT14VT
MS14103-16	WHT16V	MS14103-16C	WHT16VPH	MS14103-16P	WHT16VD	MS14103-16K	WHT16VT

MS14104 SERIES

MS	NMB	MS	NMB	MS	NMB	MS	NMB
MS14104-3	HT3	MS14104-3C	HT3PH	MS14104-3P	HT3D	MS14104-3K	HT3T
MS14104-4	HT4	MS14104-4C	HT4PH	MS14104-4P	HT4D	MS14104-4K	HT4T
MS14104-5	HT5	MS14104-5C	HT5PH	MS14104-5P	HT5D	MS14104-5K	HT5T
MS14104-6	HT6	MS14104-6C	HT6PH	MS14104-6P	HT6D	MS14104-6K	HT6T
MS14104-7	HT7	MS14104-7C	HT7PH	MS14104-7P	HT7D	MS14104-7K	HT7T
MS14104-8	HT8	MS14104-8C	HT8PH	MS14104-8P	HT8D	MS14104-8K	HT8T
MS14104-9	HT9	MS14104-9C	HT9PH	MS14104-9P	HT9D	MS14104-9K	HT9T
MS14104-10	HT10	MS14104-10C	HT10PH	MS14104-10P	HT10D	MS14104-10K	HT10T
MS14104-12	HT12	MS14104-12C	HT12PH	MS14104-12P	HT12D	MS14104-12K	HT12T
MS14104-14	HT14	MS14104-14C	HT14PH	MS14104-14P	HT14D	MS14104-14K	HT14T
MS14104-16	HT16	MS14104-16C	HT16PH	MS14104-16P	HT16D	MS14104-16K	HT16T



HTL, HTL-V, WHTL, WHTL-V

Spherical Bearings - Self-Lubricating
AS81820, Lined Bore Series

For MS to NMB part number interchangeability, see page 37. Bearings in the tables below are approved for procurement to AS81820/1 through AS81820/4.

Temperature: Operating temperature range per MIL-B-81820 is -65° to 325°F (-54° to 163°C). Broader temperature capabilities are achievable

- Options:
1. For race Cadmium plate, see part number interchange page 36.
 2. For “K” type (“T” type in NMB P/N) low torque bearings with NO-LOAD ROTATIONAL BREAKAWAY TORQUE below .10 In·lb (0.01 N·m), see page 36 for radial clearance.
 3. For other options, see part number interchange page 36.

MATERIALS

Part No.	Ball	Race	Liner
Catalog No.	CRES PH13-8Mo AMS 5629, Cond. H-1000 (43 HRC MIN)	CRES 17-4PH, AMS 5643, 28-37 HRC	*Teflon/Fabric Bonded to race I.D. & Ball Bore No. Lub. Req'd.

NMB Part Number		(B) Bore Diameter		(D) Outside Diameter		(W) Ball Width		(H) Race Width		Ball Diameter		(C) Race Chamfered × 45°		(Q) Misalign-ment
Chamfered	V-Grooved	Inch	mm	Inch	mm	Inch	mm	Inch	mm	Inch	mm	Inch	mm	
NARROW														
AS81820/4	AS81820/1	-.0010	-0.025	-.0010	-0.013	-.002	-0.05	±.005	±0.13	Ref.	Ref.	-.010	-0.25	Ref.
HTL4	HTL4V	.2510	6.375	.6562	16.667	.343	8.71	.250	6.35	.500	12.70	.020	0.51	10°
HTL5	HTL5V	.3135	7.963	.7500	19.050	.375	9.52	.281	7.14	.570	14.48	.020	0.51	10°
HTL6	HTL6V	.3760	9.550	.8125	20.638	.406	10.31	.312	7.92	.656	16.66	.030	0.76	9°
HTL7	HTL7V	.4385	11.138	.9062	23.017	.437	11.10	.343	8.71	.718	18.24	.030	0.76	8°
HTL8	HTL8V	.5010	12.725	1.0000	25.400	.500	12.70	.390	9.91	.781	19.84	.030	0.76	8°
HTL9	HTL9V	.5635	14.313	1.0937	27.780	.562	14.27	.437	11.10	.875	22.22	.030	0.76	8°
HTL10	HTL10V	.6260	15.900	1.1875	30.162	.625	15.88	.500	12.70	1.000	25.40	.030	0.76	8°
HTL12	HTL12V	.7510	19.075	1.4375	36.512	.750	19.05	.593	15.06	1.250	31.75	.040	1.02	8°
HTL14	HTL14V	.8760	22.250	1.5625	39.688	.875	22.22	.703	17.86	1.375	34.92	.040	1.02	8°
HTL16	HTL16V	1.0010	25.425	1.7500	44.450	1.000	25.40	.797	20.24	1.562	39.67	.040	1.02	9°
WIDE														
AS81820	AS81820/3													
WHTL5	WHTL5V	.3135	7.963	.6875	17.462	.437	11.10	.317	8.05	.570	14.48	.020	0.51	14°
WHTL6	WHTL6V	.3760	9.550	.8125	20.638	.500	12.70	.406	10.31	.687	17.45	.030	0.76	8°
WHTL7	WHTL7V	.4385	11.138	.9375	23.812	.562	14.27	.442	11.23	.781	19.84	.030	0.76	10°
—	WHTL7AV	.4385	11.138	.9062	23.017	.562	14.27	.442	11.23	.781	19.84	.030	0.76	10°
WHTL8	WHTL8V	.5010	12.725	1.0000	25.400	.625	15.88	.505	12.83	.875	22.22	.030	0.76	9°
WHTL9	WHTL9V	.5635	14.313	1.1250	28.575	.687	17.45	.536	13.61	1.000	25.40	.030	0.76	10°
WHTL10	WHTL10V	.6260	15.900	1.1875	30.162	.750	19.05	.567	14.40	1.062	26.97	.030	0.76	12°
WHTL12	WHTL12V	.7510	19.075	1.3750	34.925	.875	22.22	.630	16.00	1.250	31.75	.040	1.02	13°
WHTL14	WHTL14V	.8760	22.250	1.6250	41.275	.875	22.22	.755	19.18	1.375	34.92	.040	1.02	6°
WHTL16	WHTL16V	1.0010	25.425	2.1250	53.975	1.375	34.92	1.005	25.53	1.875	47.62	.040	1.02	12°

* A trade name of E.I. duPont de Nemours & Co., Inc.

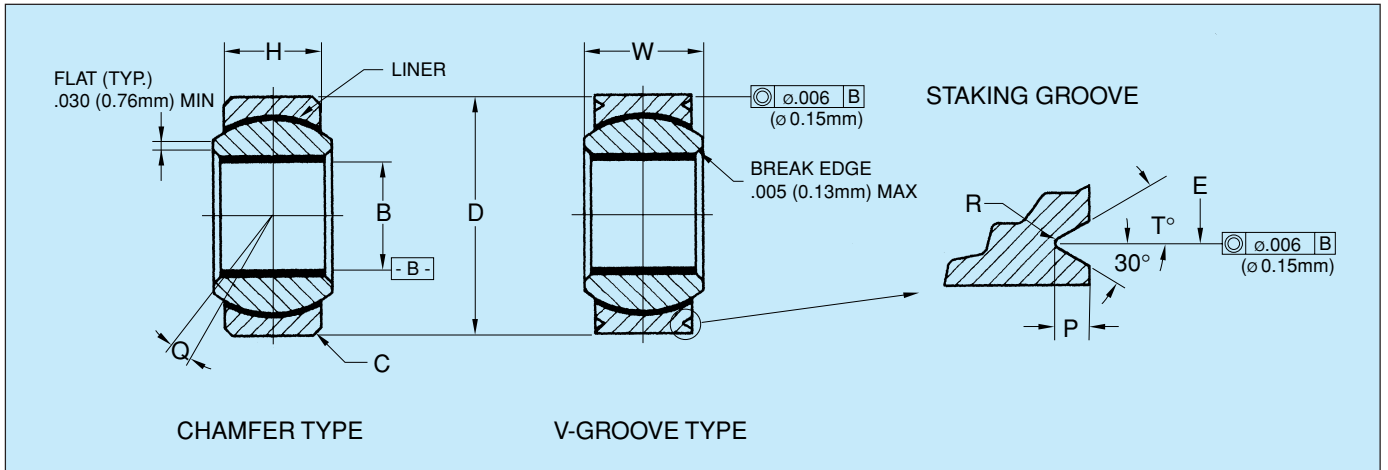

(E) Pitch Diameter		Staking Groove Data (P)				(R)		(T)	No Load Rotational Breakaway Torque Standard "K" Type				Static Limit Load Radial Axial		Dynamic Osc. Radial Load		Approx. Weight			
Inch	mm	Inch	mm	Inch	mm	Inch	mm		In-lb	N-m	In-lb	N-m	lbs	N	lbs	N	lbs	N	lbs	kg
+0.00	+0.00	+0.00	+0.00																	
-0.08	-0.20	-0.10	-0.25																	
.650	15.09	.025	0.63	.005-.010	0.13-0.25	20°MIN		1.0-5.0	0.11-0.56	0-0.5	0-0.06	5550	24686	430	1913	2650	11787	.020	.009	
.660	16.76	.035	0.89	.005-.010	0.13-0.25	20°MIN		1.0-15.0	0.11-1.69	0-1.0	0-0.11	7700	34250	700	3114	3700	16458	.030	.014	
.712	18.08	.035	0.89	.010-.017	0.25-0.43	30°		1.0-15.0	0.11-1.69	0-1.0	0-0.11	10200	45370	1100	4893	4900	21795	.040	.018	
.806	20.47	.035	0.89	.010-.017	0.25-0.43	30°		1.0-15.0	0.11-1.69	0-1.0	0-0.11	12950	57602	1400	6227	6700	29802	.050	.023	
.876	22.25	.055	1.40	.010-.017	0.25-0.43	30°		1.0-15.0	0.11-1.69	0-1.0	0-0.11	17250	76728	2100	9341	8250	36696	.070	.032	
.970	24.64	.055	1.40	.010-.017	0.25-0.43	30°		1.0-15.0	0.11-1.69	0-1.0	0-0.11	22150	98523	3680	16369	10600	47149	.090	.041	
1.063	27.00	.055	1.40	.010-.017	0.25-0.43	30°		1.0-15.0	0.11-1.69	0-1.0	0-0.11	27700	123210	4720	20995	13250	58936	.120	.054	
1.313	33.35	.055	1.40	.010-.017	0.25-0.43	30°		1.0-15.0	0.11-1.69	0-1.0	0-0.11	40600	180589	6750	30024	19400	86291	.210	.095	
1.438	36.53	.055	1.40	.010-.017	0.25-0.43	30°		1.0-25.0	0.11-2.82	0-2.0	0-0.23	55950	248866	9350	41589	26750	118984	.270	.122	
1.626	41.30	.055	1.40	.010-.017	0.25-0.43	30°		1.0-25.0	0.11-2.82	0-2.0	0-0.23	73800	328262	12160	54088	35250	156792	.390	.177	
.625	15.88	.025	0.63	.005-.012	0.13-0.30	30°		1.0-15.0	0.11-1.69	0-1.0	0-0.11	9300	41366	1640	7295	4450	19794	.035	0.016	
.712	18.08	.035	0.89	.010-.017	0.13-0.43	30°		1.0-15.0	0.11-1.69	0-1.0	0-0.11	13000	57824	2630	11698	6200	27578	.060	0.027	
.837	21.26	.035	0.89	.010-.017	0.13-0.43	30°		1.0-15.0	0.11-1.69	0-1.0	0-0.11	17300	76950	3650	16235	8250	36696	.080	0.036	
.806	20.47	.035	0.89	.010-.017	0.25-0.43	30°		1.0-15.0	0.11-1.69	0-1.0	0-0.11	17300	76950	3650	16235	8250	36696	.080	0.036	
.900	22.86	.035	0.89	.010-.017	0.25-0.43	30°		1.0-15.0	0.11-1.69	0-1.0	0-0.11	21400	95187	4790	22107	10600	47149	.100	0.045	
1.025	26.04	.035	0.89	.010-.017	0.25-0.43	30°		1.0-15.0	0.11-1.69	0-1.0	0-0.11	26600	118317	5370	23886	13200	58714	.135	0.061	
1.087	27.61	.035	0.89	.010-.017	0.25-0.43	30°		1.0-15.0	0.11-1.69	0-1.0	0-0.11	29000	128992	6130	27266	16150	71835	.160	0.073	
1.251	31.78	.055	1.40	.010-.017	0.25-0.43	30°		1.0-15.0	0.11-1.69	0-1.0	0-0.11	37000	164576	7730	34383	24800	110310	.240	0.109	
1.501	38.13	.055	1.40	.010-.017	0.25-0.43	30°		1.0-25.0	0.11-2.82	0-2.0	0-0.23	56000	249088	10800	48038	26750	118984	.350	0.159	
2.001	50.83	.055	1.40	.010-.017	0.25-0.43	30°		1.0-25.0	0.11-2.82	0-2.0	0-0.23	103000	458144	19300	85846	49300	219286	.970	0.440	

OVERSIZE BEARING DIMENSION (OUTSIDE DIAMETER)
(AS81820/1, AS81820/4)

DASH No	Nominal Bore Size	1st Oversize	2nd Oversize
-4	.2510 (6.375mm)	.6662 (16.921mm)	.6762 (17.175mm)
-5	.3135 (7.963mm)	.7600 (19.304mm)	.7700 (19.558mm)
-6	.3760 (9.550mm)	.8225 (20.892mm)	.8325 (21.146mm)
-7	.4385 (11.138mm)	.9162 (23.271mm)	.9262 (23.525mm)
-8	.5010 (12.725mm)	1.0100 (25.654mm)	1.0200 (25.908mm)
-9	.5635 (14.313mm)	1.1037 (28.034mm)	1.1137 (28.288mm)
-10	.6260 (15.900mm)	1.1975 (30.416mm)	1.2075 (30.670mm)
-12	.7510 (19.075mm)	1.4475 (36.766mm)	1.4575 (37.020mm)
-14	.8760 (22.250mm)	1.5725 (39.942mm)	1.5825 (40.196mm)
-16	1.0010 (25.425mm)	1.7600 (44.704mm)	1.7700 (44.958mm)

(AS81820/2, AS81820/3)

DASH No	Nominal Bore Size	1st Oversize	2nd Oversize
-5	.3135 (7.963mm)	.6975 (17.716mm)	.7075 (17.970mm)
-6	.3760 (9.550mm)	.8225 (20.892mm)	.8325 (21.146mm)
-7	.4385 (11.138mm)	.9475 (24.066mm)	.9575 (24.320mm)
-7A	.4385 (11.138mm)	.9162 (23.271mm)	.9262 (23.525mm)
-8	.5010 (12.725mm)	1.0100 (25.654mm)	1.0200 (25.908mm)
-9	.5635 (14.313mm)	1.1350 (28.829mm)	1.1450 (29.083mm)
-10	.6260 (15.900mm)	1.1975 (30.416mm)	1.2075 (30.670mm)
-12	.7510 (19.075mm)	1.3850 (35.179mm)	1.3950 (35.433mm)
-14	.8760 (22.250mm)	1.6350 (41.529mm)	1.6450 (41.783mm)
-16	1.0010 (25.425mm)	2.1350 (54.229mm)	2.1450 (54.483mm)



Special Bearings AS81820 Lined Bore Series

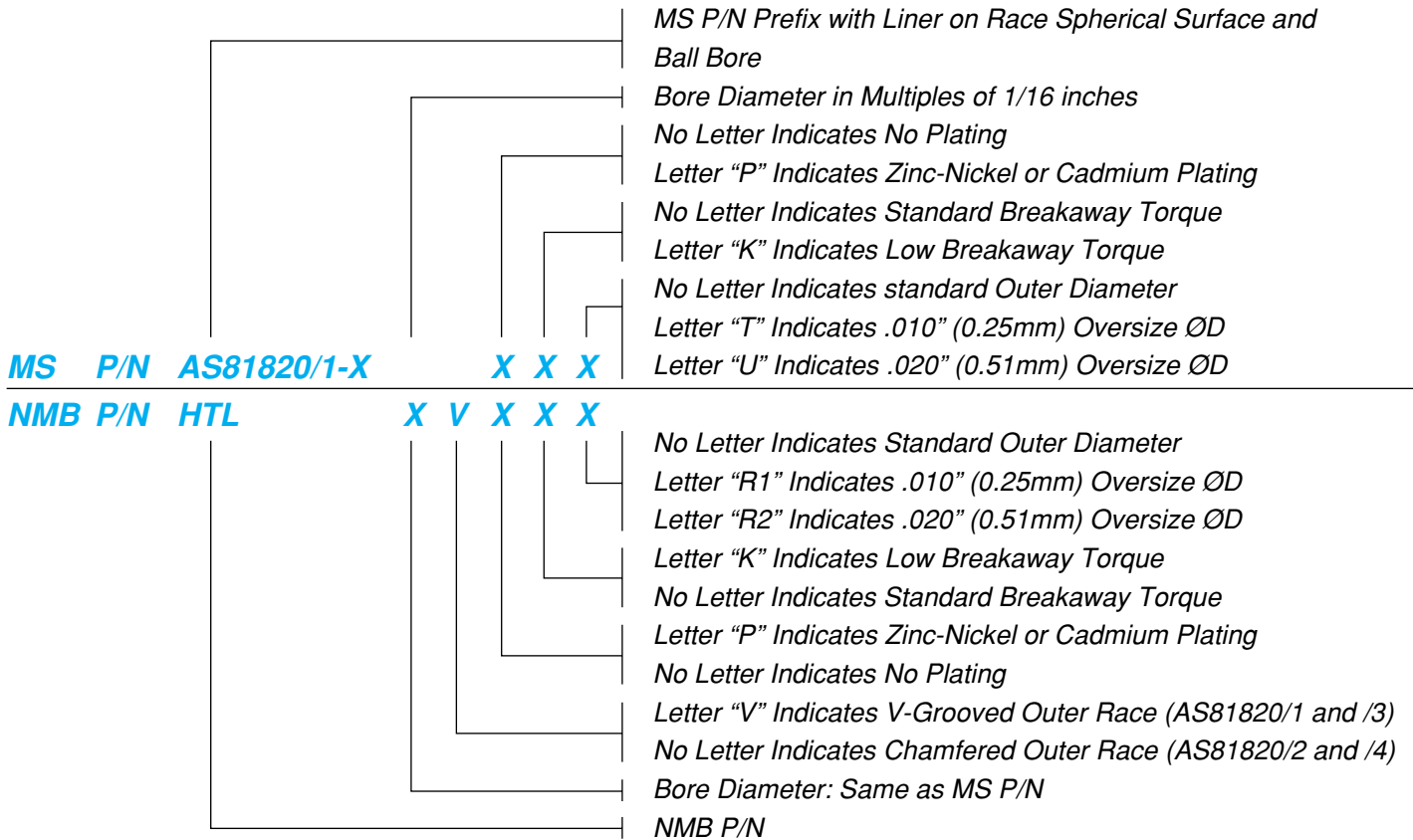

MS P/N	NMB P/N	DESCRIPTION
M81820/1	HTL-V	Narrow Grooved
M81820/2	WHTL	Wide Chamfered
M81820/3	WHTL-V	Wide Grooved
M81820/4	HTL	Narrow Chamfered

Notes: 1. "K" Type Low Torque Bearings

No load torque: When the letter "K" is present in the P/N lower values of NO LOAD TORQUE are as specified on page 35. If the measured torque of a "K" type bearing is less than .1 In·lb (0.01 N·m), requirements for torque or internal play between bearing and shaft are not defined in military specification. The internal radial play shall be measured and shall not exceed the torque and internal play between the spherical ball and the outer race as follows:

SERIES AS81820/1 & AS81820/4

Bore Size	MAX Radial Play	MAX Axial Play
-4K Thru - 12K	.0007 Inch (0.018mm)	.0028 Inch (0.071mm)
-14K Thru - 16K	.0010 Inch (0.025mm)	.0040 Inch (0.102mm)

SERIES AS81820/2 & AS81820/3

Bore Size	MAX Radial Play	MAX Axial Play
-5K Thru - 12K	.0007 Inch (0.018mm)	.0021 Inch (0.053mm)
-14K Thru - 16K	.0010 Inch (0.025mm)	.0030 Inch (0.076mm)

2. Cadmium Plating

Cadmium plate per AMS-QQ-P-416 Type II Class 2 on O. D. and O. D. chamfers for AS81820/2 & AS81820/4.

Cadmium plate AMS-QQ-P-416 Type II Class 2 on O. D. and on the flats between the outside diameter and grooves for AS81820/1 and AS81820/3.

Dimensions apply after plating.

MS to NMB Part Numbers

AS81820/1

MS	NMB	MS	NMB	MS	NMB
M81820/1-4	HTL4V	M81820/1-4P	HTL4VP	M81820/1-4K	HTL4VK
M81820/1-5	HTL5V	M81820/1-5P	HTL5VP	M81820/1-5K	HTL5VK
M81820/1-6	HTL6V	M81820/1-6P	HTL6VP	M81820/1-6K	HTL6VK
M81820/1-7	HTL7V	M81820/1-7P	HTL7VP	M81820/1-7K	HTL7VK
M81820/1-8	HTL8V	M81820/1-8P	HTL8VP	M81820/1-8K	HTL8VK
M81820/1-9	HTL9V	M81820/1-9P	HTL9VP	M81820/1-9K	HTL9VK
M81820/1-10	HTL10V	M81820/1-10P	HTL10VP	M81820/1-10K	HTL10VK
M81820/1-12	HTL12V	M81820/1-12P	HTL12VP	M81820/1-12K	HTL12VK
M81820/1-14	HTL14V	M81820/1-14P	HTL14VP	M81820/1-14K	HTL14VK
M81820/1-16	HTL16V	M81820/1-16P	HTL16VP	M81820/1-16K	HTL16VK

AS81820/2

MS	NMB	MS	NMB	MS	NMB
M81820/2-5	WHTL5	M81820/2-5P	WHTL5P	M81820/2-5K	WHTL5K
M81820/2-6	WHTL6	M81820/2-6P	WHTL6P	M81820/2-6K	WHTL6K
M81820/2-7	WHTL7	M81820/2-7P	WHTL7P	M81820/2-7K	WHTL7K
M81820/2-8	WHTL8	M81820/2-8P	WHTL8P	M81820/2-8K	WHTL8K
M81820/2-9	WHTL9	M81820/2-9P	WHTL9P	M81820/2-9K	WHTL9K
M81820/2-10	WHTL10	M81820/2-10P	WHTL10P	M81820/2-10K	WHTL10K
M81820/2-12	WHTL12	M81820/2-12P	WHTL12P	M81820/2-12K	WHTL12K
M81820/2-14	WHTL14	M81820/2-14P	WHTL14P	M81820/2-14K	WHTL14K
M81820/2-16	WHTL16	M81820/2-16P	WHTL16P	M81820/2-16K	WHTL16K

AS81820/3

MS	NMB	MS	NMB	MS	NMB
M81820/3-5	WHTL5V	M81820/3-5P	WHTL5VP	M81820/3-5K	WHTL5VK
M81820/3-6	WHTL6V	M81820/3-6P	WHTL6VP	M81820/3-6K	WHTL6VK
M81820/3-7	WHTL7V	M81820/3-7P	WHTL7VP	M81820/3-7K	WHTL7VK
M81820/3-7A	WHTL7AV	M81820/3-7AP	WHTL7AVP	M81820/3-7AK	WHTL7AVK
M81820/3-8	WHTL8V	M81820/3-8P	WHTL8VP	M81820/3-8K	WHTL8VK
M81820/3-9	WHTL9V	M81820/3-9P	WHTL9VP	M81820/3-9K	WHTL9VK
M81820/3-10	WHTL10V	M81820/3-10P	WHTL10VP	M81820/3-10K	WHTL10VK
M81820/3-12	WHTL12V	M81820/3-12P	WHTL12VP	M81820/3-12K	WHTL12VK
M81820/3-14	WHTL14V	M81820/3-14P	WHTL14VP	M81820/3-14K	WHTL14VK
M81820/3-16	WHTL16V	M81820/3-16P	WHTL16VP	M81820/3-16K	WHTL16VK

AS81820/4

MS	NMB	MS	NMB	MS	NMB
M81820/4-4	HTL4	M81820/4-4P	HTL4P	M81820/4-4K	HTL4K
M81820/4-5	HTL5	M81820/4-5P	HTL5P	M81820/4-5K	HTL5K
M81820/4-6	HTL6	M81820/4-6P	HTL6P	M81820/4-6K	HTL6K
M81820/4-7	HTL7	M81820/4-7P	HTL7P	M81820/4-7K	HTL7K
M81820/4-8	HTL8	M81820/4-8P	HTL8P	M81820/4-8K	HTL8K
M81820/4-9	HTL9	M81820/4-9P	HTL9P	M81820/4-9K	HTL9K
M81820/4-10	HTL10	M81820/4-10P	HTL10P	M81820/4-10K	HTL10K
M81820/4-12	HTL12	M81820/4-12P	HTL12P	M81820/4-12K	HTL12K
M81820/4-14	HTL14	M81820/4-14P	HTL14P	M81820/4-14K	HTL14K
M81820/4-16	HTL16	M81820/4-16P	HTL16P	M81820/4-16K	HTL16K



ABT, ABT-V, ABWT, ABWT-V

Spherical Bearings - Self-Lubricating
MIL-B-8942

Bearings in the tables below are approved for procurement to MIL-B-8942 and MS21230 through MS21233.
Temperature: Operating temperature range per MIL-B-8942 is -65° to 250°F (-54° to 121°C). Broader temperature capabilities are achievable.

MATERIALS

Part No.	Ball	Race	Liner
Catalog No.	CRES 440C AMS 5630, 55-62 HRC	CRES 410 AMS 5613, 23-35 HRC	*Teflon/Fabric Bonded to race I.D. No. Lub. Req'd.

* A trade name of E.I. duPont de Nemours & Co., Inc.
** Bore code "3" is not specified on MS21232, but may be ordered to NMB part number "ABT3V"

NMB Part Number		(B) Bore Diameter		(D) Outside Diameter		(W) Ball Width		(H) Race Width		(O) Shoulder Diameter		(C) Ball Diameter		(Q) Race Chamfered × 45°		(Q) Misalign-ment
Chamfered	V-Grooved	Inch	mm	Inch	mm	Inch	mm	Inch	mm	Inch	mm	Inch	mm	Inch	mm	MIN
NARROW		+0.000	+0.000	+0.000	+0.000	+0.000	+0.000	±0.005	±0.13	MIN	MIN	Ref.	Ref.	+0.000	+0.000	
MS21233	MS21232	-0.005	-0.013	-0.005	-0.013	-0.002	-0.05							-0.030	-0.076	MIN
ABT3	(ABT3V)**	.1900	4.826	.5625	14.288	.281	7.14	.218	5.54	.293	7.44	.406	10.31	.040	1.02	10°
ABT4	ABT4V	.2500	6.350	.6562	16.667	.343	8.71	.250	6.35	.364	9.25	.500	12.70	.040	1.02	10°
ABT5	ABT5V	.3125	7.938	.7500	19.050	.375	9.52	.281	7.14	.419	10.64	.562	14.27	.040	1.02	10°
ABT6	ABT6V	.3750	9.525	.8125	20.638	.406	10.31	.312	7.92	.475	12.06	.656	16.66	.040	1.02	9°
ABT7	ABT7V	.4375	11.112	.9062	23.017	.437	11.10	.343	8.71	.530	13.46	.718	18.24	.040	1.02	8°
ABT8-1	ABT8V-1	.5000	12.700	1.0000	25.400	.500	12.70	.390	9.91	.600	15.24	.813	20.65	.040	1.02	8°
ABT9-1	ABT9V-1	.5625	14.288	1.0937	27.780	.562	14.27	.437	11.10	.670	17.02	.906	23.01	.040	1.02	8°
ABT10	ABT10V	.6250	15.875	1.1875	30.162	.625	15.88	.500	12.70	.739	18.77	.968	24.59	.040	1.02	8°
ABT12	ABT12V	.7500	19.050	1.4375	36.512	.750	19.05	.593	15.06	.920	23.37	1.187	30.15	.040	1.02	8°
ABT14	ABT14V	.8750	22.225	1.5625	39.687	.875	22.22	.703	17.86	.980	24.89	1.312	33.32	.040	1.02	8°
ABT16	ABT16V	1.0000	25.400	1.7500	44.450	1.000	25.40	.797	20.24	1.118	28.40	1.500	38.10	.040	1.02	9°
WIDE																
MS21231	MS21230															
ABWT3	ABWT3V	.1900	4.826	.6250	15.875	.437	11.10	.327	8.31	.300	7.62	.531	13.49	.040	1.02	15°
ABWT4	ABWT4V	.2500	6.350	.6250	15.875	.437	11.10	.327	8.31	.300	7.62	.531	13.49	.040	1.02	15°
ABWT5	ABWT5V	.3125	7.938	.6875	17.462	.437	11.10	.317	8.05	.360	9.14	.593	15.06	.040	1.02	14°
ABWT6	ABWT6V	.3750	9.525	.8125	20.638	.500	12.70	.406	10.31	.466	11.84	.687	17.45	.040	1.02	8°
ABWT7	ABWT7V	.4375	11.112	.9375	23.812	.562	14.27	.442	11.23	.537	13.64	.781	19.84	.040	1.02	10°
ABWT8	ABWT8V	.5000	12.700	1.0000	25.400	.625	15.87	.505	12.83	.607	15.42	.875	22.22	.040	1.02	9°
ABWT9	ABWT9V	.5625	14.287	1.1250	28.575	.687	17.45	.536	13.61	.721	18.31	1.000	25.40	.040	1.02	10°
ABWT10	ABWT10V	.6250	15.875	1.1875	30.162	.750	19.05	.567	14.40	.747	18.97	1.062	26.97	.040	1.02	12°
ABWT12-1	ABWT12V-1	.7500	19.050	1.3750	34.925	.875	22.22	.630	16.00	.845	21.46	1.250	31.75	.040	1.02	13°
ABWT14	ABWT14V	.8750	22.225	1.6250	41.275	.875	22.22	.755	19.18	.995	25.27	1.375	34.92	.040	1.02	6°
ABWT16	ABWT16V	1.0000	25.400	2.1250	53.975	1.375	34.92	1.005	25.53	1.269	32.23	1.875	47.62	.040	1.02	12°

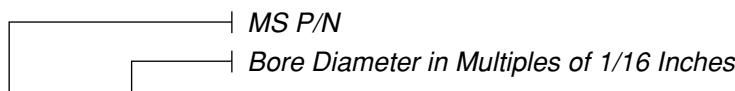

MS P/N MS21230-X

NMB P/N ABWT X V

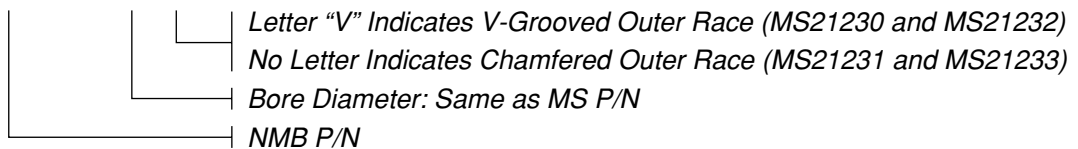

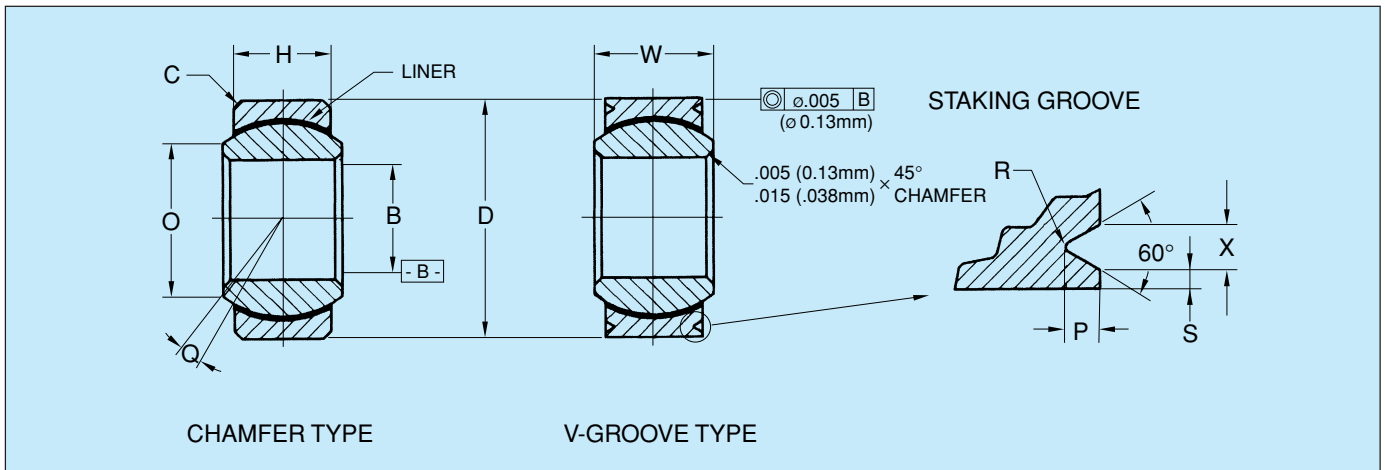

		Staking Groove Data								No Load Rotational Breakaway Torque		Static Limit Load		Dynamic Osc. Radial Load		Approx. Weight	
		(P)		(R)		(S)		(X)									
Inch	mm	Inch	mm	Inch	mm	Inch	mm	Inch	mm	In-lb	N-m	lbs	N	lbs	N	lbs	kg
+0.00	+0.00	+0.00	+0.00	+0.00	+0.00	+0.00	+0.00	+0.00	+0.00								
-.015	-.038	-.010	-.025	-.010	-.025	-.010	-.025	-.010	-.025								
.030	0.76	.015	0.38	.020	0.51	.045	1.14	.5-50	0.06-0.56	3975	17681	150	667	1500	6672	.020	0.009
.030	0.76	.015	0.38	.020	0.51	.045	1.14	1.0-5.0	0.12-0.56	6040	26866	430	1913	2320	10319	.020	0.009
.040	1.02	.020	0.51	.030	0.76	.055	1.40	1.0-5.0	0.12-0.56	8750	38920	700	3114	3430	15257	.030	0.014
.040	1.02	.020	0.51	.030	0.76	.055	1.40	1.0-5.0	0.12-0.56	10540	46882	1100	4893	4200	18682	.040	0.018
.040	1.02	.020	0.51	.030	0.76	.055	1.40	1.0-5.0	0.12-0.56	13200	58714	1400	6227	5700	25354	.050	0.023
.060	1.52	.020	0.51	.030	0.76	.080	2.03	1.0-5.0	0.12-0.56	17900	79619	2100	9341	7900	35139	.070	0.032
.060	1.52	.020	0.51	.030	0.76	.080	2.03	1.0-5.0	0.12-0.56	23200	103194	3680	16369	10300	45814	.090	0.041
.060	1.52	.020	0.51	.030	0.76	.080	2.03	1.0-5.0	0.12-0.56	30500	135664	4720	20995	13400	59603	.120	0.054
.060	1.52	.020	0.51	.030	0.76	.080	2.03	1.0-5.0	0.12-0.56	46400	206387	6750	30024	19700	87626	.210	0.095
.060	1.52	.020	0.51	.030	0.76	.080	2.03	2.0-8.0	0.23-0.90	62200	276666	9350	41589	26100	116093	.270	0.122
.060	1.52	.020	0.51	.030	0.76	.080	2.03	2.0-8.0	0.23-0.90	82200	365626	12160	54088	34100	151677	.390	0.177
.030	0.76	.015	0.38	.020	0.51	.045	1.14	.5-50	0.06-0.56	9000	40032	1770	7873	3770	16769	.031	0.014
.030	0.76	.015	0.38	.020	0.51	.045	1.14	1.0-5.0	0.12-0.56	9000	40032	1770	7873	3770	16769	.031	0.014
.030	0.76	.015	0.38	.020	0.51	.045	1.14	1.0-5.0	0.12-0.56	9400	41811	1640	7295	4650	20683	.035	0.016
.040	1.02	.020	0.51	.030	0.76	.055	1.40	1.0-5.0	0.12-0.56	13700	60938	2630	11698	6390	28423	.060	0.027
.040	1.02	.020	0.51	.030	0.76	.055	1.40	1.0-5.0	0.12-0.56	20700	92074	3650	16235	9390	41767	.080	0.036
.040	1.02	.020	0.51	.030	0.76	.055	1.40	1.0-5.0	0.12-0.56	27500	122320	4970	22107	12150	54043	.100	0.045
.040	1.02	.020	0.51	.030	0.76	.055	1.40	1.0-5.0	0.12-0.56	34400	153011	5370	23886	14900	66275	.135	0.061
.040	1.02	.020	0.51	.030	0.76	.055	1.40	1.0-5.0	0.12-0.56	39000	173472	6130	27266	16700	74282	.160	0.073
.060	1.52	.020	0.51	.030	0.76	.080	2.03	1.0-5.0	0.12-0.56	52300	232630	7730	34383	22100	98301	.240	0.109
.060	1.52	.020	0.51	.030	0.76	.080	2.03	2.0-8.0	0.23-0.90	67300	299350	10800	48038	28200	125434	.350	0.159
.060	1.52	.020	0.51	.030	0.76	.080	2.03	2.0-8.0	0.23-0.90	137000	609376	19300	85846	53700	238858	.970	0.440

MS21230	
MS	NMB
MS21230-3	ABWT3V
MS21230-4	ABWT4V
MS21230-5	ABWT5V
MS21230-6	ABWT6V
MS21230-7	ABWT7V
MS21230-8	ABWT8V
MS21230-9	ABWT9V
MS21230-10	ABWT10V
MS21230-12	ABWT12V
MS21230-14	ABWT14V
MS21230-16	ABWT16V

MS21231	
MS	NMB
MS21231-3	ABWT3
MS21231-4	ABWT4
MS21231-5	ABWT5
MS21231-6	ABWT6
MS21231-7	ABWT7
MS21231-8	ABWT8
MS21231-9	ABWT9
MS21231-10	ABWT10
MS21231-12	ABWT11
MS21231-14	ABWT14
MS21231-16	ABWT16

MS21232	
MS	NMB
MS21232-4	ABT4V
MS21232-5	ABT5V
MS21232-6	ABT6V
MS21232-7	ABT7V
MS21232-8	ABT8V
MS21232-9	ABT9V
MS21232-10	ABT10V
MS21232-12	ABT12V
MS21232-14	ABT14V
MS21232-16	ABT16V

MS21233	
MS	NMB
MS21233-3	ABT3
MS21233-4	ABT4
MS21233-5	ABT5
MS21233-6	ABT6
MS21233-7	ABT7
MS21233-8	ABT8
MS21233-9	ABT9
MS21233-10	ABT10
MS21233-12	ABT12
MS21233-14	ABT14
MS21233-16	ABT16



ABYT, ABYT-V

Spherical Bearings - Self-Lubricating
High Misalignment

Temperature: Operating temperature range -65° to 250°F (-54° to 121°C). Broader temperature capabilities are achievable.

Options: Bearings with CRES 17-4PH races will be designated by "H" suffix.
(Example: ABYT8VH)

Qualification: Liner approved to MIL-B-8942

MATERIALS

Part No.	Ball	Race	Liner
Catalog No.	CRES 440C AMS 5630, 55-62 HRC	CRES 410 AMS 5613, 23-35 HRC	*Teflon/Fabric Bonded to race I.D. No. Lub. Required

NMB Part Number Chamfered V-Grooved	(B) Bore Diameter		(D) Outside Diameter		(W) Ball Width		(H) Race Width		(O) Shoulder Diameter		Ball Diameter		(C) Race Chamfered × 45°		(Q) Misalign- ment	
	Inch	mm	Inch	mm	Inch	mm	Inch	mm	Inch	mm	Inch	mm	Inch	mm		
	+0.0000	+0.000	+0.0000	+0.000	+0.000	+0.00	+0.005	+0.13	+0.005	+0.13	Ref.	Ref.	Ref.	Ref.	+0.000	+0.00
ABYT3	ABYT3V	.1900	4.826	.5625	14.288	.500	12.70	0.210	5.33	.319	8.10	.437	11.10	.020	0.51	15°
ABYT4	ABYT4V	.2500	6.350	.7400	18.796	.593	15.06	0.255	6.48	.390	9.91	.593	15.06	.022	0.56	24°
ABYT5	ABYT5V	.3125	7.938	.6875	17.462	.625	15.88	0.255	6.48	.418	10.62	.593	15.06	.022	0.56	20°
ABYT6	ABYT6V	.3750	9.525	.9060	23.012	.813	20.65	0.345	8.76	.512	13.00	.781	19.84	.032	0.81	23°
ABYT7	ABYT7V	.4375	11.112	1.0000	25.400	.875	22.22	0.345	8.76	.618	15.70	.875	22.22	.032	0.81	22°
ABYT8	ABYT8V	.5000	12.700	1.1250	28.575	.937	23.80	0.401	10.19	.730	18.54	1.000	25.40	.032	0.81	20°
ABYT10	ABYT10V	.6250	15.875	1.3750	34.925	1.200	30.48	0.567	14.40	.856	21.74	1.250	31.75	.032	0.81	20°
ABYT12	ABYT12V	.7500	19.050	1.5625	39.688	1.280	32.51	0.620	15.75	.970	24.64	1.375	34.92	.044	1.12	18°
ABYT14	ABYT14V	.8750	22.225	1.7500	44.450	1.400	35.56	0.625	15.88	1.140	28.96	1.531	38.89	.044	1.12	18°
ABYT16	ABYT16V	1.0000	25.400	2.1250	53.975	1.875	47.62	0.835	21.21	1.278	32.46	1.875	47.62	.044	1.12	21°
ABYT20	ABYT20V	1.2500	31.750	2.5000	63.500	1.875	47.62	1.005	25.53	1.523	38.68	2.250	57.15	.044	1.12	21°
ABYT24	ABYT24V	1.5000	38.100	3.0000	76.200	2.250	57.15	1.175	29.84	1.800	45.72	2.672	67.87	.044	1.12	21°

* A trade name of E.I. duPont de Nemours & Co., Inc.

#The load ratings listed for this series of bearings do not take into account pin deflection. Excess pin deflection can cause a crack to traverse the ball sphere. (See page 24).

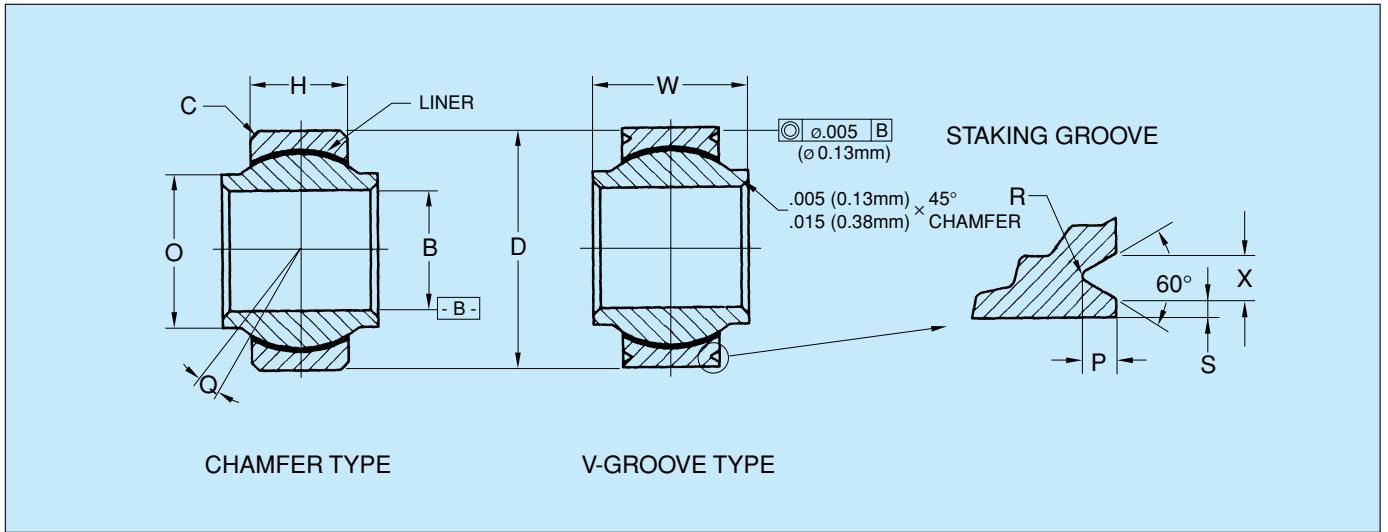

Staking Groove Data								No Load Rotational Breakaway Torque		Static Limit Load Radial		Dynamic Osc. Radial Load Axial		Approx. Weight			
(P)		(R)		(S)		(X)		In-lb	N-m	lbs	N	lbs	N	lbs	N	lbs	kg
Inch	mm	Inch	mm	Inch	mm	Inch	mm										
+0.00	+0.00	+0.00	+0.00	+0.00	+0.00	+0.00	+0.00										
-0.15	-0.38	-0.10	-0.25	-0.10	-0.25	-0.10	-0.25										
.030	0.76	.015	0.38	.020	0.51	.045	1.14	5-5.0	0.06-0.56	4100	18238	350	1557	2100	9341	.018	0.008
.030	0.76	.015	0.38	.020	0.51	.045	1.14	1.0-5.0	0.11-0.56	7100	31581	450	2002	3800	16902	.036	0.016
.030	0.76	.015	0.38	.020	0.51	.045	1.14	1.0-5.0	0.11-0.56	9000	40032	450	2002	3800	16902	.029	0.013
.030	0.76	.015	0.38	.020	0.51	.045	1.14	1.0-5.0	0.11-0.56	16000	71168	2000	8896	7200	32026	.068	0.031
.030	0.76	.015	0.38	.020	0.51	.045	1.14	1.0-5.0	0.11-0.56	19300	85846	2000	8896	8100	36029	.095	0.043
.030	0.76	.015	0.38	.020	0.51	.045	1.14	1.0-5.0	0.11-0.56	26100	116093	3200	14234	10900	48483	.159	0.072
.040	1.02	.020	0.51	.030	0.76	.055	1.40	1.0-5.0	0.11-0.56	44500	197936	7000	31136	20000	88960	.245	0.111
.060	1.52	.020	0.51	.030	0.76	.080	2.03	1.0-5.0	0.11-0.56	54800	243750	8700	38698	24200	107642	.315	0.143
.060	1.52	.020	0.51	.030	0.76	.080	2.03	2.0-8.0	0.23-0.90	65800	292678	8850	39365	27600	122765	.430	0.195
.060	1.52	.020	0.51	.030	0.76	.080	2.03	2.0-8.0	0.23-0.90	108000	480384	15900	70723	45600	202829	.831	0.377
.060	1.52	.020	0.51	.030	0.76	.080	2.03	3.0-15.0	0.34-1.70	158000	702784	23000	102304	66600	296237	1.318	0.598
.060	1.52	.020	0.51	.030	0.76	.080	2.03	3.0-15.0	0.34-1.70	220000	978560	32000	142336	93200	414554	2.223	1.008



ABG-A, ABG-VA ABG-A-501, ABG-VA-501

Spherical Bearings - Metal to Metal
Narrow AS8976

For MS to NMB part number interchangeability, see below.

Radial Clearance: .0010" to .0020"

(0.025 mm to 0.051 mm)

Axial Clearance: .010" (0.25 mm) MAX

Dimensions: All dimensions apply after plating

Concentricity: Outside diameter (D) to bore diameter (B)

Temperature: Operating temperature range -65° to 250°

Lubrication: MIL-G-21164 grease

Notes: Groove dimensions on ID of race and grease holes to ensure grease flow.

MATERIALS

Part No.		Ball	Race
ABG-A	ABG-VA	52100 STL. OR 440C/AMS 5630, 56 HRC MIN, Spherical Surface & Ends Hard Chrome Plated	4340 STL/AMS-S-5000 or AMS 6415 4130 STL/AMS-S-6758 or 8630 STL/MIL-S-6050, 27-36 HRC Cad. Plated Type I, CL. 2
ABG-A-501	ABG-VA-501		Aluminium Bronze Cad. Plated Type I, CL. 2

NMB Part Number				(B) Bore Diameter		(D) Outside Diameter		(W) Ball Width		(H) Race Width		(O) Shoulder Diameter		Ball Diameter		(Q) Misalignment		
Chamfered	V-Grooved	Chamfered	V-Grooved	Inch	mm	Inch	mm	Inch	mm	Inch	mm	Inch	mm	Inch	mm	Inch	mm	
MS21155S	MS21154S	MS21155B	MS21154B	+0.000	+0.000	+0.000	+0.000	+0.00	+0.00	+0.005	+0.13			MAX	MAX	MAX	MAX	MIN
				-0.005	-0.013	-0.005	-0.013	-0.002	-0.05	-0.005	-0.13							
ABG3A	ABG3VA	ABG3A-501	ABG3VA-501	.1900	4.826	.5625	14.288	.281	7.14	.218	5.54	.293	7.44	.438	11.13	.407	10.34	10°
ABG4A	ABG4VA	ABG4A-501	ABG4VA-501	.2500	6.350	.6562	16.667	.343	8.71	.250	6.35	.364	9.25	.501	12.73	.501	12.73	10°
ABG5A	ABG5VA	ABG5A-501	ABG5VA-501	.3125	7.938	.7500	19.050	.375	9.52	.281	7.14	.419	10.64	.594	15.09	.563	14.30	10°
ABG6A	ABG6VA	ABG6A-501	ABG6VA-501	.3750	9.525	.8125	20.638	.406	10.31	.312	7.92	.475	12.06	.657	16.69	.657	16.69	9°
ABG7A	ABG7VA	ABG7A-501	ABG7VA-501	.4375	11.112	.9062	23.017	.437	11.10	.343	8.71	.530	13.46	.719	18.26	.719	18.26	8°
ABG8A	ABG8VA	ABG8A-501	ABG8VA-501	.5000	12.700	1.0000	25.400	.500	12.70	.390	9.91	.600	15.24	.814	20.68	.814	20.68	8°
ABG9A	ABG9VA	ABG9A-501	ABG9VA-501	.5625	14.288	1.0937	27.780	.562	14.27	.437	11.10	.670	17.02	.907	23.04	.907	23.04	8°
ABG10A	ABG10VA	ABG10A-501	ABG10VA-501	.6250	15.875	1.1875	30.162	.625	15.88	.500	12.70	.739	18.77	1.001	25.43	.970	24.64	8°
ABG12A	ABG12VA	ABG12A-501	ABG12VA-501	.7500	19.050	1.4375	36.512	.750	19.05	.593	15.06	.920	23.37	1.251	31.78	1.188	30.18	8°
ABG14A	ABG14VA	ABG14A-501	ABG14VA-501	.8750	22.225	1.5625	39.688	.875	22.22	.703	17.86	.980	24.89	1.376	34.95	1.313	33.35	8°
ABG16A	ABG16VA	ABG16A-501	ABG16VA-501	1.0000	25.400	1.7500	44.450	1.000	25.40	.797	20.24	1.118	28.40	1.563	39.70	1.501	38.13	9°

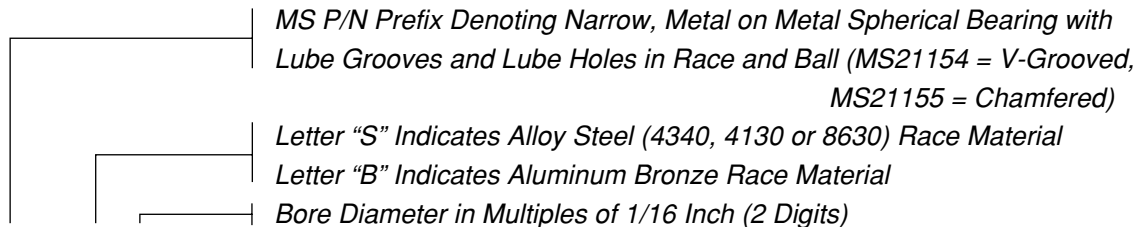

MS P/N MS21154 X X

NMB P/N ABG X V X X

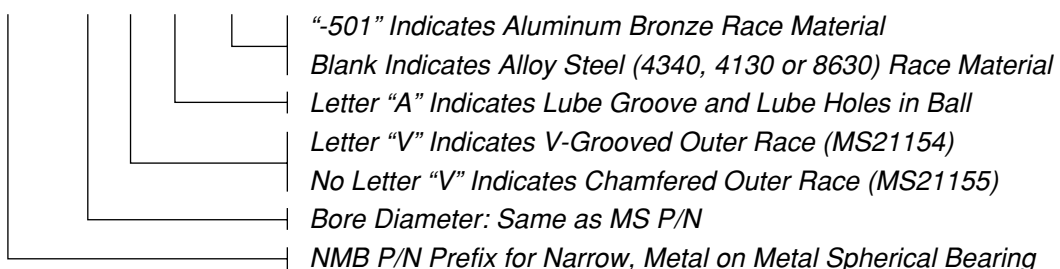

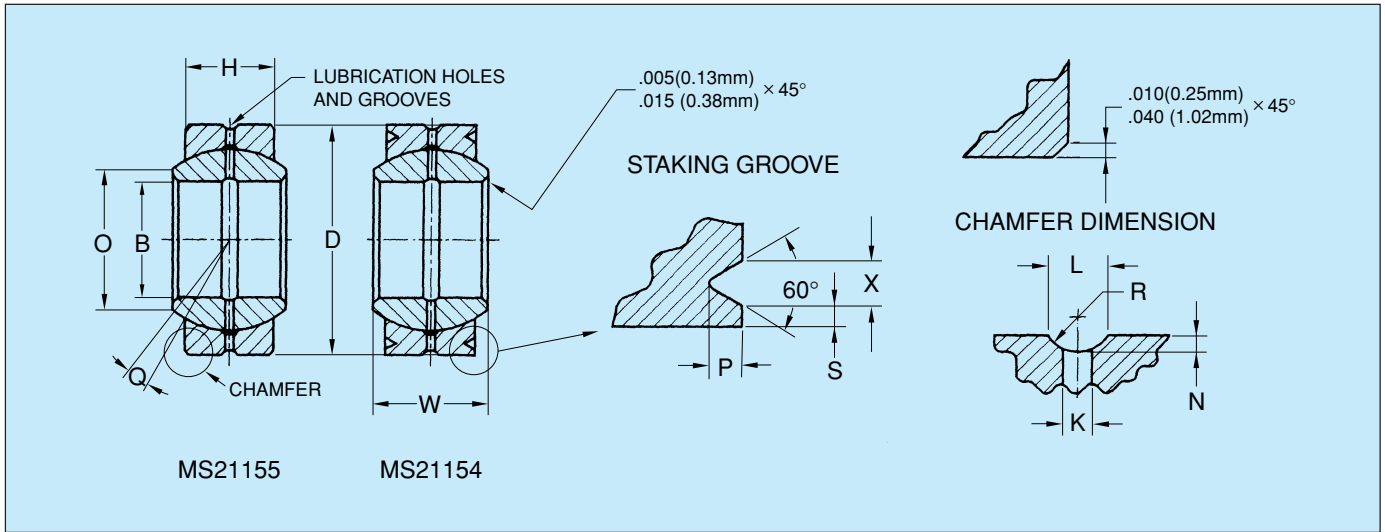

(K) Lube Hole Diameter	(L) Groove Width ID & OD of Race & ID of Ball		(R) Groove radius ID & OD of Race & ID of Ball		(N) Groove depth ID & OD of Race & ID of Ball		Staking Groove Data			Limit Static Load				Approx. Weight
							(S)	(P)	(X)	Bronze Race		Steel Race		
Inch mm	Inch mm	Inch mm	Inch mm	Inch mm	Inch mm	Inch mm	Inch mm	Inch mm	Inch mm	lbs N	lbs N	lbs N	lbs N	lbs kg
	+0.005 +0.13	-0.005 -0.13	Ref.	Ref.		+0.000 +0.00	+0.000 +0.00	+0.000 +0.00						
						-0.010 -0.25	-0.015 -0.38	-0.010 -0.25						
.047 1.19	.062 1.57	.045 1.14	.010-.015 0.25-0.38	.020 0.51	.030 0.76	.045 1.14	2800 12454	850 3781	4600 20461	2100 9341	.02 0.009			
.047 1.19	.062 1.57	.045 1.14	.010-.015 0.25-0.38	.020 0.51	.030 0.76	.045 1.14	4300 19126	1100 4893	7080 31492	2800 12454	.02 0.009			
.062 1.57	.078 1.98	.065 1.65	.010-.015 0.25-0.38	.030 0.76	.040 1.02	.055 1.40	5200 23130	1400 6227	8500 37808	3550 15790	.03 0.014			
.062 1.57	.078 1.98	.065 1.65	.010-.015 0.25-0.38	.030 0.76	.040 1.02	.055 1.40	6750 30024	1760 7828	11050 49150	4400 19571	.04 0.018			
.062 1.57	.078 1.98	.065 1.65	.010-.015 0.25-0.38	.030 0.76	.040 1.02	.055 1.40	8500 37808	2150 9563	13900 61827	5400 24019	.05 0.023			
.062 1.57	.078 1.98	.065 1.65	.010-.015 0.25-0.38	.030 0.76	.060 1.52	.080 2.03	11500 51152	2800 12454	18850 83845	7050 31358	.07 0.032			
.062 1.57	.078 1.98	.065 1.65	.010-.015 0.25-0.38	.030 0.76	.060 1.52	.080 2.03	15600 69389	3550 15790	25500 113424	8900 39587	.09 0.041			
.078 1.98	.093 2.36	.088 2.24	.010-.015 0.25-0.38	.030 0.76	.060 1.52	.080 2.03	19500 86736	4650 20683	31950 142114	11700 52042	.11 0.050			
.078 1.98	.093 2.36	.088 2.24	.010-.015 0.25-0.38	.030 0.76	.060 1.52	.080 2.03	28500 126708	6575 29246	46750 207944	16500 73392	.21 0.095			
.078 1.98	.093 2.36	.088 2.24	.010-.015 0.25-0.38	.030 0.76	.060 1.52	.080 2.03	38300 170358	9300 41366	62750 279112	23300 103638	.27 0.122			
.078 1.98	.093 2.36	.088 2.24	.010-.015 0.25-0.38	.030 0.76	.060 1.52	.080 2.03	51000 226848	12000 53376	83350 370741	30000 133440	.39 0.177			

MS21154S		MS21154B		MS21155S		MS21155B	
MS	NMB	MS	NMB	MS	NMB	MS	NMB
MS21154S03	ABG3VA	MS21154B03	ABG3VA-501	MS21155S03	ABG3A	MS21155B03	ABG3A-501
MS21154S04	ABG4VA	MS21154B04	ABG4VA-501	MS21155S04	ABG4A	MS21155B04	ABG4A-501
MS21154S05	ABG5VA	MS21154B05	ABG5VA-501	MS21155S05	ABG5A	MS21155B05	ABG5A-501
MS21154S06	ABG6VA	MS21154B06	ABG6VA-501	MS21155S06	ABG6A	MS21155B06	ABG6A-501
MS21154S07	ABG7VA	MS21154B07	ABG7VA-501	MS21155S07	ABG7A	MS21155B07	ABG7A-501
MS21154S08	ABG8VA	MS21154B08	ABG8VA-501	MS21155S08	ABG8A	MS21155B08	ABG8A-501
MS21154S09	ABG9VA	MS21154B09	ABG9VA-501	MS21155S09	ABG9A	MS21155B09	ABG9A-501
MS21154S10	ABG10VA	MS21154B10	ABG10VA-501	MS21155S10	ABG10A	MS21155B10	ABG10A-501
MS21154S12	ABG12VA	MS21154B12	ABG12VA-501	MS21155S12	ABG12A	MS21155B12	ABG12A-501
MS21154S14	ABG14VA	MS21154B14	ABG14VA-501	MS21155S14	ABG14A	MS21155B14	ABG14A-501
MS21154S16	ABG16VA	MS21154B16	ABG16VA-501	MS21155S16	ABG16A	MS21155B16	ABG16A-501



ABC-G, ABC-VG, ABC-GA, ABC-VGA

Spherical Bearings - Metal to Metal
Beryllium Copper Ball, AS81936

For MS to NMB part number interchangeability, see below.
 Radial Clearance: Free turning to .001" (0.025mm) MAX
 Axial Clearance: Free turning to .005" (0.127mm) MAX
 Concentricity: Outside diameter (D) and pitch diameter (E) to bore diameter (B) within .005" (0.13mm)
 FIM Bearings prepacked with MIL-PRF-81322
 Temperature: Operating temperature range -65° to 350°F (-54° to 177°C)

Notes: Groove dimensions on ID of race and grease holes thru race are before bearings assembly, but swaging shall not restrict grease flow.

MATERIALS

Ball	Race
BeCu/ASTM B 196, TEMPER TH04, 37 HRC MIN	CRES 17-4PH/AMS 5643, Cond. H-1150

LUBRICATION PROVISIONS

ABC-G & ABC-VG	Lubrication grooves in race and 3 equally spaced holes through race only.
ABC-GA ABC-VGA	Lubrication grooves in race and bore of ball and 3 equally spaced holes through race and ball.

NMB Part Number				(B) Bore Diameter		(D) Outside Diameter		(W) Ball Width		(H) Race Width		(O) Shoulder Diameter		Ball Diameter		(Q) Misalignment
Chamfered	V-Grooved	Chamfered	V-Grooved	Inch	mm	Inch	mm	Inch	mm	Inch	mm	Inch	mm	Inch	mm	MIN
				+0.000	+0.000	+0.000	+0.000	+0.00	+0.00	+0.00	+0.00	MIN	MIN	MAX	MAX	MIN
M81936/2-R	M81936/1-R	M81936/2-	M81936/1-	-0.005	-0.013	-0.005	-0.013	-0.005	-0.13	-0.005	-0.13	MIN	MIN	MAX	MAX	MIN
ABC4G	ABC4VG	ABC4GA	ABC4VGA	.2500	6.350	.6562	16.667	.343	8.71	.250	6.35	.357	9.53	.501	12.73	12°
ABC5G	ABC5VG	ABC5GA	ABC5VGA	.3125	7.938	.7500	19.050	.375	9.52	.281	7.14	.413	10.49	.563	14.30	11°
ABC6G	ABC6VG	ABC6GA	ABC6VGA	.3750	9.525	.8125	20.638	.406	10.31	.312	7.92	.509	12.93	.657	16.69	9°
ABC7G	ABC7VG	ABC7GA	ABC7VGA	.4375	11.112	.9062	23.017	.437	11.10	.343	8.71	.563	14.30	.719	18.26	8°
ABC8G	ABC8VG	ABC8GA	ABC8VGA	.5000	12.700	1.0000	25.400	.500	12.70	.390	9.91	.634	16.10	.814	20.68	8°
ABC9G	ABC9VG	ABC9GA	ABC9VGA	.5625	14.288	1.0937	27.780	.562	14.27	.437	11.10	.664	16.87	.876	22.25	8°
ABC10G	ABC10VG	ABC10GA	ABC10VGA	.6250	15.875	1.1875	30.162	.625	15.88	.500	12.70	.732	18.59	.969	24.61	8°
ABC12G	ABC12VG	ABC12GA	ABC12VGA	.7500	19.050	1.4375	36.512	.750	19.05	.593	15.06	.913	23.19	1.188	30.18	8°
ABC13G	ABC13VG	ABC13GA	ABC13VGA	.8125	20.638	1.5625	39.688	.812	20.62	.650	16.51	.984	24.99	1.282	32.56	8°
ABC14G	ABC14VG	ABC14GA	ABC14VGA	.8750	22.225	1.6562	42.067	.875	22.22	.703	17.86	1.054	26.77	1.376	34.95	8°
ABC16G	ABC16VG	ABC16GA	ABC16VGA	1.0000	25.400	1.8750	47.625	1.000	25.40	.797	20.24	1.193	30.30	1.563	39.70	8°
ABC18G	ABC18VG	ABC18GA	ABC18VGA	1.1250	28.575	2.1250	53.975	1.125	28.58	.900	22.86	1.334	33.88	1.751	44.48	8°
ABC20G	ABC20VG	ABC20GA	ABC20VGA	1.2500	31.750	2.3125	58.738	1.250	31.75	1.000	25.40	1.473	37.41	1.938	49.23	8°
ABC22G	ABC22VG	ABC22GA	ABC22VGA	1.3750	34.925	2.5625	65.088	1.375	34.92	1.100	27.94	1.654	42.01	2.157	54.79	8°
ABC24G	ABC24VG	ABC24GA	ABC24VGA	1.5000	38.100	2.8125	71.438	1.500	38.10	1.200	30.48	1.794	45.57	2.345	59.56	8°

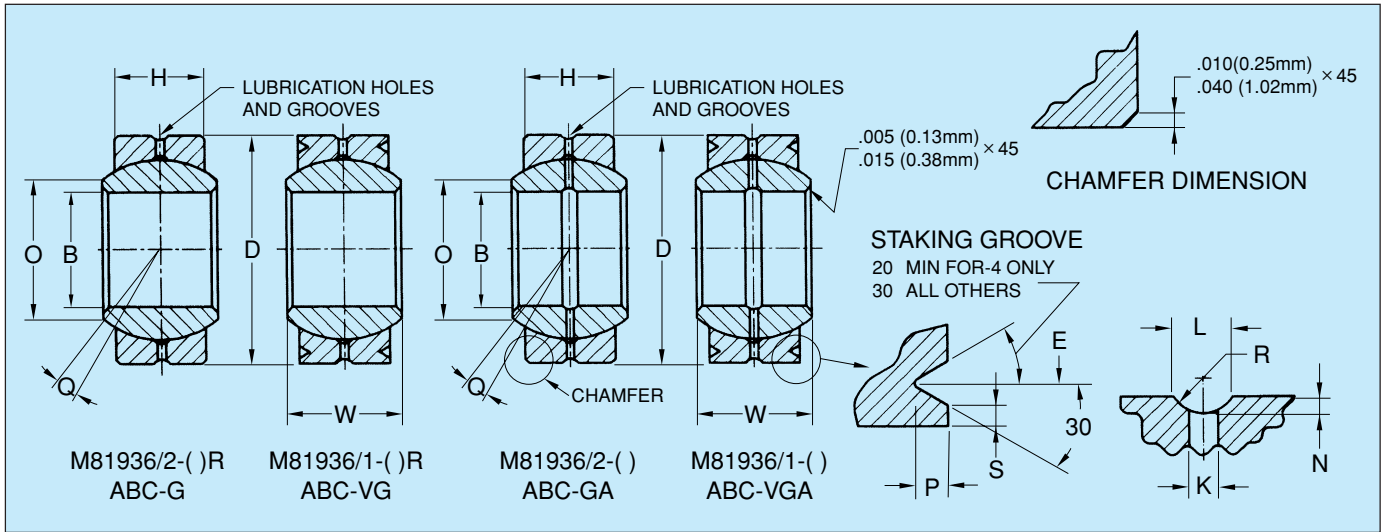

(K) Lube Hole Diameter		(L) Groove Width ID & OD of Race & ID of Ball		(R) Groove radius ID & OD of Race & ID of Ball		(N) Groove depth ID & OD of Race & ID of Ball		Staking Groove Data (E) Pitch Diameter (S) (P)						Static Limit Load Radial Axial		Approx. Weight					
Inch	mm	Inch	mm	Inch	mm	Inch	mm	Inch	mm	Inch	mm	Inch	mm	Inch	mm	lbs	N	lbs	N	lbs	kg
								+0.00	+0.00	+0.00	+0.00	+0.00	+0.00								
								-0.10	-0.25	-0.10	-0.25	-0.15	-0.38								
.032-.062	0.81-1.57	.042-.078	1.07-1.98	.030-.062	0.76-1.57	.010-.015	0.25-0.38	.596	15.14	.020	0.51	.030	0.76	6330	28156	1930	8585	.02	0.009		
.042-.062	1.07-1.57	.042-.078	1.07-1.98	.030-.062	0.76-1.57	.010-.015	0.25-0.38	.652	16.56	.030	0.76	.040	1.02	8460	37630	2450	10898	.03	0.014		
.042-.062	1.07-1.57	.042-.078	1.07-1.98	.030-.062	0.76-1.57	.010-.015	0.25-0.38	.714	18.14	.030	0.76	.040	1.02	11400	50707	3090	13744	.04	0.018		
.052-.062	1.32-1.57	.065-.094	1.65-2.39	.060-.094	1.52-2.39	.010-.015	0.25-0.38	.808	20.52	.030	0.76	.040	1.02	14800	65830	3740	16636	.05	0.023		
.052-.062	1.32-1.57	.065-.094	1.65-2.39	.060-.094	1.52-2.39	.010-.015	0.25-0.38	.878	22.30	.030	0.76	.060	1.52	20400	90739	4860	21617	.07	0.032		
.052-.062	1.32-1.57	.065-.094	1.65-2.39	.060-.094	1.52-2.39	.010-.015	0.25-0.38	.972	24.69	.030	0.76	.060	1.52	26700	118762	6100	27133	.09	0.041		
.062-.078	1.57-1.98	.073-.109	1.85-2.77	.070-.125	1.78-3.18	.010-.015	0.25-0.38	1.065	27.05	.030	0.76	.060	1.52	33100	147229	8080	35940	.11	0.050		
.062-.078	1.57-1.98	.073-.109	1.85-2.77	.070-.125	1.78-3.18	.010-.015	0.25-0.38	1.315	33.40	.030	0.76	.060	1.52	50000	222400	11440	50885	.21	0.095		
.062-.078	1.57-1.98	.073-.109	1.85-2.77	.070-.125	1.78-3.18	.010-.015	0.25-0.38	1.440	36.58	.030	0.76	.060	1.52	59000	262432	13800	61382	.24	0.109		
.062-.078	1.57-1.98	.073-.109	1.85-2.77	.070-.125	1.78-3.18	.010-.015	0.25-0.38	1.534	38.96	.030	0.76	.060	1.52	70300	312694	16160	71880	.27	0.122		
.078-.093	1.98-2.36	.082-.109	2.08-2.77	.090-.125	2.29-3.18	.010-.015	0.25-0.38	1.753	44.53	.030	0.76	.060	1.52	77700	345600	20850	92741	.39	0.177		
.078-.093	1.98-2.36	.082-.109	2.08-2.77	.090-.125	2.29-3.18	.010-.015	0.25-0.38	2.003	50.88	.030	0.76	.060	1.52	121500	540432	26740	118940	.72	0.327		
.078-.093	1.98-2.36	.082-.109	2.08-2.77	.090-.125	2.29-3.18	.010-.015	0.25-0.38	2.190	55.63	.030	0.76	.060	1.52	152000	676096	33065	147073	.93	0.422		
.078-.093	1.98-2.36	.082-.109	2.08-2.77	.090-.125	2.29-3.18	.010-.015	0.25-0.38	2.440	61.98	.030	0.76	.060	1.52	186000	827328	40120	178454	1.28	0.581		
.078-.093	1.98-2.36	.082-.109	2.08-2.77	.090-.125	2.29-3.18	.010-.015	0.25-0.38	2.690	68.33	.030	0.76	.060	1.52	224000	996352	47820	212703	1.67	0.757		



MS to NMB Part Numbers

Spherical Bearings AS81936

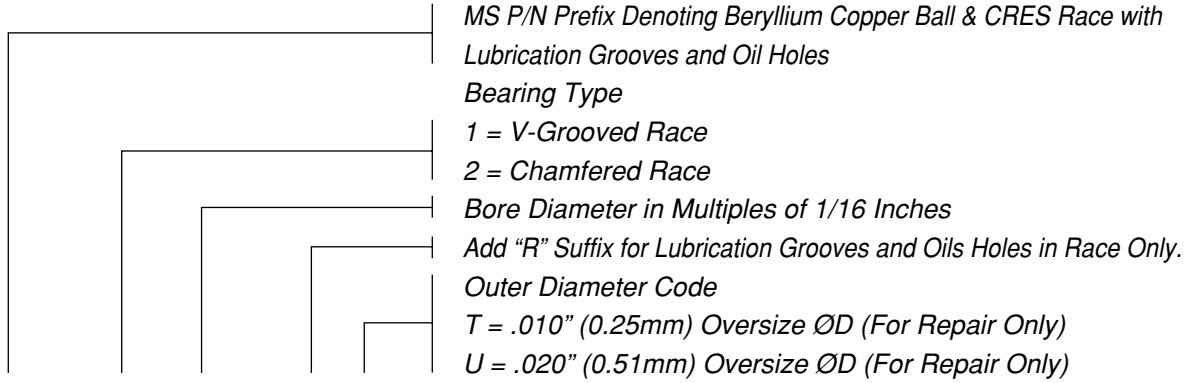

MS P/N M81936/1 - X R X

NMB P/N ABC X V G A X

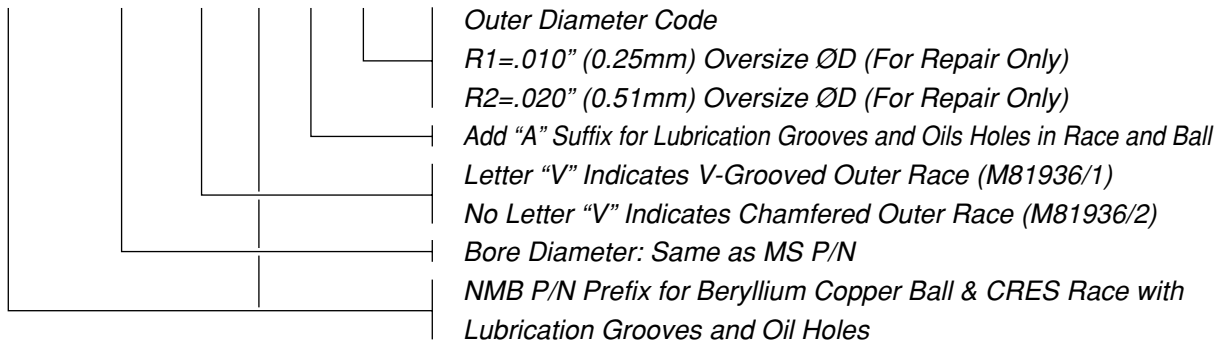

M81936/1		M81936/2		M81936/1-R		M81936/2-R	
MS	NMB	MS	NMB	MS	NMB	MS	NMB
M81936/1-4	ABC4VGA	M81936/2-4	ABC4GA	M81936/1-4R	ABC4VG	M81936/2-4R	ABC4G
M81936/1-5	ABC5VGA	M81936/2-5	ABC5GA	M81936/1-5R	ABC5VG	M81936/2-5R	ABC5G
M81936/1-6	ABC6VGA	M81936/2-6	ABC6GA	M81936/1-6R	ABC6VG	M81936/2-6R	ABC6G
M81936/1-7	ABC7VGA	M81936/2-7	ABC7GA	M81936/1-7R	ABC7VG	M81936/2-7R	ABC7G
M81936/1-8	ABC8VGA	M81936/2-8	ABC8GA	M81936/1-8R	ABC8VG	M81936/2-8R	ABC8G
M81936/1-9	ABC9VGA	M81936/2-9	ABC9GA	M81936/1-9R	ABC9VG	M81936/2-9R	ABC9G
M81936/1-10	ABC10VGA	M81936/2-10	ABC10GA	M81936/1-10R	ABC10VG	M81936/2-10R	ABC10G
M81936/1-12	ABC12VGA	M81936/2-12	ABC12GA	M81936/1-12R	ABC12VG	M81936/2-12R	ABC12G
M81936/1-13	ABC13VGA	M81936/2-13	ABC13GA	M81936/1-13R	ABC13VG	M81936/2-13R	ABC13G
M81936/1-14	ABC14VGA	M81936/2-14	ABC14GA	M81936/1-14R	ABC14VG	M81936/2-14R	ABC14G
M81936/1-16	ABC16VGA	M81936/2-16	ABC16GA	M81936/1-16R	ABC16VG	M81936/2-16R	ABC16G
M81936/1-18	ABC18VGA	M81936/2-18	ABC18GA	M81936/1-18R	ABC18VG	M81936/2-18R	ABC18G
M81936/1-20	ABC20VGA	M81936/2-20	ABC20GA	M81936/1-20R	ABC20VG	M81936/2-20R	ABC20G
M81936/1-22	ABC22VGA	M81936/2-22	ABC22GA	M81936/1-22R	ABC22VG	M81936/2-22R	ABC22G
M81936/1-24	ABC24VGA	M81936/2-24	ABC24GA	M81936/1-24R	ABC24VG	M81936/2-24R	ABC24G

OVERSIZE BEARING DIMENSIONS (OUTSIDE DIAMETER)**M81936/1 & M81936/2**

DASH No	Nominal Bore Size	1st Oversize (.010) ØD	2nd Oversize (.020) ØD
-4	.2500 (6.350mm)	.6662 (16.921mm)	.6762 (17.175mm)
-5	.3125 (7.938mm)	.7600 (19.304mm)	.7700 (19.558mm)
-6	.3750 (9.525mm)	.8225 (20.892mm)	.8325 (21.146mm)
-7	.4375 (11.112mm)	.9162 (23.271mm)	.9262 (23.525mm)
-8	.5000 (12.700mm)	1.0100 (25.654mm)	1.0200 (25.908mm)
-9	.5625 (14.288mm)	1.1037 (28.034mm)	1.1137 (28.288mm)
-10	.6250 (15.875mm)	1.1975 (30.416mm)	1.2075 (30.670mm)
-12	.7500 (19.050mm)	1.4475 (36.766mm)	1.4575 (37.020mm)
-13	.8125 (20.638mm)	1.5725 (39.942mm)	1.5825 (40.196mm)
-14	.8750 (22.225mm)	1.6662 (42.321mm)	1.6762 (42.575mm)
-16	1.0000 (25.400mm)	1.8850 (47.879mm)	1.8950 (48.133mm)
-18	1.1250 (28.575mm)	2.1350 (54.229mm)	2.1450 (54.483mm)
-20	1.2500 (31.750mm)	2.2000 (55.880mm)	2.2100 (56.134mm)
-22	1.3750 (34.925mm)	2.5725 (65.342mm)	2.5825 (65.596mm)
-24	1.5000 (38.100mm)	2.8225 (71.692mm)	2.8325 (71.946mm)



ABG, ABG-V, HABG, HABG-V ABK, ABK-V, HABK, HABK-V

Spherical Bearings - Metal to Metal

Radial Clearance: Free running to .002" (0.051mm) MAX

Plating: When specified in material block, ball spherical diameter and ends are hard Chrome plated per AMS-QQ-C-320. All external surfaces of race are Cadmium plated per AMS-QQ-P-416. HABK-501 & HABK-V-501 series only furnished without Cadmium plates as standard items. To specify Cadmium plate on these series only, add suffix "C" to part no.

Dimensions: ABG, ABG-V, ABK, ABK-V series dimensions apply AFTER plating. HABG, HABG-V, HABK, HABK-V series dimensions apply before plating.

Concentricity: Bore Diameter "B" to outside diameter "D" within .005" (0.13mm) FIM.

Options: \triangle Part No. designation as shown furnished with 410 stainless steel race material. To specify 17-4PH stainless steel, add suffix "H" to designation. Examples: ABK8VCRPLH, HABG8CRPLH.

- For lubrication holes & grooves, see OPTIONAL LUBRICATION PROVISIONS
- For dry film lubrication, add suffixes to the designation as follows:
-1 = dry film on race ID. -2 = dry film on ball bore
-3 = dry film on ball spherical surface.

These suffixes are used singly or in combination. Example: ABG3-1, ABK4VG-13, HABK10V-123.
Dimensions apply before dry film.

MATERIALS

Part No.	Ball	Race
Catalog No.	52100 STL, Heat Treated & Chrome Plated	4130 STL Heat Treated & Cad. Plated
Catalog No. + SS	52100 STL, Heat Treated & Chrome Plated	CRES 410 Heat Treated \triangle
Catalog No. + CR	CRES 440C Heat Treated	CRES 410 Heat Treated \triangle
Catalog No. + CRPL	CRES 440C Heat Treated & Chrome Plated	CRES 410 Heat Treated \triangle
Catalog No. + 501	52100 STL, Heat Treated & Chrome Plated	Aluminum Bronze Cad. Plated

Notes: 1. Load ratings are based on bearings with lube grooves and lube holes.
2. The ABG-A and ABG-VA basic and -501 series bearings can also be furnished to MIL-B-8976 procurement specification. Please see page 42 and 43.
3. Staking grooves not available on ABG2 series bearings.

NMB Part Number				(B) Bore Diameter		(D) Outside Diameter		(W) Ball Width		(H) Race Width		(O) Shoulder Diameter		Ball Diameter		(Q) Misalignment
				Inch	mm	Inch	mm	Inch	mm	Inch	mm	Inch	mm	Inch	mm	
				+0.000	+0.000	+0.000	+0.000	+0.00	+0.00	+0.005	+0.13					
				-0.005	-0.013	-0.005	-0.013	-0.02	-0.05	-0.005	-0.13	Ref.	Ref.	Ref.	Ref.	MIN
ABG2	HABG2	ABK2	HABK2	.1650	4.191	.4687	11.905	.250	6.35	.187	4.75	.235	5.97	.344	8.74	13°
ABG3	HABG3	ABK3	HABK3	.1900	4.826	.5625	14.288	.281	7.14	.218	5.54	.293	7.44	.406	10.31	11°
ABG3V	HABG3V	ABK3V	HABK3V													
ABG4	HABG4	ABK4	HABK4	.2500	6.350	.6562	16.667	.343	8.71	.250	6.35	.364	9.25	.500	12.70	13°
ABG4V	HABG4V	ABK4V	HABK4V													
ABG5	HABG5	ABK5	HABK5	.3125	7.938	.7500	19.050	.375	9.52	.281	7.14	.419	10.64	.562	14.27	11°
ABG5V	HABG5V	ABK5V	HABK5V													
ABG6	HABG6	ABK6	HABK6	.3750	9.525	.8125	20.638	.406	10.31	.312	7.92	.515	13.08	.656	16.66	10°
ABG6V	HABG6V	ABK6V	HABK6V													
ABG7	HABG7	ABK7	HABK7	.4375	11.112	.9062	23.017	.437	11.10	.343	8.71	.570	14.48	.718	18.24	9°
ABG7V	HABG7V	ABK7V	HABK7V													
ABG8	HABG8	ABK8	HABK8	.5000	12.700	1.0000	25.400	.500	12.70	.390	9.91	.641	16.28	.813	20.65	9°
ABG8V	HABG8V	ABK8V	HABK8V													
ABG9	HABG9	ABK9	HABK9	.5625	14.288	1.0937	27.780	.562	14.27	.437	11.10	.711	18.06	.906	23.01	9°
ABG9V	HABG9V	ABK9V	HABK9V													
ABG10	HABG10	ABK10	HABK10	.6250	15.875	1.1875	30.162	.625	15.88	.500	12.70	.739	18.77	.968	24.59	9°
ABG10V	HABG10V	ABK10V	HABK10V													
ABG12	HABG12	ABK12	HABK12	.7500	19.050	1.4375	36.512	.750	19.05	.593	15.06	.920	23.37	1.187	30.15	9°
ABG12V	HABG12V	ABK12V	HABK12V													
ABG14	HABG14	ABK14	HABK14	.8750	22.225	1.5625	39.688	.875	22.22	.703	17.86	.978	24.84	1.312	33.32	9°
ABG14V	HABG14V	ABK14V	HABK14V													
ABG16	HABG16	ABK16	HABK16	1.0000	25.400	1.7500	44.450	1.000	25.40	.797	20.24	1.118	28.40	1.500	38.10	10°
ABG16V	HABG16V	ABK16V	HABK16V													

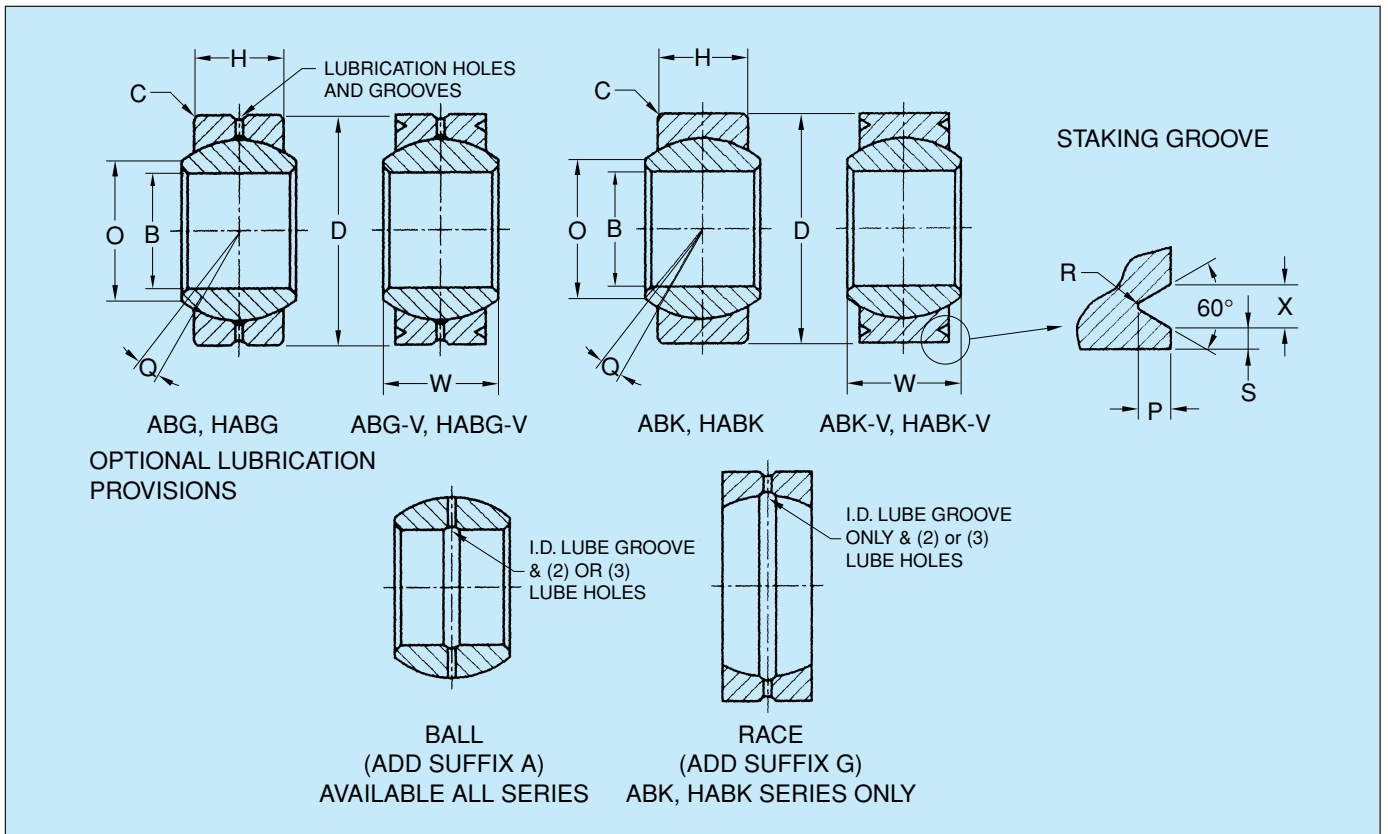

(C) Race Chamfered $\times 45^\circ$		Staking Groove Data								Limit Static Radial Load				Approx. Weight	
		(P)		(R)		(S)		(X)		Bronze Race		Steel Race			
Inch	mm	Inch	mm	Inch	mm	Inch	mm	Inch	mm	lbs	N	lbs	N	lbs	kg
+0.00	+0.00	+0.00	+0.00	+0.00	+0.00	+0.00	+0.00	+0.00	+0.00						
-.010	-.025	-.015	-.038	-.010	-.025	-.010	-.025	-.010	-.025						
.020	0.51	N/A	N/A	N/A	N/A	N/A	N/A	N/A	N/A	1800	8006	2970	13211	.01	0.005
.020	0.51	.030	0.76	.015	0.38	.020	0.51	.045	1.14	2800	12454	4600	20461	.02	0.009
.022	0.56	.030	0.76	.015	0.38	.020	0.51	.045	1.14	4300	19126	7080	31492	.02	0.009
.032	0.81	.040	1.02	.020	0.51	.030	0.76	.055	1.40	5200	23130	8500	37808	.03	0.014
.032	0.81	.040	1.02	.020	0.51	.030	0.76	.055	1.40	6750	30024	11050	49150	.04	0.019
.032	0.81	.040	1.02	.020	0.51	.030	0.76	.055	1.40	8500	37808	13900	61827	.05	0.023
.032	0.81	.060	1.52	.020	0.51	.030	0.76	.080	2.03	11500	51152	18850	83845	.07	0.032
.032	0.81	.060	1.52	.020	0.51	.030	0.76	.080	2.03	15600	69389	25500	113424	.09	0.041
.032	0.81	.060	1.52	.020	0.51	.030	0.76	.080	2.03	19500	86736	31950	142114	.11	0.050
.040	1.02	.060	1.52	.020	0.51	.030	0.76	.080	2.03	28500	126768	46750	207944	.21	0.096
.040	1.02	.060	1.52	.020	0.51	.030	0.76	.080	2.03	38300	170358	62750	279112	.27	0.123
.040	1.02	.060	1.52	.020	0.51	.030	0.76	.080	2.03	51000	226848	83350	370741	.39	0.177



ABW, ABW-V

Spherical Bearings - Metal to Metal Wide

Radial Clearance: Free running to .002" (0.051mm) MAX

Plating: When specified in materials block, ball spherical diameter and ends are Chrome plated per AMS-QQ-C-320. Class 2. All external surfaces of race are Cadmium plated per AMS-QQ-P-416.

Dimensions: All dimensions apply after plating.

Options: \triangle Part No. designation as shown furnished with 410 stainless steel race material. To specify 17-4PH stainless steel, add suffix "H" to designation. Example: ABW8VCRPLH.

2. For lubrication holes & grooves, see Optional Lubrication Provisions

3. For dry film lubrication, add suffixes to the designation as follows:

-1 = dry film on race ID.

-2 = dry film on ball bore

-3 = dry film on ball spherical surface.

These suffixes are used singly or in combination.

Example: ABW4-1, ABW8VG-13, ABW10-501-123

Dimensions apply before dry film lubrication.

Notes: Groove dimensions on ID of race and grease holes thru race are before bearing assembly, but swaging shall not restrict grease flow. Load ratings are based on bearings without lube grooves and lube holes.

MATERIALS

Part No.	Ball	Race
Catalog No.	52100 STL, Heat Treated & Hard Chrome Plated	4130 STL Heat Treated & Cad. Plated
Catalog No. + SS	52100 STL, Heat Treated & Hard Chrome Plated	CRES 410 Heat Treated \triangle
Catalog No. + CR	CRES 440C Heat Treated	CRES 410 Heat Treated \triangle
Catalog No. + CRPL	CRES 440C Heat Treated & Chrome Plated	CRES 410 Heat Treated \triangle
Catalog No. + 501	52100 STL, Heat Treated & Chrome Plated	Aluminum Bronze Cad. Plated

NMB Part Number		(B) Bore Diameter		(D) Outside Diameter		(W) Ball Width		(H) Race Width		(O) Shoulder Diameter		(C) Race Chamfered x 45°			
Chamfered	V-Grooved	Inch	mm	Inch	mm	Inch	mm	Inch	mm	Inch	mm	Inch	mm		
		+0.000	+0.000	+0.000	+0.000	+0.000	+0.000	+0.005	+0.13	Ref.	Ref.	+0.015	+0.38		
		-0.005	-0.013	-0.005	-0.013	-0.005	-0.13	-0.005	-0.13	Ref.	Ref.	Ref.	Ref.		
ABW3	ABW3V	.1900	4.826	.6250	15.875	.437	11.10	.327	8.31	.301	7.65	.531	13.49	.010	0.25
ABW3-10	ABW3-10V	.1900	4.826	.5000	12.700	.359	9.12	.286	7.26	.249	6.32	.437	11.10	.010	0.25
ABW4	ABW4V	.2500	6.350	.6250	15.875	.437	11.10	.327	8.31	.301	7.65	.531	13.49	.010	0.25
ABW5	ABW5V	.3125	7.938	.6875	17.462	.437	11.10	.317	8.05	.401	10.19	.593	15.06	.010	0.25
ABW6	ABW6V	.3750	9.525	.8125	20.638	.500	12.70	.406	10.31	.471	11.96	.687	17.45	.010	0.25
ABW7	ABW7V	.4375	11.112	.9375	23.812	.562	14.27	.442	11.23	.542	13.77	.781	19.84	.010	0.25
ABW8	ABW8V	.5000	12.700	1.0000	25.400	.625	15.87	.505	12.83	.612	15.54	.875	22.22	.020	0.51
ABW9	ABW9V	.5625	14.288	1.1250	28.575	.687	17.45	.536	13.61	.726	18.44	1.000	25.40	.020	0.51
ABW10	ABW10V	.6250	15.875	1.1875	30.162	.750	19.05	.567	14.40	.752	19.10	1.062	26.97	.020	0.51
ABW12	ABW12V	.7500	19.050	1.3750	34.925	.875	22.22	.630	16.00	.892	22.66	1.250	31.75	.020	0.51
ABW14	ABW14V	.8750	22.225	1.6250	41.275	.875	22.22	.755	19.18	1.061	26.95	1.375	34.92	.020	0.51
ABW16	ABW16V	1.0000	25.400	2.1250	53.975	1.375	34.92	1.005	25.53	1.275	32.38	1.875	47.62	.020	0.51
ABW20	ABW20V	1.2500	31.750	2.3750	60.325	1.500	38.10	1.130	28.70	1.460	37.08	2.093	53.16	.020	0.51
ABW20-10	ABW20-10V	1.2500	31.750	2.0000	50.800	1.093	27.76	.942	23.93	1.406	35.71	1.781	45.24	.020	0.51
ABW22	ABW22V	1.3750	34.925	2.5625	65.088	1.687	42.85	1.223	31.06	1.535	38.99	2.281	57.94	.020	0.51
ABW24	ABW24V	1.5000	38.100	2.6875	68.262	1.687	42.85	1.223	31.06	1.693	43.00	2.390	60.71	.030	0.76
ABW28	ABW28V	1.7500--	44.450	3.0000--	76.200	1.812	46.02	1.317	33.45	1.964	49.89	2.672	67.87	.030	0.76
ABW32	ABW32V	2.0000--	50.800	3.2500--	82.550	1.937	49.20	1.380	35.05	2.208	56.08	2.937	74.60	.030	0.76
ABW36	ABW36V	2.2500--	57.150	3.6250--	92.075	2.000	50.80	1.411	35.84	2.442	62.03	3.156	80.16	.030	0.76
ABW40	ABW40V	2.5000--	63.500	3.9375---	100.012	2.062	52.37	1.442	36.63	2.750	69.85	3.437	87.30	.030	0.76
ABW44	ABW44V	2.7500--	69.850	4.1250---	104.775	2.187	55.55	1.505	38.23	2.968	75.39	3.687	93.65	.030	0.76
ABW48	ABW48V	3.0000--	76.200	4.3750---	111.125	2.312	58.72	1.567	39.80	3.187	80.95	4.000	101.60	.030	0.76

- Tolerance : -.0000-.0008 (+0.000-0.020 mm)
 -- Tolerance : +.0000-.0010 (+0.000-0.025mm)
 --- Tolerance : +.0000-.0013 (+0.000 ~ -0.033mm)

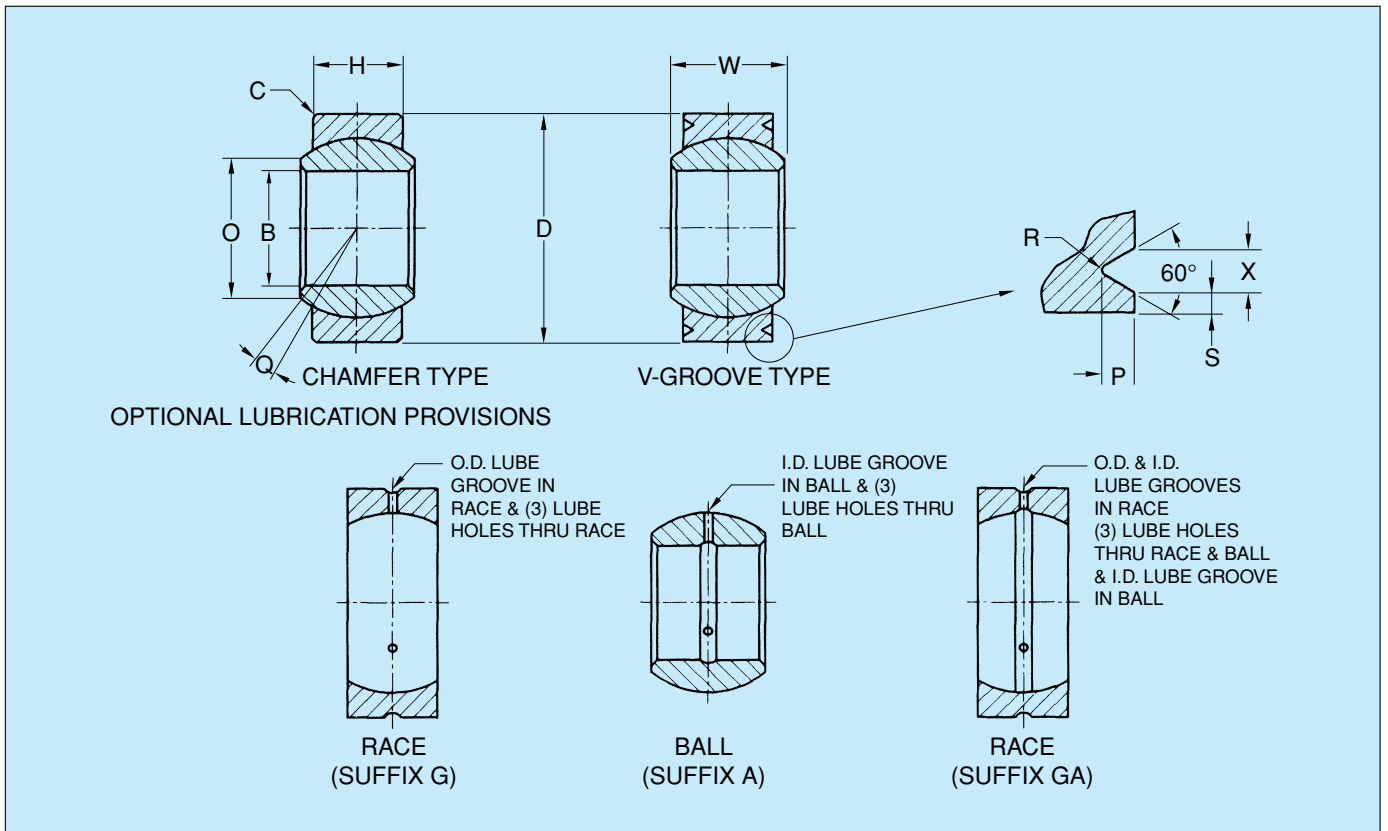

(Q) Misalign- ment	Staking Groove Data								Limit Static Radial Load				Approx. Weight	
	(P)		(R)		(S)		(X)		Bronze Race		Steel Race		lbs	kg
	Inch	mm	Inch	mm	Inch	mm	Inch	mm	lbs	N	lbs	N		
	+0.00	+0.00	+0.00	+0.00	+0.00	+0.00	+0.00	+0.00						
Ref.	-.015	-0.38	-.010	-0.25	-.010	-0.25	-.010	-0.25						
17°	.030	0.76	.015	0.38	.020	0.51	.045	1.14	4100	18237	4100	18237	.031	0.014
14°	.030	0.76	.015	0.38	.020	0.51	.045	1.14	4100	18237	4100	18237	.015	0.007
17°	.030	0.76	.015	0.38	.020	0.51	.045	1.14	7100	31581	7100	31581	.031	0.014
15°	.030	0.76	.015	0.38	.020	0.51	.045	1.14	8800	39142	11100	49373	.035	0.016
11°	.040	1.02	.020	0.51	.030	0.76	.055	1.40	13000	57824	16000	71168	.060	0.028
12°	.040	1.02	.020	0.51	.030	0.76	.055	1.40	16300	72502	21750	96744	.080	0.037
10°	.040	1.02	.020	0.51	.030	0.76	.055	1.40	21200	94298	28400	126323	.100	0.046
11°	.040	1.02	.020	0.51	.030	0.76	.055	1.40	25800	114758	36000	160128	.135	0.062
12°	.040	1.02	.020	0.51	.030	0.76	.055	1.40	29000	128992	44500	197936	.160	0.073
14°	.060	1.52	.020	0.51	.030	0.76	.080	2.03	38400	170803	62800	279334	.240	0.109
6°	.060	1.52	.020	0.51	.030	0.76	.080	2.03	50000	222400	81900	364291	.350	0.159
15°	.060	1.52	.020	0.51	.030	0.76	.080	2.03	93000	413664	114000	507072	.970	0.440
13°	.060	1.52	.020	0.51	.030	0.76	.080	2.03	117500	522640	178000	791744	1.120	0.508
6°	.060	1.52	.020	0.51	.030	0.76	.080	2.03	82000	364736	134000	596032	.564	0.256
15°	.060	1.52	.020	0.51	.030	0.76	.080	2.03	114000	507072	215500	958544	1.390	0.632
14°	.060	1.52	.020	0.51	.030	0.76	.080	2.03	119000	529312	239000	1063072	1.480	0.672
13°	.060	1.52	.020	0.51	.030	0.76	.080	2.03	140000	622720	282000	1254336	1.910	0.867
13°	.060	1.52	.020	0.51	.030	0.76	.080	2.03	163000	725024	326000	1450048	2.220	1.007
13°	.060	1.52	.020	0.51	.030	0.76	.080	2.03	179000	796192	358000	1592384	2.780	1.261
12°	.060	1.52	.020	0.51	.030	0.76	.080	2.03	200000	889600	400000	1779200	3.280	1.488
12°	.060	1.52	.020	0.51	.030	0.76	.080	2.03	224000	996352	449000	1997152	3.550	1.611
12°	.060	1.52	.020	0.51	.030	0.76	.080	2.03	250000	1112000	500000	2224000	4.000	1.815



ABY, ABY-V

Spherical Bearings - Metal to Metal
High Misalignment

Radial Clearance: Free running to .002" (0.051mm) MAX

Plating: When specified in materials block, ball spherical diameter and ends are Chrome plated per AMS-QQ-C-320. All external surfaces of race are Cadmium plated per AMS-QQ-P-416.

Dimensions: ABY, ABY-V series dimensions apply after plating.
Concentricity: Bore Diameter "B" to outside diameter "D" within .005" (0.13mm) FIM.

Options: \triangle Part No. designation as shown furnished with 410 stainless steel race material. To specify 17-4PH stainless steel, add suffix "H" to designation. Example: ABY12CRH.
2. For lubrication holes & grooves, see OPTIONAL LUBRICATION PROVISIONS (Example: ABY8G, ABY10VCRGA, ABY4G-501)
3. For dry film lubrication, add suffixes to the designation as follows:
-1 = dry film on race ID.
-2 = dry film on ball bore
-3 = dry film on ball spherical surface.

These suffixes are used singly or in combination. Example: ABY8-1, ABY4V-13, ABY10VCR-123.

Dimensions apply before dry film.

Notes: Load ratings are based on bearings without lubrication grooves.

MATERIALS

Part No.	Ball	Race
Catalog No.	52100 STL, Heat Treated & Chrome Plated	CRES 410 Heat Treated \triangle
Catalog No. + S	52100 STL, Heat Treated & Chrome Plated	4130 STL Heat Treated & Cad. Plated
Catalog No. + CR	CRES 440C Heat Treated	CRES 410 Heat Treated \triangle
Catalog No. + CRPL	CRES 440C Heat Treated & Chrome Plated	CRES 410 Heat Treated \triangle
Catalog No. + 501	52100 STL, Heat Treated & Chrome Plated	Aluminum Bronze Cad. Plated

NMB Part Number Chamfered V-Grooved	(B) Bore Diameter		(D) Outside Diameter		(W) Ball Width		(H) Race Width		(O) Shoulder Diameter		Ball Diameter		(C) Race Chamfered $\times 45^\circ$	
	Inch	mm	Inch	mm	Inch	mm	Inch	mm	Inch	mm	Inch	mm	Inch	mm
	+0.000	+0.000	+0.000	+0.000	+0.000	+0.000	+0.005	+0.13					+0.000	+0.000
	-0.005	-0.013	-0.005	-0.013	-0.005	-0.13	-0.005	-0.13	Ref.	Ref.	Ref.	Ref.	-0.010	-0.25
ABY3 ABY3V	.1900	4.826	.5625	14.288	.500	12.70	.210	5.33	.319	8.10	.437	11.10	.020	0.51
ABY4 ABY4V	.2500	6.350	.7400	18.796	.593	15.06	.255	6.48	.390	9.91	.593	15.06	.022	0.56
ABY5 ABY5V	.3125	7.938	.6875	17.462	.625	15.88	.255	6.48	.418	10.62	.593	15.06	.022	0.56
ABY6 ABY6V	.3750	9.525	.9060	23.012	.813	20.65	.345	8.76	.512	13.00	.781	19.84	.032	0.81
ABY7 ABY7V	.4375	11.112	1.0000	25.400	.875	22.22	.345	8.76	.618	15.70	.875	22.22	.032	0.81
ABY8 ABY8V	.5000	12.700	1.1250	28.575	.937	23.80	.401	10.19	.730	18.54	1.000	25.40	.032	0.81
ABY10 ABY10V	.6250	15.875	1.3750	34.925	1.200	30.48	.567	14.40	.856	21.74	1.250	31.75	.032	0.81
ABY12 ABY12V	.7500	19.050	1.5625	39.688	1.280	32.51	.620	15.75	.970	24.64	1.375	34.92	.044	1.12
ABY14 ABY14V	.8750	22.225	1.7500	44.450	1.400	35.56	.625	15.88	1.140	28.96	1.531	38.89	.044	1.12
ABY16 ABY16V	1.0000	25.400	2.1250	53.975	1.875	47.62	.835	21.21	1.278	32.46	1.875	47.62	.044	1.12
ABY20 ABY20V	1.2500	31.750	2.5000	63.500	1.875	47.62	1.005	25.53	1.523	38.68	2.250	57.15	.044	1.12
ABY24 ABY24V	1.5000	38.100	3.0000	76.200	2.250	57.15	1.175	29.84	1.800	45.72	2.672	67.87	.044	1.12

#The load ratings listed for this series of bearings do not take into account pin deflection. Excess pin deflection can cause a crack to traverse the ball sphere. (See page 24).

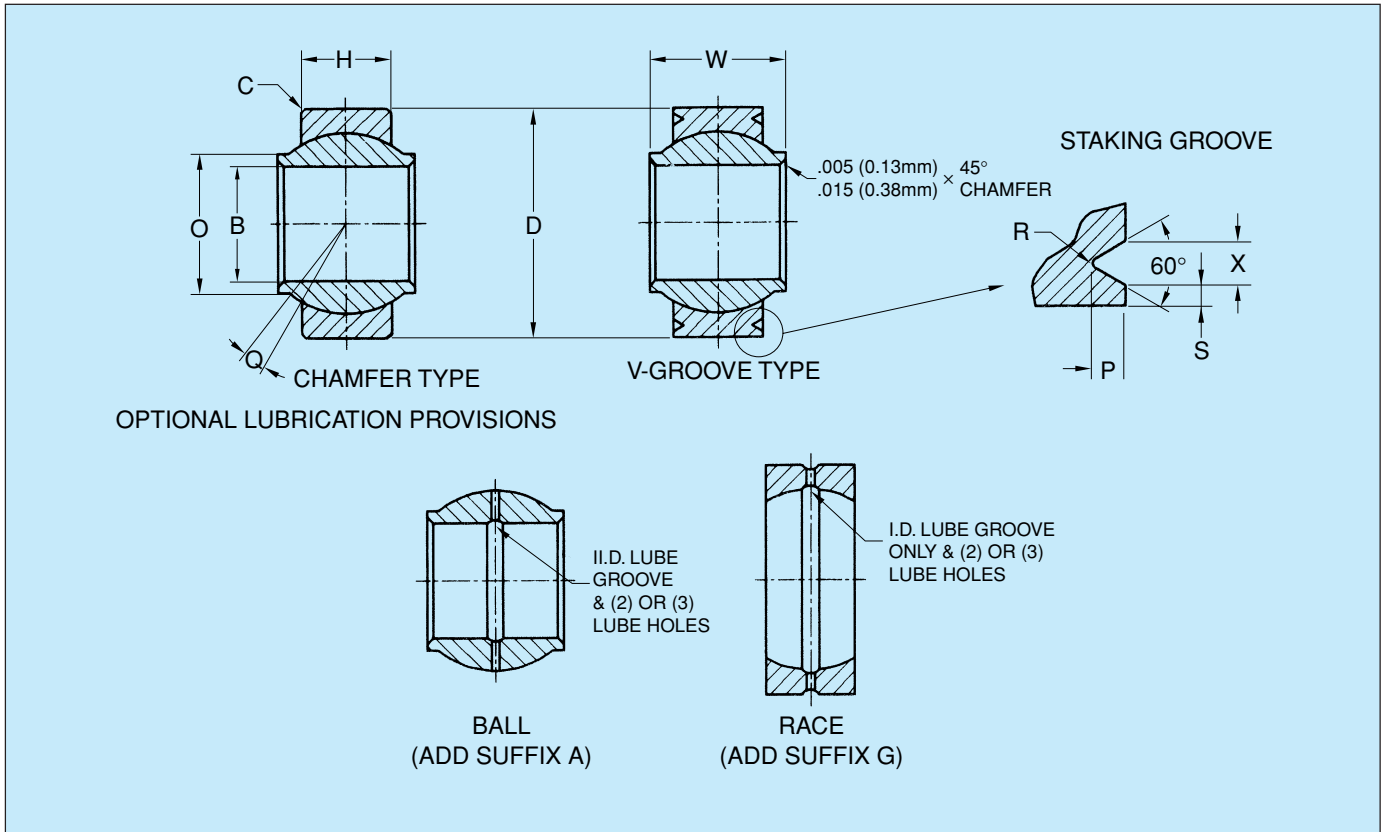

OPTIONAL LUBRICATION PROVISIONS

(Q) Misalign- ment	Staking Groove Data								Limit Static Radial Load				Approx. Weight	
	(P)		(R)		(S)		(X)		Bronze Race		Steel Race		lbs	kg
	Inch	mm	Inch	mm	Inch	mm	Inch	mm	lbs	N	lbs	N		
Ref.	+0.00	+0.00	+0.00	+0.00	+0.00	+0.00	+0.00	+0.00	+0.00					
	-0.15	-0.38	-0.10	-0.25	-0.10	-0.25	-0.10	-0.25						
15°	.030	0.76	.015	0.38	.020	0.51	.045	1.14	4000	17792	4100	18237	.018	0.009
24°	.030	0.76	.015	0.38	.020	0.51	.045	1.14	6800	30246	7100	31581	.036	0.017
20°	.030	0.76	.015	0.38	.020	0.51	.045	1.14	6800	30246	9000	40032	.025	0.012
23°	.030	0.76	.015	0.38	.020	0.51	.045	1.14	12700	56490	16000	71168	.068	0.031
22°	.030	0.76	.015	0.38	.020	0.51	.045	1.14	14300	63606	21800	96966	.095	0.043
20°	.030	0.76	.015	0.38	.020	0.51	.045	1.14	18700	83178	28500	126768	.159	0.073
20°	.040	1.02	.020	0.51	.030	0.76	.055	1.40	34400	153011	44500	197936	.245	0.112
18°	.060	1.52	.020	0.51	.030	0.76	.080	2.03	41500	184592	64000	284672	.315	0.143
18°	.060	1.52	.020	0.51	.030	0.76	.080	2.03	44800	199270	76700	341162	.430	0.195
21°	.060	1.52	.020	0.51	.030	0.76	.080	2.03	76000	338048	114000	507072	.831	0.377
21°	.060	1.52	.020	0.51	.030	0.76	.080	2.03	111500	495952	178000	791744	1.318	0.598
21°	.060	1.52	.020	0.51	.030	0.76	.080	2.03	128000	569344	256000	1138688	2.223	1.009



ANM, ARNM

Rod End Bearings - Self-Lubricating
AS81935, Males

For MS to NMB part number interchange, see pages 56-57.

Bearings listed in the tables are approved for procurement to AS81935 and AS81935/1 and AS81935/4.

Temperature: Operating temperature range per AS81935; -65° to 325°F (-54°C to 163°C). Broader temperature capabilities are achievable.

Option: See page 56-57 for MS options.

Notes: Stainless Steel Series is not available to MS., but may be ordered to NMB Part Number as indicated. Example: ANM8CR or ARNM12CR

MATERIALS

Part No.	Ball	Race	Liner	Body
Catalog No.	CRES 440C AMS 5630, 55-62 HRC	CRES 17-4PH AMS 5643, 23-37 HRC	*Teflon/Fabric Bonded to race I.D. No lub. required	4340 STL AMS6415 39-42 HRC, Cad. Plated
Catalog No. + CR	CRES 440C AMS 5630, 55-62 HRC	CRES 17-4PH AMS 5643, 23-35 HRC	*Teflon/Fabric Bonded to race I.D. No lub. required	CRES 17-4PH AMS 5643, Heat Treated Passivated

NMB Part Number Prefix	(B) Bore Diameter		(D) Head Diameter		(W) Ball Width		(H) Body Width		(O) Shoulder Diameter		Ball Diameter		(F) Ball C/L to End		(E) Thread Size	(L) Complete Thread		(Q) Misalign-ment
	Inch	mm	Inch	mm	Inch	mm	Inch	mm	Inch	mm	Inch	mm	Inch	mm		Inch	mm	
WIDE	+ .0000	+0.000	+ .010	+0.25	+ .000	+0.00	+ .005	+0.13					+ .010	+0.25		+ .031	+0.79	
M81935/1	- .0005	-0.013	- .010	-0.25	- .002	-0.05	- .005	-0.13	MIN	MIN	Ref.	Ref.	- .010	-0.25	UNJF-3A	- .031	-0.79	MIN
ANM3	.1900	4.826	.806	20.47	.437	11.10	.337	8.56	.300	7.62	.531	13.49	1.562	39.67	.3125-24	.968	24.59	15°
ANM4	.2500	6.350	.806	20.47	.437	11.10	.337	8.56	.300	7.62	.531	13.49	1.562	39.67	.3125-24	.968	24.59	15°
ANM5	.3125	7.938	.900	22.86	.437	11.10	.327	8.31	.360	9.14	.570	14.48	1.875	47.62	.3125-24	1.187	30.15	14°
ANM6	.3750	9.525	1.025	26.04	.500	12.70	.416	10.57	.470	11.94	.687	17.45	1.938	49.23	.3750-24	1.187	30.15	8°
ANM7	.4375	11.112	1.150	29.21	.562	14.27	.452	11.48	.540	13.72	.781	19.84	2.125	53.98	.4375-20	1.281	32.54	10°
ANM8	.5000	12.700	1.337	33.96	.625	15.88	.515	13.08	.610	15.49	.875	22.22	2.438	61.93	.5000-20	1.468	37.29	9°
ANM10	.6250	15.875	1.525	38.74	.750	19.05	.577	14.66	.750	19.05	1.062	26.97	2.625	66.68	.6250-18	1.562	39.67	12°
ANM12	.7500	19.050	1.775	45.08	.875	22.22	.640	16.26	.850	21.59	1.250	31.75	2.875	73.02	.7500-16	1.687	42.85	13°
ANM14	.8750	22.225	2.025	51.44	.875	22.22	.765	19.43	1.000	25.40	1.375	34.92	3.375	85.72	.8750-14	2.000	50.80	6°
ANM16	1.0000	25.400	2.775	70.48	1.375	34.92	1.015	25.78	1.270	32.26	1.875	47.62	4.125	104.78	1.2500-12	2.343	59.51	12°
NARROW																		
M81935/4																		
ARNM3	.1900	4.826	.680	17.27	.281	7.14	.228	5.79	.293	7.44	.406	10.31	1.315	33.40	.2500-28	.775	19.68	10°
ARNM4	.2500	6.350	.827	21.01	.343	8.71	.260	6.60	.364	9.25	.500	12.70	1.443	36.65	.2500-28	.775	19.68	10°
ARNM5	.3125	7.938	.984	24.99	.375	9.52	.291	7.39	.419	10.64	.570	14.48	1.948	49.48	.3125-24	1.187	30.15	10°
ARNM6	.3750	9.525	1.131	28.73	.406	10.31	.322	8.18	.475	12.06	.656	16.66	2.030	51.56	.3750-24	1.187	30.15	9°
ARNM7	.4375	11.112	1.294	32.87	.437	11.10	.353	8.97	.530	13.46	.718	18.24	2.250	57.15	.4375-20	1.281	32.54	8°
ARNM8	.5000	12.700	1.459	37.06	.500	12.70	.400	10.16	.600	15.24	.781	19.84	2.544	64.62	.5000-20	1.468	37.29	8°
ARNM10	.6250	15.875	1.763	44.78	.625	15.88	.510	12.95	.739	18.77	1.000	25.40	2.832	71.93	.6250-18	1.562	39.67	8°
ARNM12	.7500	19.050	2.140	54.36	.750	19.05	.603	15.32	.920	23.37	1.250	31.75	3.193	81.10	.7500-16	1.687	42.85	8°
ARNM14	.8750	22.225	2.372	60.25	.875	22.22	.713	18.11	.980	24.89	1.375	34.92	3.677	93.40	.8750-14	2.000	50.80	8°
ARNM16	1.0000	25.400	2.681	68.10	1.000	25.40	.807	20.50	1.118	28.40	1.562	39.67	3.968	100.79	1.0000-12	2.100	53.34	9°

* A trade name of E.I. duPont de Nemours & Co., Inc.

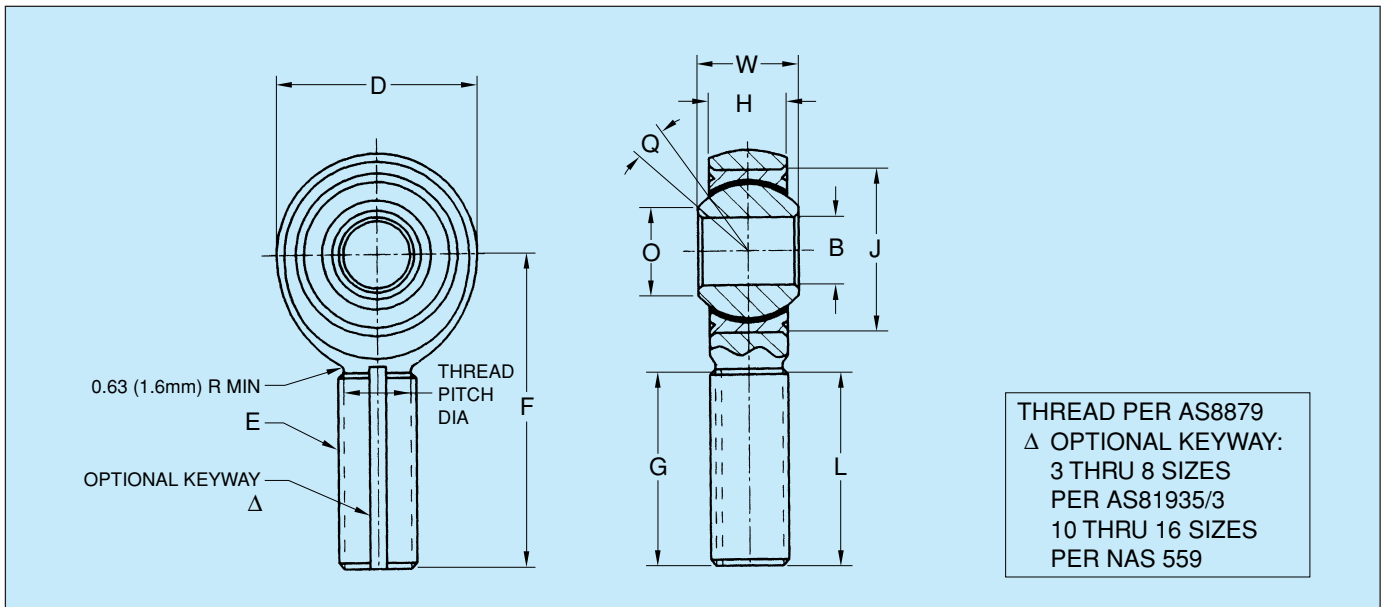

For keyway details, refer to the engineering section, pages 18-19.

(J) Housing I.D.		(G) Keyway Flat		No Load Roatational Breakaway Torque		Ultimate Static Radial Load		Axial Static Proof Load		Fatigue Load		Max. Weight	
Inch	mm	Inch	mm	In-lb	N-m	lbs	N	lbs	N	lbs	N	lbs	kg
MAX	MAX	+0.00	+0.00										
		-0.020	-0.51										
.6250	15.875	.980	24.89	.5-6	0.06-0.68	2360	10497	1000	4448	1470	6539	.072	0.033
.6250	15.875	.980	24.89	.5-6	0.06-0.68	4860	21617	1000	4448	2380	10586	.072	0.033
.6875	17.462	1.270	32.26	1-15	0.11-1.70	7180	31937	1100	4893	2770	12321	.087	0.040
.8125	20.638	1.235	31.37	1-15	0.11-1.70	8550	38030	1660	7384	3570	15879	.136	0.062
.9062	23.017	1.402	35.61	1-15	0.11-1.70	12000	53376	1850	8229	4800	21350	.183	0.083
1.0000	25.400	1.589	40.36	1-15	0.11-1.70	19500	86736	2040	9074	7680	34161	.278	0.127
1.1875	30.162	1.683	42.75	1-15	0.11-1.70	21900	97411	2430	10809	9180	40833	.424	0.193
1.3750	34.925	1.808	45.92	1-15	0.11-1.70	29300	130326	2810	12499	11600	51597	.639	0.290
1.6250	41.275	2.121	53.87	1-24	0.11-2.71	34500	153456	3320	14767	13100	58269	.963	0.437
2.1250	53.975	2.464	62.59	1-24	0.11-2.71	80300	357174	4340	19304	30400	135219	2.546	1.155
.5625	14.288	.896	22.76	.5-6	0.06-0.68	3000	13344	150	667	1100	4893	.030	0.014
.6562	16.667	.896	22.76	.5-6	0.06-0.68	5300	23574	430	1913	1500	6671	.045	0.021
.7500	19.050	1.308	33.22	1-15	0.11-1.70	8600	38253	700	3114	2400	10675	.081	0.037
.8125	20.638	1.308	33.22	1-15	0.11-1.70	13000	57824	1100	4893	3600	16013	.120	0.055
.9062	23.017	1.402	35.61	1-15	0.11-1.70	17800	79174	1400	6227	5000	22240	.172	0.078
1.0000	25.400	1.589	40.36	1-15	0.11-1.70	24200	107642	2040	9074	6800	30246	.254	0.116
1.1875	30.162	1.683	42.75	1-15	0.11-1.70	38500	171248	2430	10809	10800	48038	.455	0.207
1.4375	36.512	1.808	45.92	1-15	0.11-1.70	56600	251757	2940	13077	16000	71168	.774	0.351
1.5625	39.688	2.121	53.87	1-24	0.11-2.71	77400	344275	3190	14189	21900	97411	1.141	0.518
1.7500	44.450	2.221	56.41	1-24	0.11-2.71	101400	451027	3570	15879	28600	127213	1.646	0.747



MS to NMB Part Numbers

Rod End Bearings AS81935

Male

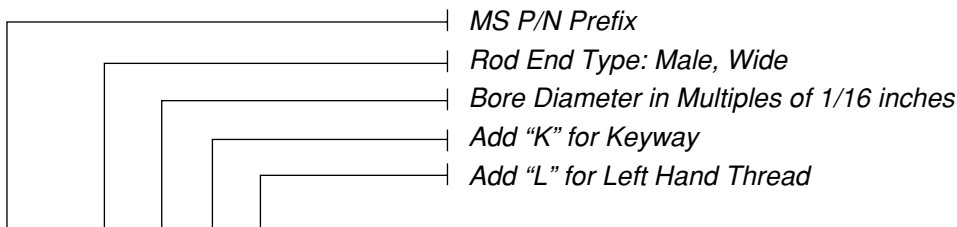

MS P/N M81935/1 - X X X

NMB P/N ANM X X X

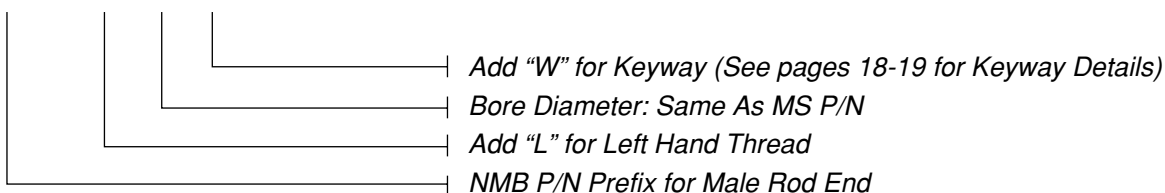

M81935/1

MS	NMB
M81935/1-3	ANM3
M81935/1-4	ANM4
M81935/1-5	ANM5
M81935/1-6	ANM6
M81935/1-7	ANM7
M81935/1-8	ANM8
M81935/1-10	ANM10
M81935/1-12	ANM12
M81935/1-14	ANM14
M81935/1-16	ANM16

M81935/1-K

MS	NMB
M81935/1-3K	ANM3W
M81935/1-4K	ANM4W
M81935/1-5K	ANM5W
M81935/1-6K	ANM6W
M81935/1-7K	ANM7W
M81935/1-8K	ANM8W
M81935/1-10K	ANM10W
M81935/1-12K	ANM12W
M81935/1-14K	ANM14W
M81935/1-16K	ANM16W

M81935/1-L

MS	NMB
M81935/1-3L	ANML3
M81935/1-4L	ANML4
M81935/1-5L	ANML5
M81935/1-6L	ANML6
M81935/1-7L	ANML7
M81935/1-8L	ANML8
M81935/1-10L	ANML10
M81935/1-12L	ANML12
M81935/1-14L	ANML14
M81935/1-16L	ANML16

M81935/1

MS	NMB
M81935/1-3KL	ANML3W
M81935/1-4KL	ANML4W
M81935/1-5KL	ANML5W
M81935/1-6KL	ANML6W
M81935/1-7KL	ANML7W
M81935/1-8KL	ANML8W
M81935/1-10KL	ANML10W
M81935/1-12KL	ANML12W
M81935/1-14KL	ANML14W
M81935/1-16KL	ANML16W

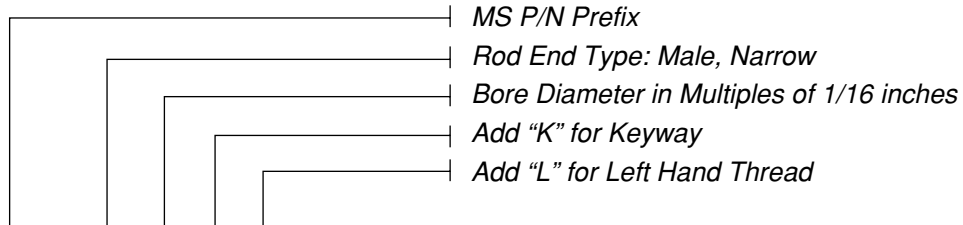

MS P/N M81935/4 - X X X

NMB P/N ARNM X X X

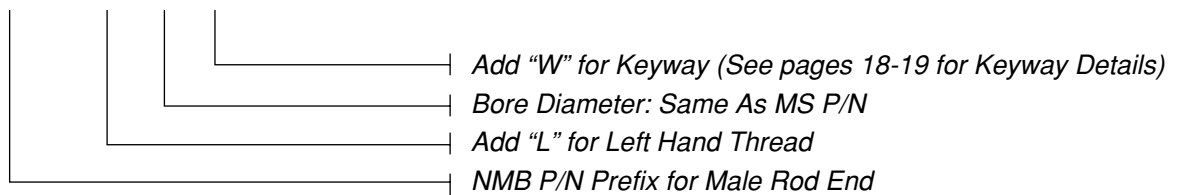

M81935/4

MS	NMB
M81935/4-3	ARNM3
M81935/4-4	ARNM4
M81935/4-5	ARNM5
M81935/4-6	ARNM6
M81935/4-7	ARNM7
M81935/4-8	ARNM8
M81935/4-10	ARNM10
M81935/4-12	ARNM12
M81935/4-14	ARNM14
M81935/4-16	ARNM16

M81935/4-K

MS	NMB
M81935/4-3K	ARNM3W
M81935/4-4K	ARNM4W
M81935/4-5K	ARNM5W
M81935/4-6K	ARNM6W
M81935/4-7K	ARNM7W
M81935/4-8K	ARNM8W
M81935/4-10K	ARNM10W
M81935/4-12K	ARNM12W
M81935/4-14K	ARNM14W
M81935/4-16K	ARNM16W

M81935/4-L

MS	NMB
M81935/4-3L	ARNML3
M81935/4-4L	ARNML4
M81935/4-5L	ARNML5
M81935/4-6L	ARNML6
M81935/4-7L	ARNML7
M81935/4-8L	ARNML8
M81935/4-10L	ARNML10
M81935/4-12L	ARNML12
M81935/4-14L	ARNML14
M81935/4-16L	ARNML16

M81935/4-KL

MS	NMB
M81935/4-3KL	ARNML3W
M81935/4-4KL	ARNML4W
M81935/4-5KL	ARNML5W
M81935/4-6KL	ARNML6W
M81935/4-7KL	ARNML7W
M81935/4-8KL	ARNML8W
M81935/4-10KL	ARNML10W
M81935/4-12KL	ARNML12W
M81935/4-14KL	ARNML14W
M81935/4-16KL	ARNML16W



ANF, ARNF

Rod End Bearings - Self-Lubricating
AS81935, Females

For MS to NMB Part number interchange, see page 60-61.

Bearings listed in the tables are approved for procurement to AS81935 and AS81935/2 and AS81935/5.

Temperature: Operating temperature range per AS81935; -65° to 325°F (-54°C to 163°C). Broader temperature capabilities are achievable.

Option: See page 60-61 for MS options.

Notes: Stainless Steel Series is not available to MS, but may be ordered to NMB Part Number as indicated.

Example: ANF12CR or ARNF6CR

MATERIALS

Part No.	Ball	Race	Liner	Body
Catalog No.	CRES 440C AMS 5630 55-62 HRC	CRES 17-4PH AMS 5643, 23-37 HRC	*Teflon/Fabric Bonded to race I.D. No lub. required	4340 STL AMS6415 39-42 HRC, Cad. Plated
Catalog No. + CR	CRES 440C AMS 5630, 55-62 HRC	CRES 17-4PH AMS 5643, 23-35 HRC	*Teflon/Fabric Bonded to race I.D. No lub. required	CRES 17-4PH/ AMS 5643, Heat Treated Passivated

NMB Part Number	(B) Bore Diameter		(D) Head Diameter		(W) Ball Width		(H) Body Width		(O) Shoulder Diameter		(F) Ball C/L to End		(E) Thread Size		(L) Complete Thread		(N) Shank Diameter		(Q) Misalign-ment	
	Inch	mm	Inch	mm	Inch	mm	Inch	mm	Inch	mm	Inch	mm		Inch	mm	Inch	mm			
WIDE	+0.000	+0.000	+0.010	+0.025	+0.000	+0.000	+0.005	+0.013			+0.10	+0.25					+0.010	+0.025		
M81935/2	-0.005	-0.013	-0.010	-0.025	-0.002	-0.005	-0.005	-0.013	MIN	MIN	Ref.	Ref.	-0.10	-0.25	UNJF-3B	MIN	MIN	-0.010	-0.025	MIN
ANF3	.1900	4.826	.806	20.47	.437	11.10	.337	8.56	.300	7.62	.531	13.49	1.375	34.92	.3125-24	.750	19.05	.422	10.72	15°
ANF4	.2500	6.350	.806	20.47	.437	11.10	.337	8.56	.300	7.62	.531	13.49	1.469	37.31	.3125-24	.750	19.05	.422	10.72	15°
ANF5	.3125	7.938	.900	22.86	.437	11.10	.327	8.31	.360	9.14	.570	15.06	1.625	41.28	.3750-24	.875	22.22	.485	12.32	14°
ANF6	.3750	9.525	1.025	26.04	.500	12.70	.416	10.57	.470	11.94	.687	17.45	1.812	46.02	.3750-24	1.000	25.40	.547	13.89	8°
ANF7	.4375	11.112	1.150	29.21	.562	14.28	.452	11.48	.540	13.72	.781	19.84	2.000	50.80	.4375-20	1.125	28.58	.610	15.49	10°
ANF8	.5000	12.700	1.337	33.96	.625	15.88	.515	13.08	.610	15.49	.875	22.22	2.250	57.15	.5000-20	1.250	31.75	.735	18.67	9°
ANF10	.6250	15.875	1.525	38.74	.750	19.05	.577	14.66	.750	19.05	1.062	26.98	2.500	63.50	.6250-18	1.375	34.92	.860	21.84	12°
ANF12	.7500	19.050	1.775	45.08	.875	22.22	.640	16.26	.850	21.59	1.218	31.75	2.875	73.02	.7500-16	1.625	41.28	.985	25.02	13°
ANF14	.8750	22.225	2.025	51.44	.875	22.22	.765	19.43	1.000	25.40	1.375	34.92	3.375	85.72	.8750-14	1.875	47.62	1.110	28.19	6°
ANF16	1.0000	25.400	2.775	70.48	1.375	34.92	1.015	25.78	1.270	32.26	1.875	47.62	4.125	104.78	1.2500-12	2.125	53.98	1.688	42.88	12°
NARROW																				
M81935/5																				
ARNF3	.1900	4.826	.680	17.27	.281	7.14	.228	5.79	.293	7.44	.406	10.31	1.210	30.73	.2500-28	.625	15.88	.329	8.36	10°
ARNF4	.2500	6.350	.827	21.01	.343	8.71	.260	6.60	.364	9.25	.500	12.70	1.338	33.99	.2500-28	.625	15.88	.329	8.36	10°
ARNF5	.3125	7.938	.984	24.99	.375	9.52	.291	7.39	.419	10.64	.562	14.28	1.566	39.78	.3125-24	.750	19.05	.413	10.49	10°
ARNF6	.3750	9.525	1.131	28.73	.406	10.31	.332	8.43	.475	12.06	.656	16.66	1.908	48.46	.3750-24	1.000	25.40	.501	12.72	9°
ARNF7	.4375	11.112	1.294	32.87	.437	11.10	.353	8.97	.530	13.46	.718	18.24	2.125	53.97	.4375-20	1.125	28.58	.584	14.83	8°
ARNF8	.5000	12.700	1.459	37.06	.500	12.70	.400	10.16	.600	15.24	.813	20.65	2.356	53.98	.5000-20	1.250	31.75	.672	17.07	8°
ARNF10	.6250	15.875	1.763	44.78	.625	15.88	.510	12.95	.793	20.14	.968	24.59	2.707	68.76	.6250-18	1.375	34.92	.845	21.46	8°
ARNF12	.7500	19.050	2.140	54.36	.750	19.05	.603	15.32	.920	23.37	1.187	30.15	3.193	81.10	.7500-16	1.625	41.28	1.017	25.83	8°
ARNF14	.8750	22.225	2.372	60.25	.875	22.22	.713	18.11	.980	24.89	1.312	33.32	3.677	93.40	.8750-14	1.875	47.62	1.187	30.15	8°
ARNF16	1.0000	25.400	2.681	68.10	1.000	25.40	.807	20.50	1.118	28.40	1.500	38.10	4.101	104.16	1.0000-12	2.125	53.98	1.356	34.44	9°

* A trade name of E.I. duPont de Nemours & Co., Inc.

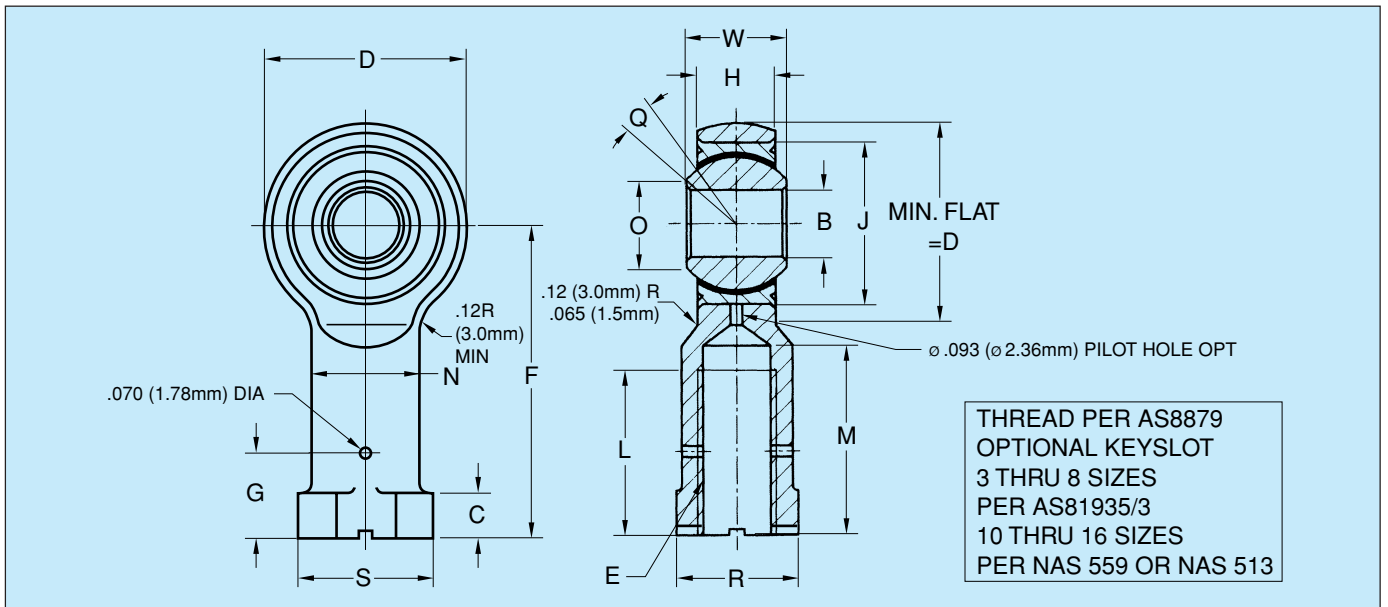

For keyslot details, refer to the engineering section, pages 18-19.

(M)		(C)		(R)		(S)		(G)		(J)		No Load Rotational Breakaway Torque		Ultimate Static Radial Load		Axial Static Proof Load		Fatigue Load		Max. Weight	
Drill Depth		Flange Thickness		Wrench Flat		Across Corners or Diameter		Drill C/L to End		Housing I.D.		In-lb	N-m	lbs	N	lbs	N	lbs	N	lbs	kg
Inch	mm	In-lb	N-m	Inch	mm	Inch	mm	Inch	mm	Inch	mm										
MAX	MAX	+0.010	+0.25	+0.002	+0.05	Ref.	Ref.			MAX	MAX										
		-0.062	-1.57	-0.10	-0.25																
.875	22.22	.188	4.78	.437	11.10	.500	12.70	.375	9.52	.6250	15.875	.5-6	0.06-0.68	2360	10497	1000	4448	1470	6539	.080	0.037
.875	22.22	.188	4.78	.437	11.10	.500	12.70	.375	9.52	.6250	15.875	.5-6	0.06-0.68	4860	21617	1000	4448	2380	10586	.084	0.039
1.000	25.40	.250	6.35	.500	12.70	.580	14.73	.437	11.10	.6875	17.462	1-15	0.11-1.70	7180	31937	1100	4893	3020	13433	.102	0.047
1.125	28.58	.250	6.35	.562	14.27	.660	16.76	.437	11.10	.8125	20.638	1-15	0.11-1.70	8550	38030	1660	7384	3570	15879	.161	0.073
1.250	31.75	.250	6.35	.625	15.88	.720	18.29	.500	12.70	.9062	23.017	1-15	0.11-1.70	12000	53376	1850	8229	4800	21350	.212	0.097
1.375	34.92	.250	6.35	.750	19.05	.880	22.35	.562	14.27	1.0000	25.400	1-15	0.11-1.70	19500	86736	2040	9074	8260	36740	.325	0.148
1.500	38.10	.375	9.53	.875	22.22	1.020	25.91	.687	17.45	1.1875	30.162	1-15	0.11-1.70	21900	97411	2430	10809	9180	40833	.481	0.219
1.750	44.45	.375	9.52	1.000	25.40	1.160	29.46	.812	20.62	1.3750	34.925	1-15	0.11-1.70	29300	130326	2810	12499	11600	51597	.673	0.306
2.062	52.37	.500	12.70	1.125	28.58	1.300	33.02	.937	23.80	1.6250	41.275	1-24	0.11-2.71	34500	153456	3320	14767	13100	58269	.959	0.435
2.312	58.72	.563	14.30	1.750	44.45	2.020	51.31	1.312	33.32	2.1250	53.975	1-24	0.11-2.71	80300	357174	4340	19304	30400	135219	2.717	1.233
.750	19.05	.188	4.78	.375	9.52	.430	10.92	.312	7.92	.5625	14.288	.5-6	0.06-0.68	3000	13344	150	667	1100	4893	.044	0.020
.750	19.05	.188	4.78	.375	9.52	.430	10.92	.312	7.92	.6562	16.667	.5-6	0.06-0.68	5500	24464	430	1913	1300	5782	.052	0.024
.875	22.22	.188	4.78	.437	11.10	.500	12.70	.375	9.52	.7500	19.050	1-15	0.11-1.70	8900	39587	700	3114	2000	8896	.087	0.039
1.125	28.58	.250	6.35	.625	15.88	.720	18.29	.437	11.10	.8125	20.638	1-15	0.11-1.70	13400	56903	1100	4893	3100	13789	.137	0.062
1.250	31.75	.250	6.35	.625	15.88	.720	18.29	.500	12.70	.9062	23.017	1-15	0.11-1.70	18200	80954	1400	6227	4200	18682	.193	0.088
1.375	34.92	.375	9.52	.875	22.22	1.020	25.91	.562	14.27	1.0000	25.400	1-15	0.11-1.70	24600	109421	2040	9074	5700	25354	.279	0.127
1.500	38.10	.375	9.52	.875	22.22	1.020	25.91	.687	17.45	1.1875	30.162	1-15	0.11-1.70	39500	175696	2430	10809	9200	40922	.504	0.229
1.750	44.45	.500	12.70	1.125	28.58	1.300	33.02	.812	20.62	1.4375	36.512	1-15	0.11-1.70	57200	254426	2940	13077	13500	60048	.860	0.390
2.062	52.37	.500	12.70	1.250	31.75	1.375	34.92	.937	23.80	1.5625	39.688	1-24	0.11-2.71	77800	346054	3100	13789	18400	81843	1.266	0.574
2.312	58.72	.500	12.70	2.375	60.32	1.590	40.39	1.062	26.97	1.7500	44.450	1-24	0.11-2.71	101000	449248	3570	15879	24000	106752	1.814	0.823



MS to NMB Part Numbers Rod End Bearings AS81935 Female

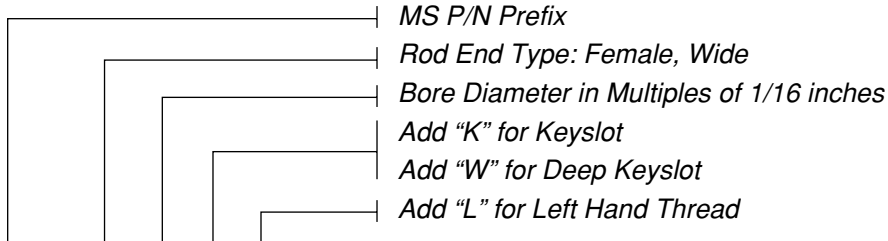

MS P/N M81935/2 - X X X

NMB P/N ANF X X X

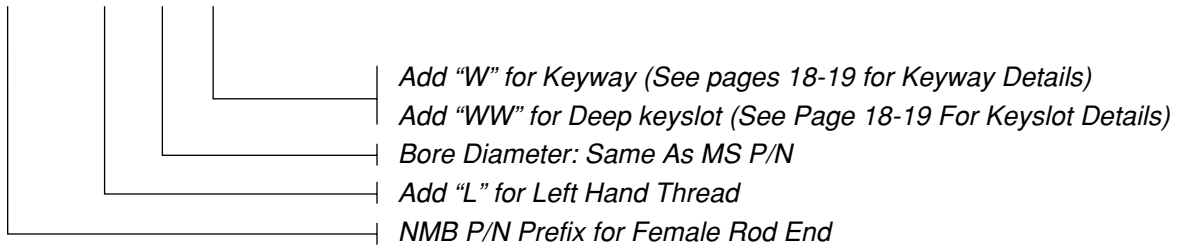

M81935/2

MS	NMB
M81935/2-3	ANF3
M81935/2-4	ANF4
M81935/2-5	ANF5
M81935/2-6	ANF6
M81935/2-7	ANF7
M81935/2-8	ANF8
M81935/2-10	ANF10
M81935/2-12	ANF12
M81935/2-14	ANF14
M81935/2-16	ANF16

M81935/2-K

MS	NMB
M81935/2-3K	ANF3W
M81935/2-4K	ANF4W
M81935/2-5K	ANF5W
M81935/2-6K	ANF6W
M81935/2-7K	ANF7W
M81935/2-8K	ANF8W
M81935/2-10K	ANF10W
M81935/2-12K	ANF12W
M81935/2-14K	ANF14W
M81935/2-16K	ANF16W

M81935/2-W

MS	NMB
M81935/2-3W	ANF3WW
M81935/2-4W	ANF4WW
M81935/2-5W	ANF5WW
M81935/2-6W	ANF6WW
M81935/2-7W	ANF7WW
M81935/2-8W	ANF8WW
M81935/2-10W	ANF10WW
M81935/2-12W	ANF12WW
M81935/2-14W	ANF14WW
M81935/2-16W	ANF16WW

M81935/2-L

MS	NMB
M81935/2-3L	ANFL3
M81935/2-4L	ANFL4
M81935/2-5L	ANFL5
M81935/2-6L	ANFL6
M81935/2-7L	ANFL7
M81935/2-8L	ANFL8
M81935/2-10L	ANFL10
M81935/2-12L	ANFL12
M81935/2-14L	ANFL14
M81935/2-16L	ANFL16

M81935/2-KL

MS	NMB
M81935/2-3KL	ANFL3W
M81935/2-4KL	ANFL4W
M81935/2-5KL	ANFL5W
M81935/2-6KL	ANFL6W
M81935/2-7KL	ANFL7W
M81935/2-8KL	ANFL8W
M81935/2-10KL	ANFL10W
M81935/2-12KL	ANFL12W
M81935/2-14KL	ANFL14W
M81935/2-16KL	ANFL16W

M81935/2-WL

MS	NMB
M81935/2-3WL	ANFL3WW
M81935/2-4WL	ANFL4WW
M81935/2-5WL	ANFL5WW
M81935/2-6WL	ANFL6WW
M81935/2-7WL	ANFL7WW
M81935/2-8WL	ANFL8WW
M81935/2-10WL	ANFL10WW
M81935/2-12WL	ANFL12WW
M81935/2-14WL	ANFL14WW
M81935/2-16WL	ANFL16WW

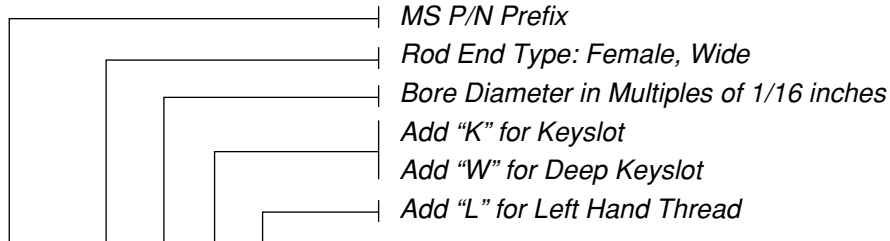

MS P/N M81935/5 - X X X

NMB P/N ARNF X X X

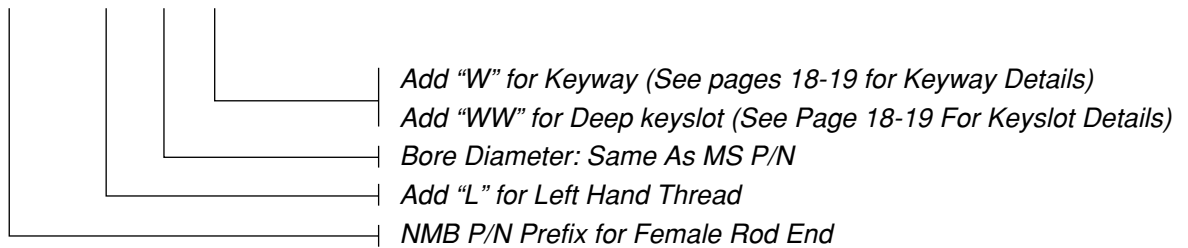

M81935/5

MS	NMB
M81935/5-3	ARNF3
M81935/5-4	ARNF4
M81935/5-5	ARNF5
M81935/5-6	ARNF6
M81935/5-7	ARNF7
M81935/5-8	ARNF8
M81935/5-10	ARNF10
M81935/5-12	ARNF12
M81935/5-14	ARNF14
M81935/5-16	ARNF16

M81935/5-K

MS	NMB
M81935/5-3K	ARNF3W
M81935/5-4K	ARNF4W
M81935/5-5K	ARNF5W
M81935/5-6K	ARNF6W
M81935/5-7K	ARNF7W
M81935/5-8K	ARNF8W
M81935/5-10K	ARNF10W
M81935/5-12K	ARNF12W
M81935/5-14K	ARNF14W
M81935/5-16K	ARNF16W

M81935/5-W

MS	NMB
M81935/5-3W	ARNF3WW
M81935/5-4W	ARNF4WW
M81935/5-5W	ARNF5WW
M81935/5-6W	ARNF6WW
M81935/5-7W	ARNF7WW
M81935/5-8W	ARNF8WW
M81935/5-10W	ARNF10WW
M81935/5-12W	ARNF12WW
M81935/5-14W	ARNF14WW
M81935/5-16W	ARNF16WW

M81935/2-L

MS	NMB
M81935/5-3L	ARNFL3
M81935/5-4L	ARNFL4
M81935/5-5L	ARNFL5
M81935/5-6L	ARNFL6
M81935/5-7L	ARNFL7
M81935/5-8L	ARNFL8
M81935/5-10L	ARNFL10
M81935/5-12L	ARNFL12
M81935/5-14L	ARNFL14
M81935/5-16L	ARNFL16

M81935/2-KL

MS	NMB
M81935/5-3KL	ARNFL3W
M81935/5-4KL	ARNFL4W
M81935/5-5KL	ARNFL5W
M81935/5-6KL	ARNFL6W
M81935/5-7KL	ARNFL7W
M81935/5-8KL	ARNFL8W
M81935/5-10KL	ARNFL10W
M81935/5-12KL	ARNFL12W
M81935/5-14KL	ARNFL14W
M81935/5-16KL	ARNFL16W

M81935/5-WL

MS	NMB
M81935/5-3WL	ARNFL3WW
M81935/5-4WL	ARNFL4WW
M81935/5-5WL	ARNFL5WW
M81935/5-6WL	ARNFL6WW
M81935/5-7WL	ARNFL7WW
M81935/5-8WL	ARNFL8WW
M81935/5-10WL	ARNFL10WW
M81935/5-12WL	ARNFL12WW
M81935/5-14WL	ARNFL14WW
M81935/5-16WL	ARNFL16WW



ART-E, ART

Rod End Bearings - Self-Lubricating
3-Piece, Male & Female

Plating: Body Cadmium plated per AMS-QQ-P-416, Type II, Class 2.
 Dimensions: All dimensions apply After plating.
 Temperature: -65° to 250°F (-54°C to 121°C).
 Option: 1. For left hand threads add "L" to prefix.
 2. For keyway or keyslot per NAS 559 and suffix "W" to part number.
 Qualification: Bearings in the tables below are approved for MS21242 (Male body) and MS21243 (Female body)

MATERIALS

Part No.	Ball	Race	Liner	Body
Catalog No.	CRES 440C Heat Treated To 55-62 HRC	CRES 410 Heat Treated To 23-35 HRC	*Teflon/Fabric Bonded to race I.D.	4340 STL Heat Treated To 39-42 HRC, Cad. Plated
Catalog No. + CR	CRES 440C Heat Treated To 55-62 HRC	CRES 410 Heat Treated To 23-35 HRC	*Teflon/Fabric Bonded to race I.D.	CRES 17-4PH Heat Treated

Notes: Stainless Steel Series is not available to MS, but may be ordered to NMB Part Number as indicated.
 Example: ARTL12CR

MALE

NMB Part Number	(B) Bore Diameter		(D) Head Diameter		(W) Ball Width		(H) Body Width		(O) Shoulder Diameter		(F) Ball C/L to End		(E) Thread Size	(L) Complete Thread		(Q) Misalign-ment		
	Inch	mm	Inch	mm	Inch	mm	Inch	mm	Inch	mm	Inch	mm		Inch	mm			
MS21242	+0.000	+0.000	+0.010	+0.25	+0.000	+0.00	+0.005	+0.13	MIN	MIN	Ref.	Ref.	+0.010	+0.25	UNJF-3A	+0.031	+0.79	MIN
	-0.005	-0.013	-0.010	-0.25	-0.002	-0.05	-0.005	-0.13					-0.010	-0.25		-0.031	-0.79	
ART3E	.1900	4.826	.806	20.47	.437	11.10	.337	8.56	.300	7.62	.531	13.49	1.562	39.67	.3125-24	.968	24.59	15°
ART4E	.2500	6.350	.806	20.47	.437	11.10	.337	8.56	.300	7.62	.531	13.49	1.562	39.67	.3125-24	.968	24.59	15°
ART5E	.3125	7.938	.900	22.86	.437	11.10	.327	8.31	.360	9.14	.593	15.06	1.875	47.62	.3125-24	1.187	30.15	14°
ART6E	.3750	9.525	1.025	26.04	.500	12.70	.416	10.57	.470	11.94	.687	17.45	1.938	49.23	.3750-24	1.187	30.15	8°
ART7E	.4375	11.112	1.150	29.21	.562	14.28	.452	11.48	.540	13.72	.781	19.84	2.125	53.98	.4375-20	1.281	32.54	10°
ART8E	.5000	12.700	1.337	33.96	.625	15.88	.515	13.08	.610	15.49	.875	22.22	2.438	61.93	.5000-20	1.468	37.29	9°
ART10E	.6250	15.875	1.525	38.74	.750	19.05	.577	14.66	.750	19.05	1.062	26.98	2.625	66.68	.6250-18	1.562	39.68	12°
ART12E	.7500	19.050	1.775	45.08	.875	22.22	.640	16.26	.850	21.59	1.250	31.75	2.875	73.02	.7500-16	1.687	42.85	13°
ART14E	.8750	22.225	2.025	51.44	.875	22.22	.765	19.43	1.000	25.40	1.375	34.92	3.375	85.72	.8750-14	2.000	50.80	6°
ART16E	1.0000	25.400	2.775	70.48	1.375	34.92	1.015	25.78	1.270	32.26	1.875	47.62	4.125	104.78	1.2500-12	2.343	59.51	12°

FEMALE

NMB Part Number	(B) Bore Diameter		(D) Head Diameter		(W) Ball Width		(H) Body Width		(O) Shoulder Diameter		(F) Ball C/L to End		(E) Thread Size	(L) Complete Thread		(N) Shank Diameter	(Q) Misalign-ment			
	Inch	mm	Inch	mm	Inch	mm	Inch	mm	Inch	mm	Inch	mm		Inch	mm	Inch	mm			
MS21243	+0.000	+0.000	+0.010	+0.25	+0.000	+0.00	+0.005	+0.13	MIN	MIN	Ref.	Ref.	+0.010	+0.25	UNJF-3B	MIN	MIN	+0.010	+0.25	MIN
	-0.005	-0.013	-0.010	-0.25	-0.002	-0.05	-0.005	-0.13					-0.010	-0.25		-0.010	-0.25			
ART3	.1900	4.826	.806	20.47	.437	11.10	.337	8.56	.300	7.62	.531	13.49	1.375	34.92	.3125-24	.750	19.05	.422	10.72	15°
ART4	.2500	6.350	.806	20.47	.437	11.10	.337	8.56	.300	7.62	.531	13.49	1.469	37.31	.3125-24	.750	19.05	.422	10.72	15°
ART5	.3125	7.938	.900	22.86	.437	11.10	.327	8.31	.360	9.14	.593	15.06	1.625	41.28	.3750-24	.875	22.22	.485	12.32	14°
ART6	.3750	9.525	1.025	26.04	.500	12.70	.416	10.57	.470	11.94	.687	17.45	1.812	46.02	.3750-24	1.000	25.40	.547	13.89	8°
ART7	.4375	11.112	1.150	29.21	.562	14.28	.452	11.48	.540	13.72	.781	19.84	2.000	50.80	.4375-20	1.125	28.58	.610	15.49	10°
ART8	.5000	12.700	1.337	33.96	.625	15.88	.515	13.08	.610	15.49	.875	22.22	2.250	57.15	.5000-20	1.250	31.75	.735	18.67	9°
ART10	.6250	15.875	1.525	38.74	.750	19.05	.577	14.66	.750	19.05	1.062	26.98	2.500	63.50	.6250-18	1.375	34.92	.860	21.84	12°
ART12	.7500	19.050	1.775	45.08	.875	22.22	.640	16.26	.850	21.59	1.250	31.75	2.875	73.02	.7500-16	1.625	41.28	.985	25.02	13°
ART14	.8750	22.225	2.025	51.44	.875	22.22	.765	19.43	1.000	25.40	1.375	34.92	3.375	85.72	.8750-14	1.875	47.62	1.110	28.19	6°
ART16	1.0000	25.400	2.775	70.48	1.375	34.92	1.015	25.78	1.270	32.26	1.875	47.62	4.125	104.78	1.2500-12	2.125	53.98	1.688	42.88	12°

* A trade name of E.I. duPont de Nemours & Co., Inc.

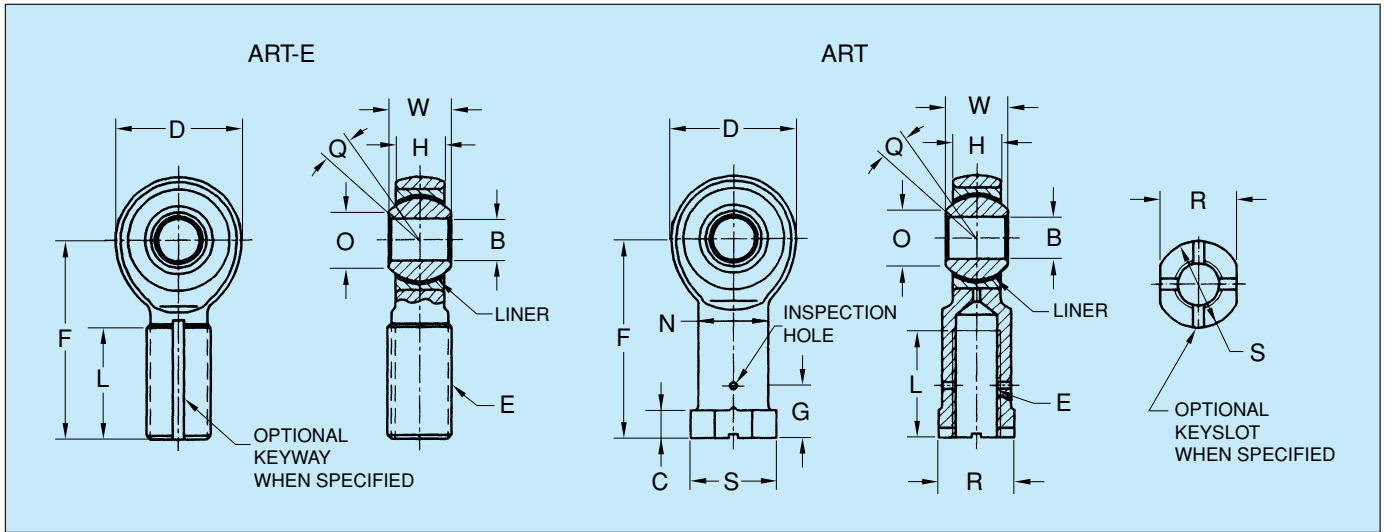

Housing I.D.		Keyway Flat		No Load Rotational Breakaway Torque		Ultimate Static Radial Load		Axial Static Proof Load		Fatigue Load		Max. Weight	
Inch	mm	Inch	mm	In-lb	N-m	lbs	N	lbs	N	lbs	N	lbs	kg
Ref.	Ref.	+0.000	+0.00										
		-.020	-0.51										
.6250	15.875	.980	24.89	.5-6	0.06-0.68	2360	10497	1000	4448	1470	6539	0.072	0.033
.6250	15.875	.980	24.89	.5-6	0.06-0.68	4860	21617	1000	4448	2380	10586	0.072	0.033
.6875	17.462	1.270	32.26	1-10	0.11-1.13	7180	31937	1100	4893	2770	12321	0.087	0.040
.8125	20.638	1.235	31.37	1-10	0.11-1.13	8550	38030	1660	7384	3570	15879	0.136	0.062
.9062	23.017	1.402	35.61	1-10	0.11-1.13	12000	53376	1850	8229	4800	21350	0.183	0.083
1.0000	25.400	1.589	40.36	1-10	0.11-1.13	19500	86736	2040	9074	7680	34161	0.278	0.127
1.1875	30.162	1.683	42.75	1-10	0.11-1.13	21900	97411	2430	10809	9180	40833	0.424	0.193
1.3750	34.925	1.808	45.92	1-10	0.11-1.13	29300	130326	2810	12499	11600	51597	0.639	0.290
1.6250	41.275	2.121	53.87	2-16	0.23-1.81	34500	153456	3320	14767	13100	58269	0.963	0.437
2.1250	53.975	2.464	62.59	2-16	0.23-1.81	80300	357174	4340	19304	30400	135219	2.546	1.155

(C) Flange Thickness		(R) Wrench Flat		(S) Across Corners or Diameter		(G) Drill C/L to End		Housing I.D.		No Load Rotational Breakaway Torque		Ultimate Static Radial Load		Axial Static Proof Load		Fatigue Load		MAX Weight	
Inch	mm	Inch	mm	Inch	mm	Inch	mm	Inch	mm	In-lb	N-m	lbs	N	lbs	N	lbs	N	lbs	kg
+0.010	+0.25	+0.002	+0.05	Ref.	Ref.	+0.020	+0.51	Ref.	Ref.										
-.062	-1.57	-.010	-0.25	Ref.	Ref.	-.020	-0.51	Ref.	Ref.										
.188	4.78	.437	11.10	.500	12.70	.375	9.52	.6250	15.875	.5-6	0.06-0.68	2360	10487	1000	4448	1470	6539	.080	0.037
.188	4.78	.437	11.10	.500	12.70	.375	9.52	.6250	15.875	.5-6	0.06-0.68	4860	21617	1000	4448	2380	10586	.084	0.039
.250	6.35	.500	12.70	.580	14.73	.437	11.10	.6875	17.462	1-10	0.11-1.13	7180	31937	1100	4893	3020	13433	.102	0.047
.250	6.35	.562	14.27	.660	16.76	.437	11.10	.8125	20.638	1-10	0.11-1.13	8550	38030	1660	7384	3570	15879	.161	0.073
.250	6.35	.625	15.88	.720	18.29	.500	12.70	.9062	23.017	1-10	0.11-1.13	12000	53376	1850	8229	4800	21350	.212	0.097
.250	6.35	.750	19.05	.880	22.35	.562	14.28	1.0000	25.400	1-10	0.11-1.13	19500	86736	2040	9074	8260	36740	.325	0.148
.375	9.52	.875	22.22	1.020	25.91	.687	17.45	1.1875	30.162	1-10	0.11-1.13	21900	97411	2430	10809	9180	40833	.481	0.219
.375	9.52	1.000	25.40	1.160	29.46	.812	20.62	1.3750	34.925	1-10	0.11-1.13	29300	130326	2810	12499	11600	51597	.673	0.306
.500	12.70	1.125	28.38	1.300	33.02	.937	23.80	1.6250	41.275	2-16	0.23-1.81	34500	153456	3320	14767	13100	58269	.959	0.435
.563	14.30	1.750	44.45	2.020	51.31	1.312	33.32	2.1250	53.975	2-16	0.23-1.81	80300	357174	4340	19304	30400	135219	2.717	1.233



ARHT-E, ARHT

Rod End Bearings - Self-Lubricating
3 Piece, Heavy Duty, Male & Female

- Plating: When specified in materials block, body Cadmium plated all surfaces per AMS-QQ-P-416, Type I, Class 2.
- Dimensions: Dimensions apply after plating.
- Option:
1. For left hand threads add "L" to prefix. Examples: ARHTL4E or ARHTL4.
 2. For keyway or keyslot options, add suffix "W" to part number.
 3. For "J" from threads per AS8879, add suffix "J" to part number. Examples: ARHT10EJW or ARHT10JW.
 4. To specify CRES 17-4PH race material, add suffix "H" to designation. Examples: ARHT8ECRH or ARHT8CRH.
- Notes: UNF-3A = Male, UNF-3B = Female

MATERIALS

Part No.	Ball	Race	Liner	Body
Basic No.	CRES 440C, 55-62 HRC	CRES 410 Heat Treated	*Teflon/Fabric Permanently Bonded to race I.D.	C.M. STL, Heat Treated Cad. Plated
No. + CR	CRES 440C 55-62 HRC	CRES 410 Heat Treated	*Teflon/Fabric Permanently Bonded to race I.D.	CRES 17-4PH, Heat Treated

NMB Part Number	(B) Bore Diameter		(D) Head Diameter		(W) Ball Width		(H) Body Width		(O) Ball Diameter		(O) Shoulder Diameter		(F) Ball C/L to End		(E) Thread Size	(Q) Misalign-ment
	Inch	mm	Inch	mm	Inch	mm	Inch	mm	Inch	mm	Inch	mm	Inch	mm		
	+0.000	+0.000	+0.010	+0.25	+0.000	+0.00	+0.005	+0.13					+0.010	+0.25	UNF-3A	
	-0.0005	-0.013	.010	-0.25	-.002	-0.05	-.005	-0.13	Ref.	Ref.	Ref.	Ref.	-.010	-0.25	UNF-3B	Ref.
ARHT4E ARHT4	.2500	6.350	.806	20.47	.375	9.52	.337	8.56	.531	13.49	.375	9.52	1.562	39.67	5/16-24	5°
ARHT5E ARHT5	.3125	7.938	.900	22.86	.437	11.10	.327	8.31	.593	15.06	.401	10.18	1.875	47.62	3/8-24	14°
ARHT6E ARHT6	.3750	9.525	1.025	26.04	.500	12.70	.416	10.57	.687	17.45	.471	11.96	1.938	49.23	7/16-20	9°
ARHT7E ARHT7	.4375	11.112	1.150	29.21	.562	14.27	.452	11.48	.781	19.84	.542	13.77	2.125	53.98	1/2-20	10°
ARHT8E ARHT8	.5000	12.700	1.337	33.96	.625	15.88	.515	13.08	.875	22.22	.612	15.54	2.438	61.93	5/8-18	9°
ARHT10E ARHT10	.6250	15.875	1.525	38.74	.750	19.05	.577	14.66	1.062	26.97	.752	19.10	2.625	66.68	3/4-16	12°
ARHT12E ARHT12	.7500	19.050	1.775	45.08	.875	22.22	.640	16.26	1.250	31.75	.892	22.66	2.875	73.02	7/8-14	13°
													2.875	73.02		

* A trade name of E.I. duPont de Nemours & Co., Inc.

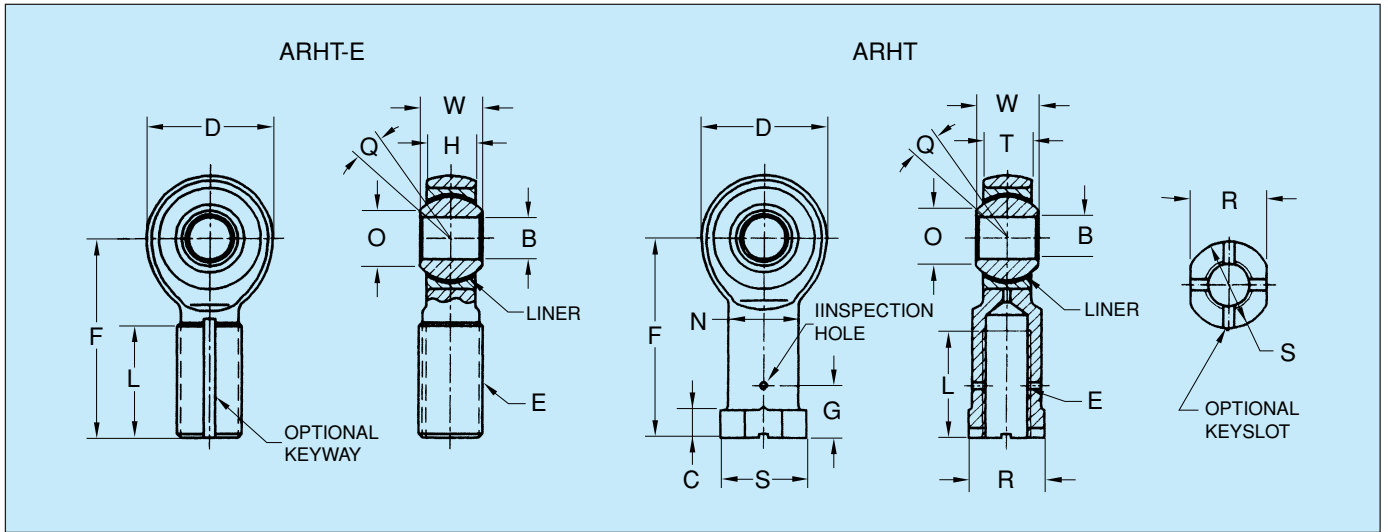

(L) Thread Length		(L) Thread Depth		(G) Drill C/L To End		(N) Shank Diameter		(S) Flange Diameter		(C) Flange Thickness		(R) Wrench Flat		No Load Rotational Breakaway Torque		Ultimate Static Radial Load		Axial Static Proof Load		Approx. Weight	
Inch	mm	Inch	mm	Inch	mm	Inch	mm	Inch	mm	In-lb	N-m	Inch	mm	In-lb	N-m	lbs	N	lbs	N	lbs	kg
+.031	+0.79	—	—	—	—	+.010	+0.25	—	—	+.010	+0.25	+.002	+0.05	—	—	—	—	—	—	—	—
-.031	-0.79	Min.	Min.	Ref.	Ref.	-.010	-0.25	Ref.	Ref.	-.062	-1.57	-.010	-0.25								
.968	24.59	—	—	—	—	—	—	—	—	—	—	—	—	.5-6	0.06-0.68	7550	33582	1000	4448	.067	0.030
—	—	.750	19.05	.375	9.52	.485	12.32	.562	14.27	.188	4.78	.500	12.70							.084	0.038
1.187	30.15	—	—	—	—	—	—	—	—	—	—	—	—	1-10	0.11-1.13	9200	40922	1100	4893	.095	0.043
—	—	.875	22.22	.437	11.10	.547	13.89	.625	15.88	.250	6.35	.562	14.27							.102	0.046
1.187	30.15	—	—	—	—	—	—	—	—	—	—	—	—	1-10	0.11-1.13	10900	48483	1660	7384	.140	0.064
—	—	1.000	25.40	.500	12.70	.610	15.49	.687	17.45	.250	6.35	.625	15.88							.160	0.073
1.281	32.54	—	—	—	—	—	—	—	—	—	—	—	—	1-10	0.11-1.13	14050	62494	1850	8229	.210	0.095
—	—	1.125	28.58	.562	14.27	.735	18.67	.875	22.22	.250	6.35	.750	19.05							.230	0.104
1.468	37.29	—	—	—	—	—	—	—	—	—	—	—	—	1-10	0.11-1.13	23400	104083	2040	9074	.330	0.150
—	—	1.250	31.75	.687	17.45	.860	21.84	1.000	25.40	.250	6.35	.875	22.22							.340	0.154
1.562	39.67	—	—	—	—	—	—	—	—	—	—	—	—	1-10	0.11-1.13	26050	115870	2430	10809	.480	0.218
—	—	1.375	34.92	.812	20.62	.985	25.02	1.125	28.58	.375	9.52	1.000	25.40							.490	0.222
1.687	42.85	—	—	—	—	—	—	—	—	—	—	—	—	1-10	0.11-1.13	34500	153456	2810	12499	.730	0.331
—	—	1.625	41.28	.937	23.80	1.110	28.19	1.250	31.75	.375	9.52	1.125	28.58							.740	0.336



ARYT-E, ARYT

Rod End Bearings - Self -Lubricating
3 Piece, High Misalignment, Male & Female

Plating: When specified in materials block, body Cadmium plated all surfaces per AMS-QQ-P-416, Type I, Class 2.

Dimensions: Dimensions apply after plating.

Option: 1. For left hand threads add "L" to prefix. Examples: ARYTL4E or ARYTL4.

2. For keyway or keyslot options, add suffix "W" to part number.

3. For "J" from threads per MIL-S-8879, add suffix "J" to part number. Examples: ARYT12JW or ARYT12J.

4. To specify CRES 17-4PH race material, add suffix "H" to designation.

Examples: ARYT8ECRH or ARYT8CRH.

Notes: UNF-3A = Male Thread, UNF-3B = Female Thread

MATERIALS

Part No.	Ball	Race	Liner	Body
Basic No.	CRES 440C, 55-62 HRC	CRES 410 Heat Treated	*Teflon/Fabric Permanently Bonded to race I.D.	C.M. STL, Heat Treated Cad. Plated
No. + CR	CRES 440C 55-62 HRC	CRES 410 Heat Treated	*Teflon/Fabric Permanently Bonded to race I.D.	CRES 17-4PH, Heat Treated

NMB Part Number	(B) Bore Diameter		(D) Head Diameter		(W) Ball Width		(H) Body Width		(O) Shoulder Diameter		(F) Ball C/L to End		(E) Thread Size	(Q) Misalignment		
	Inch	mm	Inch	mm	Inch	mm	Inch	mm	Inch	mm	Inch	mm				
	+0.000	+0.000	+0.010	+0.25	+0.000	+0.00	+0.005	+0.13	Ref.	Ref.	Ref.	Ref.	+0.031	+0.79	UNF-3A	
ARYT3E ARYT3	.1900	4.826	.750	19.05	.500	12.70	.220	5.59	.319	8.10	.437	11.10	1.500	38.10	5/16-24	13°
ARYT4E ARYT4	.2500	6.350	1.000	25.40	.593	15.06	.265	6.73	.390	9.91	.593	15.06	1.938	49.22	3/8-24	23°
ARYT5E ARYT5	.3125	7.938	1.125	28.58	.813	20.65	.355	9.02	.512	13.00	.781	19.84	2.125	53.98	7/16-20	22°
ARYT6E ARYT6	.3750	9.525	1.125	28.58	.813	20.65	.355	9.02	.512	13.00	.781	19.84	2.125	53.98	7/16-20	22°
ARYT7E ARYT7	.4375	11.112	1.312	33.32	.875	22.22	.355	9.02	.618	15.70	.875	22.22	2.438	61.93	1/2-20	21°
ARYT8E ARYT8	.5000	12.700	1.500	38.10	.937	23.80	.411	10.44	.730	18.54	1.000	25.40	2.625	66.68	5/8-18	19°
ARYT10E ARYT10	.6250	15.875	1.7500	44.45	1.200	30.48	.577	14.66	.856	21.74	1.250	31.75	2.875	73.02	3/4-16	19°
ARYT12E ARYT12	.7500	19.050	2.000	50.80	1.280	32.51	.630	16.00	.970	24.64	1.375	34.92	3.375	85.72	7/8-14	18°
ARYT14E ARYT14	.8750	22.225	2.200	55.88	1.400	35.56	.635	16.13	1.140	28.96	1.531	38.89	3.750	95.25	7/8-14	17°
ARYT16E ARYT16	1.000	25.400	2.750	69.85	1.875	47.62	.845	21.46	1.278	32.46	1.875	47.62	4.125	104.78	1 1/4-12	20°
ARYT20E ARYT20	1.2500	31.750	3.125	79.38	1.875	47.62	1.015	25.78	1.523	38.68	2.250	57.15	5.000	127.00	1 1/4-12	20°

* A trade name of E.I. duPont de Nemours & Co., Inc.

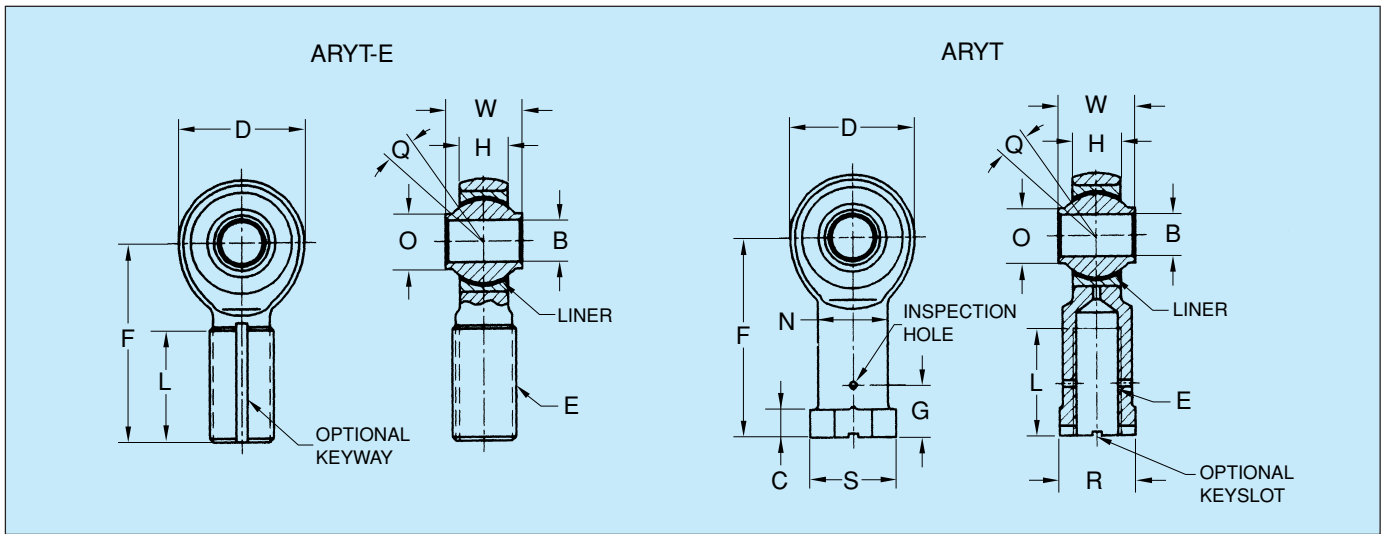

(L)		(N)		(R)		(S)		(C)		(G)		No		Limit Static		Approx.	
Thread Length		Shank Diameter		Wrench Flat		Flange Diameter		Flange Thickness		Drill C/L to End		Load Rotational Breakaway Torque		Radial Load		Weight	
Inch	mm	Inch	mm	Inch	mm	Inch	mm	Inch	mm	Inch	mm	In-lb	N-m	lbs	N	lbs	kg
+0.062	+1.57	+0.010	+0.25	+0.002	+0.05	Ref.	Ref.	+0.010	+0.25	Ref.	Ref.						
-0.031	-0.79	-0.010	-0.25	-0.010	-0.25			-0.062	-1.57								
1.000	25.40	—	—	—	—	—	—	—	—	—	—	.5-6	0.06-0.68	4060	18059	.07	0.032
.750	19.05	.437	11.10	.437	11.10	.500	12.70	.250	6.35	.375	9.52					.06	0.027
1.250	31.75	—	—	—	—	—	—	—	—	—	—	1-15	0.11-1.70	7040	31314	.11	0.050
.937	23.80	.562	14.27	.562	14.27	.625	15.88	.250	6.35	.437	11.10					.11	0.050
1.375	34.92	—	—	—	—	—	—	—	—	—	—	1-15	0.11-1.70	8260	36740	.16	0.073
1.062	26.97	.625	15.88	.625	15.88	.688	17.48	.250	6.35	.500	12.70					.18	0.082
1.375	34.92	—	—	—	—	—	—	—	—	—	—	1-15	0.11-1.70	8260	36740	.15	0.068
1.062	26.97	.625	15.88	.625	15.88	.688	17.48	.250	6.35	.500	12.70					.17	0.077
1.500	38.10	—	—	—	—	—	—	—	—	—	—	1-15	0.11-1.70	12420	55244	.25	0.113
1.125	28.58	.750	19.05	.750	19.05	.812	20.62	.250	6.35	.562	14.27					.26	0.118
1.625	41.28	—	—	—	—	—	—	—	—	—	—	1-15	0.11-1.70	17430	77529	.39	0.177
1.500	38.10	.875	22.22	.875	22.22	.938	23.82	.375	9.52	.687	17.45					.40	0.181
1.750	44.45	—	—	—	—	—	—	—	—	—	—	1-15	0.11-1.70	23620	105062	.62	0.281
1.750	44.45	1.000	25.40	1.000	25.40	1.125	28.58	.375	9.52	.812	20.62					.63	0.286
1.875	47.62	—	—	—	—	—	—	—	—	—	—	1-15	0.11-1.70	30550	135886	.90	0.408
1.875	47.62	1.125	28.58	1.125	28.58	1.250	31.75	.500	12.70	.937	23.80					.87	0.395
2.000	50.80	—	—	—	—	—	—	—	—	—	—	1-15	0.11-1.70	31970	142203	1.08	0.490
2.000	50.80	1.125	28.58	1.125	28.58	1.250	31.75	.500	12.70	.937	23.80					1.01	0.458
2.125	53.98	—	—	—	—	—	—	—	—	—	—	1-24	0.11-2.71	59510	264700	2.20	0.998
2.125	53.98	1.688	42.88	1.688	42.88	1.813	46.05	.562	14.27	1.312	33.32					2.31	1.048
2.875	73.02	—	—	—	—	—	—	—	—	—	—	1-24	0.11-2.71	70060	311627	3.10	1.046
3.125	79.38	1.688	42.88	1.688	42.88	1.813	46.05	.562	14.27	1.312	33.32					3.15	1.429



AR-E, AR

Rod End Bearings - Metal to Metal
3 Piece, Male & Female

Radial Clearance: Free running to .002" (0.051mm) MAX
Plating: When specified in materials block, ball spherical diameter and ends are Chrome plated per AMS-QQ-C-320. All external surfaces of race and/or body are cadmium plated per AMS-QQ-P-416. Type I, Class 2.

Dimensions: Dimensions apply after plating.
Option: 1. For left hand threads add "L" to prefix. Examples: ARL3E or ARL3.
2. For "J" from threads per AS8879, add suffix "J" to part number. Examples: AR4ECRJ or AR4CRJ.
3. For keyway or keyslot per NAS 559 add suffix "W" to part number. Examples: AR16ESSW or AR16SSW.
4. If zerk type lubrication fitting is required add suffix "F" to part number. Examples: AR16EF or AR16F.
5. If flush type lubrication fitting is required add suffix "FN" to part number. Examples: AR8ECRPLFN or AR8CRPLFN.

6. For lubrication holes and I.D. groove in ball add suffix "A" to part number. Examples: AR14ESSA or AR14SSA

7. For dry film lubrication, add suffixes to the designation as follows:
-1 = dry film on race I.D.
-2 = dry film on ball bore.
-3 = dry film on ball spherical surface.

These suffixes are used singly or combination. Example: AR3E-1, AR16ESS-13, AR6E-501-123.
Dimensions apply before dry film.

8. Part No. designation as shown furnished with 410 stainless steel race material. To specify 17-4PH stainless steel, add suffix "H" to designation. Example: AR8ECRPLH or AR8CRPLH.

Notes: 1 Load ratings are based on rod ends without lubrication fitting. For load ratings with lubricator please contact NMB office.
2 UNF-3A = Male Thread, UNF-3B = Female Thread

MATERIALS

Part No.	Ball	Race	Body
Basic Part No.	52100 STL. Heat Treated & Chrome Plated	4130 STL. Heat Treated & Cad. Plated	C.M. STL., Heat Treated & Cad. Plated
Part No.+ SS	52100 STL. Heat Treated & Chrome Plated	CRES 410 Heat Treated	C.M. STL. Heat Treated & Cad. Plated
Part No.+ CR	CRES 440C, Heat Treated	CRES 410 Heat Treated	CRES 17-4PH, Heat Treated
Part No.+ CRPL	CRES 440C, Heat Treated & Chrome Plated	CRES 410 Heat Treated	CRES 17-4PH Heat Treated
Part No.+ 501	52100 STL. Heat Treated & Chrome Plated	Aluminum Bronze Cad. Plated	C.M. STL. Heat Treated & Cad. Plated

NMB Part Number	(B) Bore Diameter		(D) Head Diameter		(W) Ball Width		(H) Body Width		(O) Shoulder Diameter		Ball Diameter		(F) Ball C/L to End		(E) Thread Size	(L) Thread Length	
	Inch	mm	Inch	mm	Inch	mm	Inch	mm	Inch	mm	Inch	mm	Inch	mm		Inch	mm
	+0.000	+0.000	+0.010	+0.25	+0.000	+0.00	+0.005	+0.13					+0.010	+0.25	UNF-3A	+0.062	+1.57
	-0.0005	-0.013	-0.010	-0.25	-0.005	-0.13	-0.005	-0.13	Ref.	Ref.	Ref.	Ref.	-0.010	-0.25	UNF-3B	-0.031	-0.79
AR3E	.1900	4.826	.806	20.47	.437	11.10	.337	8.56	.301	7.65	.531	13.49	1.562	39.67	5/16-24	.968	24.59
AR3													1.375	34.92		.750	19.05
AR4E	.2500	6.350	.806	20.47	.437	11.10	.337	8.56	.301	7.65	.531	13.49	1.562	39.67	5/16-24	.968	24.59
AR4													1.469	37.31		.750	19.05
AR5E	.3125	7.938	.900	22.86	.437	11.10	.327	8.31	.401	10.19	.593	15.06	1.875	47.62	5/16-24	1.187	30.15
AR5													1.625	41.28	3/8-24	.875	22.22
AR6E	.3750	9.525	1.025	26.04	.500	12.70	.416	10.57	.471	11.96	.687	17.45	1.938	49.22	3/8-24	1.187	30.15
AR6													1.812	46.02		1.000	25.40
AR7E	.4375	11.112	1.150	29.21	.562	14.27	.452	11.48	.542	13.77	.781	19.84	2.125	53.98	7/16-20	1.281	32.54
AR7													2.000	50.80		1.125	28.58
AR8E	.5000	12.700	1.337	33.96	.625	15.88	.515	13.08	.612	15.54	.875	22.22	2.438	61.93	1/2-20	1.468	37.29
AR8													2.250	57.15		1.250	31.75
AR10E	.6250	15.875	1.525	38.74	.750	19.05	.577	14.66	.752	19.10	1.062	26.97	2.625	66.68	5/8-18	1.562	39.67
AR10													2.500	63.50		1.375	43.92
AR12E	.7500	19.050	1.775	45.08	.875	22.22	.640	16.26	.892	22.66	1.250	31.75	2.875	73.02	3/4-16	1.687	42.85
AR12													2.875	73.02		1.625	41.28
AR14E	.8750	22.225	2.025	51.44	.875	22.22	.765	19.43	1.061	26.95	1.375	34.92	3.375	85.72	7/8-14	2.000	50.80
AR14													3.375	85.72		1.875	47.62
AR16E	1.0000	25.400	2.775	70.48	1.375	34.92	1.015	25.78	1.275	32.38	1.875	47.62	4.125	104.78	1 1/4-12	2.343	59.51
AR16													4.125	104.78		2.125	53.98

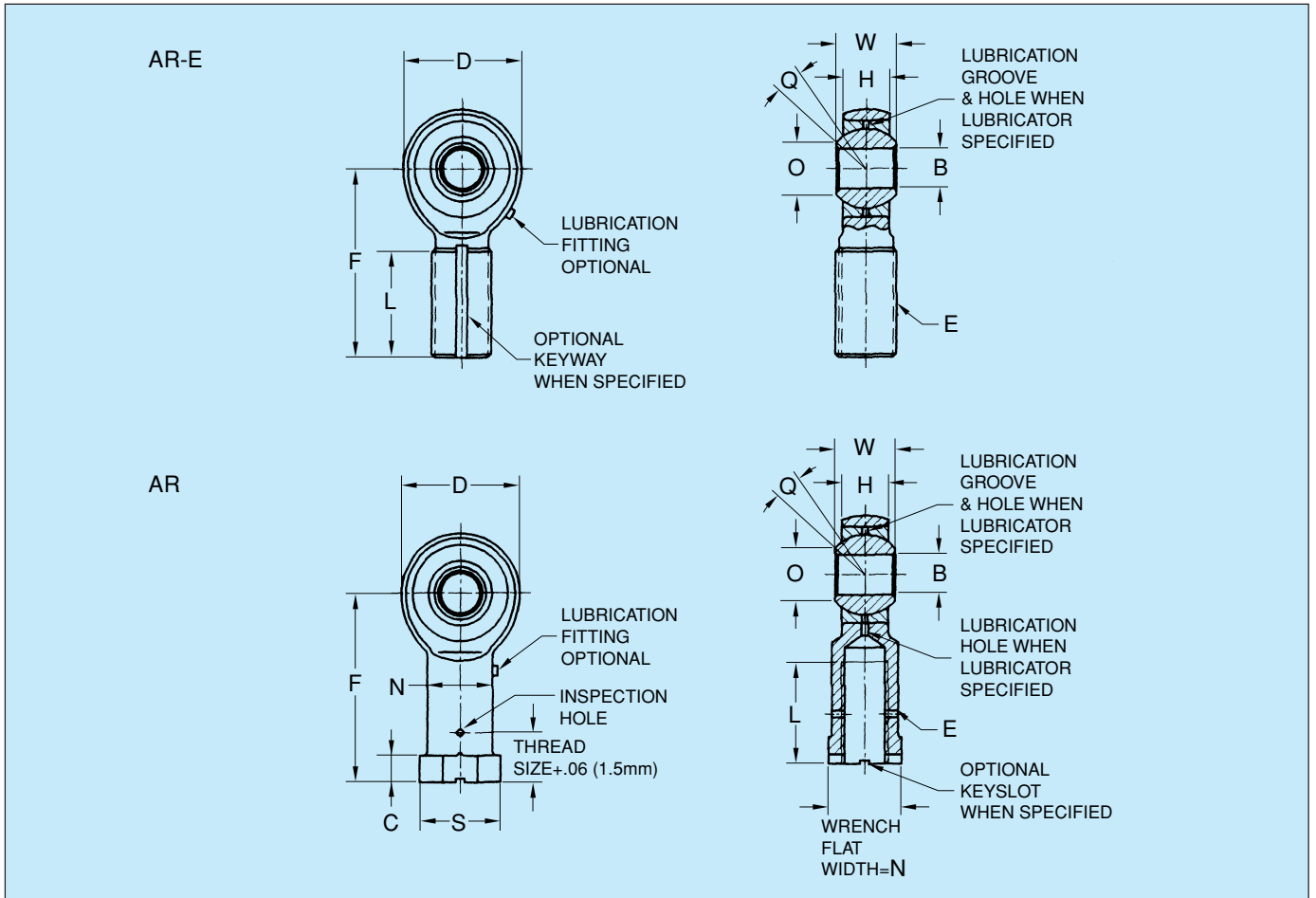

(Q) Misalign- ment	(N) Shank Diameter		(S) Flange Diameter		(C) Flange Thickness		Static Radial		Ultimate Load		Approx. Weight	
	Inch	mm	Inch	mm	Inch	mm	lbs	N	lbs	N	lbs	kg
Ref.	Ref.	Ref.	Ref.	Ref.	+0.10 -0.062	+0.25 -1.57						
16°	.422	10.72	.500	12.70	.188	4.78	6150	27355	6150	27355	.07 .08	0.03 0.04
16°	.422	10.72	.500	12.70	.188	4.78	7540	33537	7540	33537	.07 .08	0.03 0.04
14°	.485	12.32	.580	14.73	.250	6.35	7950	35361	7950	35361	.10	0.05
9°	.547	13.89	.660	16.76	.250	6.35	10950	48705	10950	48705	.13 .16	0.06 0.07
11°	.610	15.49	.720	18.29	.250	6.35	14000	62272	14000	62272	.18 .21	0.08 0.10
9°	.735	18.67	.880	22.35	.250	6.35	23400	104083	21200	94297	.27 .32	0.12 0.15
12°	.860	21.84	1.020	25.91	.375	9.52	26100	116092	26100	116092	.42 .48	0.19 0.22
14°	.985	25.02	1.160	29.46	.375	9.52	34500	153456	34500	153456	.63 .87	0.29 0.39
6°	1.110	28.19	1.300	33.02	.500	12.70	38400	170803	38400	170803	.96 .95	0.44 0.43
14°	1.688	42.88	2.020	51.31	.563	14.30	92100	409660	92100	409660	2.54 2.71	1.15 1.23



ARH-E, ARH

Rod End Bearings, Metal to Metal
3 Piece, Heavy Duty, Male & Female

Radial clearance: Free running to .002" (0.051mm) MAX
Plating: When specified in materials block, ball spherical diameter and ends are Chrome plated per AMS-QQ-C-320. All external surfaces of race and/or body are Cadmium plated per AMS-QQ-P-416. Type I, Class 2.

Dimensions: Dimensions apply after plating.
Option: 1. For left hand threads add "L" to prefix. Examples: ARHL4E or ARHL4.
2. For "J" from threads per AS8879, add suffix "J" to part number. Examples: ARH5ECRJ or ARH5CRJ.
3. For keyway or keyslot per NAS 559 add suffix "W" to part number. Examples: ARH8ESSW or ARH8SSW.
4. If zerk type lubrication fitting is required add suffix "F" to part number. Examples: ARH10EF or ARH10F.
5. If flush type lubrication fitting is required add suffix "FN" to part number. Examples: ARH7ECRPLFN or ARH7CRPLFN.
6. For lubrication holes and I.D. groove in ball add suffix "A" to part number. Examples: ARH12ESSA or ARH12SSA.
7. For dry film lubrication, add suffixes to the designation as follows:
-1 = dry film on race I.D.
-2 = dry film on ball bore.
-3 = dry film on ball spherical surface.
These suffixes are used singly or combination. Example: ARH6E-1, ARH8SS-13, ARH10-501-123 Dimensions apply before dry film.

⚠ Part No. designation as shown furnished with 410 stainless steel race material. To specify 17-4PH stainless steel, add suffix "H" to designation. Example: ARH8ECRPLH.

Notes: 1 Load ratings are based on rod ends without lubrication fitting. For load ratings with lubricator please contact NMB office.
2 UNF-3A = Male Thread, UNF-3B = Female Thread

MATERIALS

Part No.	Ball	Race	Body
Basic Part No.	52100 STL. Heat Treated & Chrome Plated	4130 STL. Heat Treated & Cad. Plated	C.M. STL., Heat Treated & Cad. Plated
Part No.+ SS	52100 STL. Heat Treated & Chrome Plated	CRES 410 Heat Treated ⚠	C.M. STL. Heat Treated & Cad. Plated
Part No.+ CR	CRES 440C, Heat Treated	CRES 410 Heat Treated ⚠	CRES 17-4PH, Heat Treated
Part No.+ CRPL	CRES 440C, Heat Treated & Chrome Plated	CRES 410 Heat Treated ⚠	CRES 17-4PH Heat Treated
Part No.+ 501	52100 STL. Heat Treated & Chrome Plated	Aluminum Bronze Cad. Plated	C.M. STL. Heat Treated & Cad. Plated

NMB Part Number	(B) Bore Diameter		(D) Head Diameter		(W) Ball Width		(H) Body Width		(O) Shoulder Diameter		Ball Diameter		(F) Ball C/L to End		(E) Thread Size	(L) Thread Length	
	Inch	mm	Inch	mm	Inch	mm	Inch	mm	Inch	mm	Inch	mm	Inch	mm		Inch	mm
	+0.000	+0.000	+0.010	+0.25	+0.000	+0.00	+0.005	+0.13					+0.010	+0.25	UNF-3A	+0.062	+1.57
	-0.0005	-0.013	-0.010	-0.25	-0.005	-0.13	-0.005	-0.13	Ref.	Ref.	Ref.	Ref.	-0.010	-0.25	UNF-3B	-0.031	-0.79
ARH4E ARH4	.2500	6.350	.806	20.47	.375	9.52	.337	8.56	.375	9.52	.531	13.49	1.562	39.67	5/16-24	.968	24.59
													1.469	37.31		.750	19.05
ARH5E ARH5	.3125	7.938	.900	22.86	.437	11.10	.327	8.31	.401	10.19	.593	15.06	1.875	47.62	3/8-24	1.187	30.15
													1.625	41.28		.875	22.22
ARH6E ARH6	.3750	9.525	1.025	26.04	.500	12.70	.416	10.57	.471	11.96	.687	17.45	1.938	49.23	7/16-20	1.187	30.15
													1.812	46.02		1.000	25.40
ARH7E ARH7	.4375	11.112	1.150	29.21	.562	14.27	.452	11.48	.542	13.77	.781	19.84	2.125	53.98	1/2-20	1.281	32.54
													2.000	50.80		1.125	28.58
ARH8E ARH8	.5000	12.700	1.337	33.96	.625	15.88	.515	13.08	.612	15.54	.875	22.22	2.438	61.93	5/8-18	1.468	37.29
													2.250	57.15		1.250	31.75
ARH10E ARH10	.6250	15.875	1.525	38.74	.750	19.05	.577	14.66	.752	19.10	1.062	26.97	2.625	66.68	3/4-16	1.562	39.67
													2.500	63.50		1.375	34.92
ARH12E ARH12	.7500	19.050	1.775	45.08	.875	22.22	.640	16.26	.892	22.66	1.250	31.75	2.875	73.02	7/8-14	1.687	42.85
													2.875	73.02		1.625	41.28

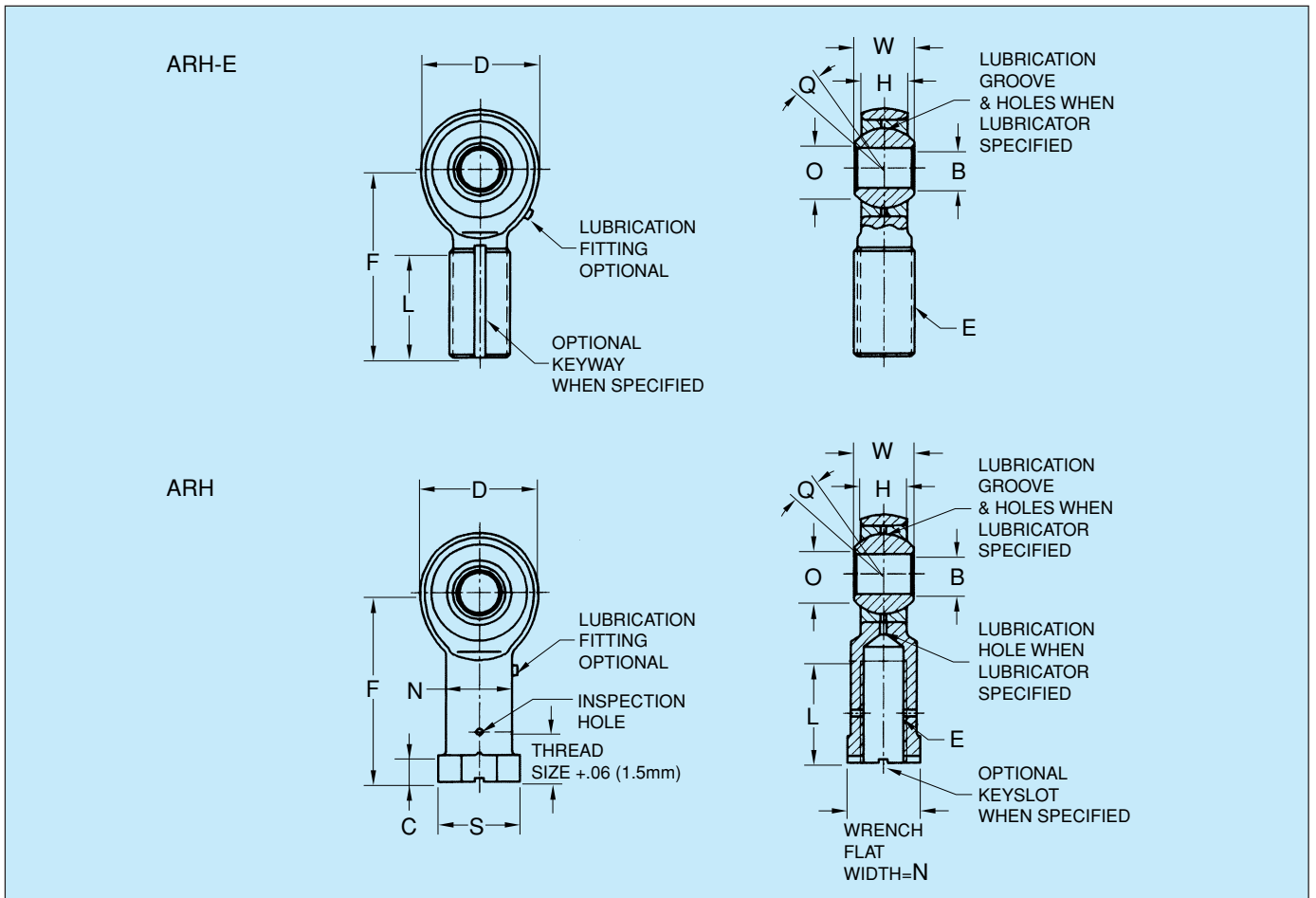

(Q) Misalign- ment	(N) Shank Diameter		(S) Flange Diameter		(C) Flange Thickness		*Static Radial Ultimate Load Steel Race		Bronze Race		Approx. Weight	
	Inch	mm	Inch	mm	Inch	mm	lbs	N	lbs	N	lbs	kg
Ref.	Ref.	Ref.	Ref.	Ref.	+0.10 -0.062	+0.25 -1.57						
5°	—	—	—	—	—	—	7540	33538	7540	33538	.067 .084	0.030 0.038
14°	.485	12.32	.562	14.27	.188	4.78	9200	40921	8800	39142	.095 .102	0.043 0.046
9°	.610	15.49	.687	17.45	.250	6.35	10950	48705	10950	48706	.140 .160	0.064 0.073
10°	.735	18.67	.875	22.22	.250	6.35	14000	62272	14000	62272	.210 .230	0.095 0.104
9°	.860	21.84	1.000	25.40	.250	6.35	23400	104083	21200	94298	.330 .340	0.150 0.154
12°	.985	25.02	1.125	28.58	.375	9.52	26100	116092	26100	116093	.480 .490	0.218 0.222
13°	1.110	28.19	1.250	31.75	.375	9.52	34500	153456	34500	153456	.730 .740	0.331 0.336



ARYM, ARYF

Rod End Bearings - Metal to Metal
3 Piece, High Misalignment, Male & Female

Radial clearance: Free running to .002" (0.051mm) MAX
Plating: When specified in materials block, ball spherical diameter and ends are Chrome plated per AMS-QQ-C-320. All external surfaces of race and/or body are Cadmium plated per AMS-QQ-P-416. Type I, Class 2. Dimensions apply after plating.

Dimensions:
Option:

- For left hand threads add "L" to prefix. Examples: ARYML3 or ARYFL3.
- For "J" from threads per AS8879, add suffix "J" to part number. Examples: ARYM4CRJ or ARYF4CRJ.
- For keyway or keyslot per NAS 559 add suffix "W" to part number. Examples: ARYM16SSW or ARYF-16SSW.
- If zerk type lubrication fitting is required add suffix "F" to part number. Example: ARYM20F or ARYF20F.
- If flush type lubrication fitting is required add suffix "FN" to part number. Example: ARYM8CRPLFN or ARYF8CRPLFN.
- For lubrication holes and I.D. groove in ball add suffix "A" to part number. Example: ARYM14SSA or ARYF14SSA.
- For dry film lubrication, add suffixes to the designation as follows:
 - 1 = dry film on race I.D.
 - 2 = dry film on ball bore.
 - 3 = dry film on ball spherical surface.

These suffixes are used singly or combination. Example: ARYF3-1, ARYM20SS-13, ARYF6-501-123
Dimensions apply before dry film.

Part No. designation as shown furnished with 410 stainless steel race material. To specify 17-4PH stainless steel, add suffix "H" to designation. Example: ARYM8CRPLH or ARYF8CRPLH.

Notes: Load ratings are based on rod ends without lubrication fitting. For load ratings with lubricator please contact NMB office.
2 UNF-3A = Male Thread, UNF-3B = Female Thread

MATERIALS

Part No.	Ball	Race	Body
Basic Part No.	52100 STL. Heat Treated & Chrome Plated	4130 STL. Heat Treated & Cad. Plated	C.M. STL., Heat Treated & Cad. Plated
Part No.+ SS	52100 STL. Heat Treated & Chrome Plated	CRES 410 Heat Treated	C.M. STL. Heat Treated & Cad. Plated
Part No.+ CR	CRES 440C, Heat Treated	CRES 410 Heat Treated	CRES 17-4PH, Heat Treated
Part No.+ CRPL	CRES 440C, Heat Treated & Chrome Plated	CRES 410 Heat Treated	CRES 17-4PH Heat Treated
Part No.+ 501	52100 STL. Heat Treated & Chrome Plated	Aluminum Bronze Cad. Plated	C.M. STL. Heat Treated & Cad. Plated

NMB Part Number	(B) Bore Diameter		(D) Head Diameter		(W) Ball Width		(H) Body Width		(O) Shoulder Diameter		Ball Diameter		(F) Ball C/L to End		(E) Thread Size	(L) Thread Length	
	Inch	mm	Inch	mm	Inch	mm	Inch	mm	Inch	mm	Inch	mm	Inch	mm		Inch	mm
	+0.000	+0.000	+0.010	+0.25	+0.000	+0.00	+0.005	+0.13					+0.031	+0.79	UNF-3A	+0.062	+1.57
	-0.0005	-0.013	-0.010	-0.25	-0.005	-0.13	-0.005	-0.13	Ref.	Ref.	Ref.	Ref.	-0.031	-0.79	UNF-3B	-0.031	-0.79
ARYM3 ARYF3	.1900	4.826	.750	19.05	.500	12.70	.220	5.59	.319	8.10	.437	11.10	1.500	38.10		1.000	25.40
													1.375	34.92		.750	19.05
ARYM4 ARYF4	.2500	6.350	1.000	25.40	.593	15.06	.265	6.73	.390	9.91	.593	15.06	1.938	49.23		1.250	31.75
													1.625	41.28		.937	23.80
ARYM5 ARYF5	.3125	7.938	1.125	28.58	.813	20.65	.355	9.02	.512	13.00	.781	19.84	2.125	53.98		1.375	34.92
													1.812	46.02		1.062	26.97
ARYM6 ARYF6	.3750	9.525	1.125	28.58	.813	20.65	.355	9.02	.512	13.00	.781	19.84	2.125	53.98		1.375	34.92
													1.812	46.02		1.062	26.97
ARYM7 ARYF7	.4375	11.112	1.312	33.32	.875	22.22	.355	9.02	.618	15.70	.875	22.22	2.438	61.93		1.500	38.10
													2.125	53.98		1.125	28.58
ARYM8 ARYF8	.5000	12.700	1.500	38.10	.937	23.80	.411	10.44	.730	18.54	1.000	25.40	2.625	66.68		1.625	41.27
													2.625	66.68		1.500	38.10
ARYM10 ARYF10	.6250	15.875	1.750	44.45	1.200	30.48	.577	14.66	.856	21.74	1.250	31.75	2.875	73.02		1.750	44.45
													2.875	73.02		1.750	44.45
ARYM12 ARYF12	.7500	19.050	2.000	50.80	1.280	32.51	.630	16.00	.970	24.64	1.375	34.92	3.375	85.72		1.875	47.62
													3.375	85.72		1.875	47.62
ARYM14 ARYF14	.8750	22.225	2.200	55.88	1.400	35.56	.635	16.13	1.140	28.96	1.531	38.89	3.750	95.25		2.000	50.80
													3.750	95.25		2.000	50.80
ARYM16 ARYF16	1.000	25.400	2.750	69.85	1.875	47.62	.845	21.46	1.278	32.46	1.875	47.62	4.125	104.78		2.125	53.98
													4.125	104.78		2.125	53.98
ARYM20 ARYF20	1.250	31.750	3.125	79.38	1.875	47.62	1.015	25.78	1.523	38.68	2.250	57.15	5.000	127.00		2.875	73.02
													5.000	127.00		3.125	79.38

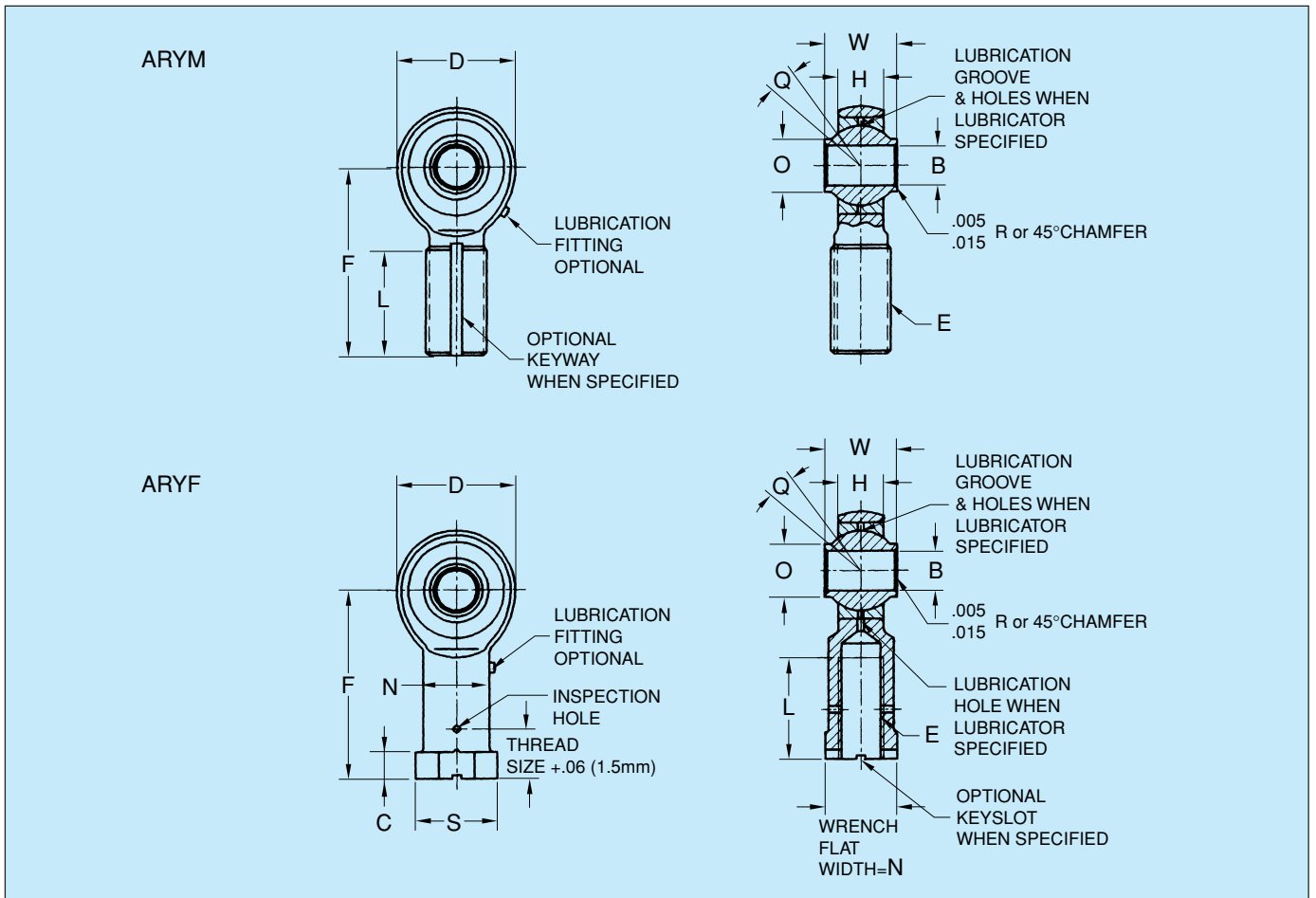

	(Q) Misalign-ment		(N) Shank Diameter		(S) Flange Diameter		(C) Flange Thickness		▲ Static Radial Ultimate Load		Approx. Weight			
	Inch	mm	Inch	mm	Inch	mm	Inch	mm	lbs	N	lbs	N	lbs	kg
Ref.	Ref.	Ref.	Ref.	Ref.	Ref.	Ref.	+.010	+0.25						
							-.062	-1.57						
13°	—	—	—	—	—	—	—	—	4830	21484	4830	21484	.07	0.03
	.437	11.10	.500	12.70	.250	6.35							.06	0.03
23°	—	—	—	—	—	—	—	—	8650	38475	7850	34917	.11	0.05
	.562	14.27	.625	15.88	.250	6.35							.11	0.05
22°	—	—	—	—	—	—	—	—	9050	40254	9050	40254	.16	0.07
	.625	15.88	.688	17.48	.250	6.35							.18	0.08
22°	—	—	—	—	—	—	—	—	9050	40254	9050	40254	.15	0.07
	.625	15.88	.688	17.48	.250	6.35							.17	0.08
21°	—	—	—	—	—	—	—	—	14100	62717	14100	62717	.25	0.11
	.750	19.05	.812	20.62	.250	6.35							.26	0.12
19°	—	—	—	—	—	—	—	—	19800	88070	19800	88070	.39	0.18
	.875	22.22	.938	23.83	.375	9.52							.40	0.18
19°	—	—	—	—	—	—	—	—	26500	117872	26500	117872	.62	0.28
	1.000	25.40	1.125	28.58	.375	9.52							.63	0.29
18°	—	—	—	—	—	—	—	—	34200	152122	33300	148118	.90	0.41
	1.125	28.58	1.250	31.75	.500	12.70							.87	0.39
17°	—	—	—	—	—	—	—	—	36400	161907	36200	161018	1.08	0.49
	1.125	28.58	1.250	31.75	.500	12.70							1.01	0.46
20°	—	—	—	—	—	—	—	—	66500	295792	54000	240192	2.20	1.00
	1.688	42.88	1.813	46.05	.562	14.27							2.31	1.05
20°	—	—	—	—	—	—	—	—	80000	355840	77200	343386	3.10	1.41
	1.688	42.88	1.813	46.05	.562	14.27							3.15	1.43



ARB-E, ARB

Rod End Bearings - Metal to Metal
3 Piece, Male & Female

Radial clearance: Free running to .002" (0.051mm) MAX
Plating: When specified in materials block, ball spherical diameter and ends are Chrome plated per AMS-QQ-C-320. All external surfaces of race and/or body are Cadmium plated per AMS-QQ-P-416. Type I, Class 2.

Dimensions: Dimensions apply after plating.
Option: 1. For left hand threads add "L" to prefix. Examples: ARBL3E or ARBML3.
2. For "J" from threads per AS8879, add suffix "J" to part number. Examples: ARBL3J or ARBM4J.
3. For keyway or keyslot per NAS 559 add suffix "W" to part number. Examples: ARBH4EW or ARBH5W.
4. If zerk type lubrication fitting is required add suffix "F" to part number. Example: ARBM4EF or ARBH5F.
5. If flush type lubrication fitting is required add suffix "FN" to part number. Examples: ARBM4ESSFN or ARBM3CRFN.
6. For lubrication holes and I.D. groove in ball add suffix "A" to part number. Example: ARBH4ESA or ARBH5SA.
7. For dry film lubrication, add suffixes to the designation as follows:
-1 = dry film on race I.D.
-2 = dry film on ball bore.
-3 = dry film on ball spherical surface.
These suffixes are used singly or combination. Example: ARBL3E-1, ARBM4-13, ARBH5ECRPL-123
Dimensions apply before dry film.

MATERIALS

Part No.	Ball	Race	Body
Basic Part No.	52100 STL. Heat Treated & Chrome Plated	Aluminum Bronze	4130 STL. Heat Treated Cad. Plated
Part No.+ S	52100 STL. Heat Treated & Chrome Plated	4130 STL. Heat Treated & Cad. Plated	4130 STL. Heat Treated & Cad. Plated
Part No.+ SS	51200 STL. Heat Treated & Chrome Plated	CRES 410 Heat Treated	4130 STL. Heat Treated Cad. Plated
Part No.+ CR	CRES 440C Heat Treated	CRES 410 Heat Treated	CRES 17-4PH Heat Treated
Part No.+ CRPL	CRES 440 Heat Treated & Chrome Plated	CRES 410 Heat Treated	CRES 17-4PH Heat Treated

⚠ Part No. designation as shown furnished with 410 stainless steel race material. To specify 17-4PH stainless steel, add suffix "H" to designation. Examples: ARBM4ECRH, ARBHL4CRH.

Notes: 1 Load ratings are based on rod ends without lubrication fitting. For load ratings with lubricator please contact NMB office.
2 UNF-3A = Male Thread, UNF-3B = Female Thread.
3 Lubrication fittings not available on ARBL3E & ARBL3.

NMB Part Number	(B) Bore Diameter		(D) Head Diameter		(W) Ball Width		(H) Body Width		(O) Shoulder Diameter		Ball Diameter		(F) Ball C/L to End		(E) Thread Size	(L) Thread Length	
	Inch	mm	Inch	mm	Inch	mm	Inch	mm	Inch	mm	Inch	mm	Inch	mm		Inch	mm
	+0.015	+0.038			+0.000	+0.000	+0.010	+0.025					+0.031	+0.079	UNF-3A		
	-0.0005	-0.013	MAX	MAX	-0.005	-0.13	-0.010	-0.25	Ref.	Ref.	Ref.	Ref.	-0.031	-0.079	UNF-3B	MIN	MIN
ARBL3E ARBL3	.1900	4.826	.562	14.27	.250	6.35	.187	4.750	.235	5.97	.343	8.71	1.000	25.40	1/4-28 10-32	.593	15.06 12.70
ARBM3E ARBM3	.1900	4.826	.812	20.62	.437	11.10	.328	8.33	.302	7.67	.531	13.49	1.375	34.92	5/16-24 1/4-28	.718	18.24
ARBM4E ARBM4	.2500	6.350	.812	20.62	.437	11.10	.328	8.33	.302	7.67	.531	13.49	1.375	34.92	5/16-24 1/4-28	.718	18.24
ARBH4E ARBH4	.2500	6.350	1.093	27.76	.500	12.70	.312	7.92	.425	10.80	.656	16.66	1.750	44.45	3/8-24 5/16-24	.968	24.59 21.41
ARBH5E ARBH5	.3125	7.938	1.093	27.76	.500	12.70	.312	7.92	.425	10.80	.656	16.66	1.750	44.45	7/16-20 5/16-24	.968	24.59 21.41

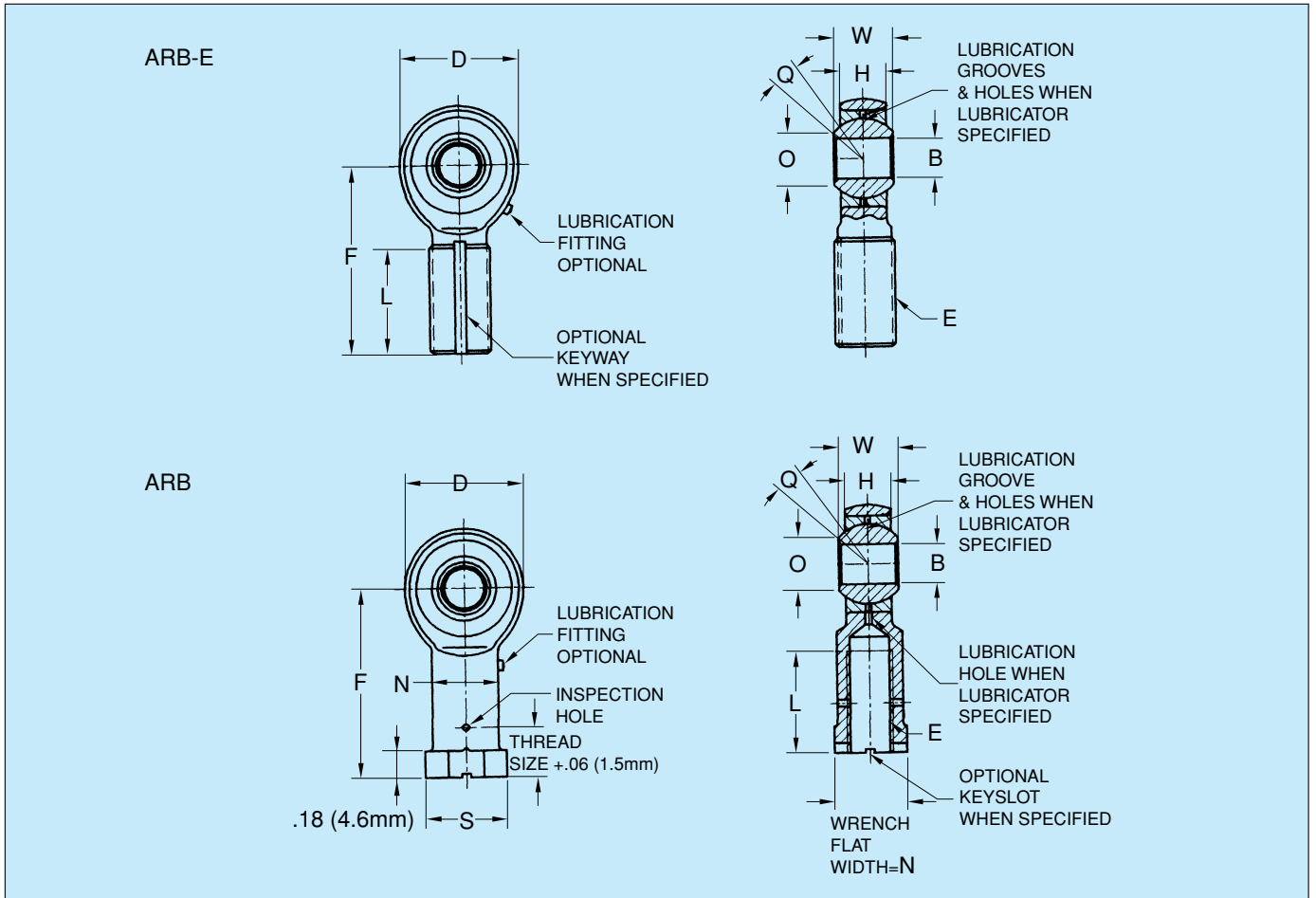

(Q) Misalign- ment	(N) Shank Diameter		(S) Flange Diameter		Static Radial Ultimate Load				Approx. Weight	
	Inch	mm	Inch	mm	Steel Race		Bronze Race		lbs	kg
Ref.	+0.030 -0.030	+0.76 -0.76	+0.030 -0.015	+0.76 -0.38	lbs	N	lbs	N	lbs	kg
13°	—	—	—	—	2750	12232	2750	12232	.02	0.01
	.281	7.14	.343	8.71	2620	11654	2620	11654		
17°	—	—	—	—	6140	27311	6140	27311	.06	0.03
	.375	9.52	.437	11.10	5230	23263	5230	23263		
17°	—	—	—	—	7650	34027	7650	34027	.06	0.03
	.375	9.52	.437	11.10	5230	23263	5230	23263		
21°	—	—	—	—	10650	47371	9900	44035	.13	0.06
	.500	12.70	.562	14.27	7910	35184	7910	35184		
21°	—	—	—	—	14200	63162	9900	44035	.13	0.06
	.500	12.70	.562	14.27	7910	35184	7910	35184		



ABR-M

Ball Bearings Rod Ends, Double Row
MS21151, Male

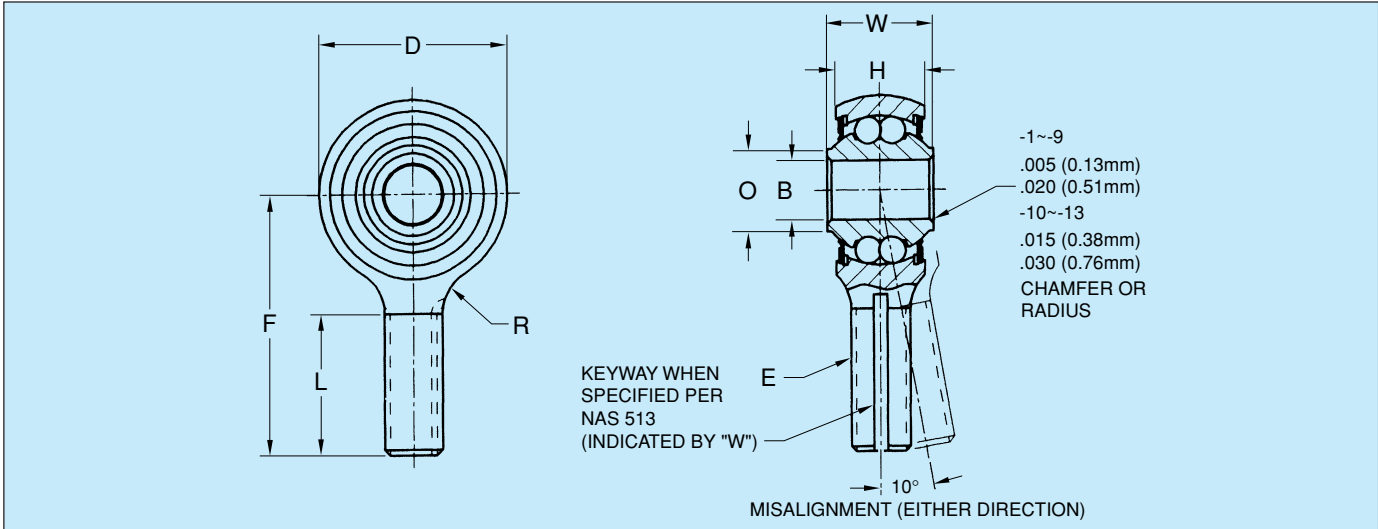

NMB Part Number	(B) Bore Diameter		(D) Head Diameter		(W) Inner Race Width		(H) Body Width		(O) Shoulder Diameter		(F) Inner Race C/L to End		(E) Thread Size	(L) Thread Length		(R) Radius		Approx. Weight		
	Inch	mm	Inch	mm	Inch	mm	Inch	mm	Inch	mm	Inch	mm		Inch	mm	Ref.	Ref.	lbs	kg	
	+0.000	+0.000	+0.010	+0.25	+0.000	+0.00	+0.010	+0.25			+0.010	+0.25		+0.031	+0.79					
	-0.0003	-0.008	-0.010	-0.25	-0.005	-0.13	-0.010	-0.25	MIN	MIN	Size	-0.10	-0.25	UNJF-3A	-0.031	-0.79				
ABRL3M-1	.1900	4.826	.781	19.84	.437	11.10	.328	8.33	.276	7.01	1/8	1.375	34.92	.1900-32L	.750	19.05	.422	10.72	.04	0.018
ABR3M-2	.1900	4.826	.781	19.84	.437	11.10	.328	8.33	.276	7.01	1/8	1.375	34.92	.1900-32	.750	19.05	.422	10.72	.04	0.018
~ABR3M-3	.1900	4.826	.969	24.61	.500	12.70	.407	10.34	.299	7.59	1/8	2.031	51.59	.3750-24	1.313	33.35	.500	12.70	.05	0.023
ABR3M-4	.1900	4.826	.781	19.84	.437	11.10	.328	8.33	.276	7.01	1/8	1.375	34.92	.3750-24	.750	19.05	.390	9.91	.05	0.023
ABRL3M-5	.1900	4.826	.781	19.84	.437	11.10	.328	8.33	.276	7.01	1/8	1.375	34.92	.3750-24L	.750	19.05	.390	9.91	.05	0.023
~ABR3M-6	.1900	4.826	.781	19.84	.500	12.70	.438	11.13	.307	7.80	1/8	1.812	46.02	.2500-28	.938	23.83	.562	14.27	.10	0.045
ABR3M-7	.1900	4.826	.781	19.84	.437	11.10	.328	8.33	.276	7.01	1/8	1.563	39.70	.2500-28	1.000	25.40	.344	8.74	.05	0.023
ABR4M-8	.2500	6.350	.938	23.83	.593	15.06	.438	11.13	.340	8.64	5/32	1.875	47.62	.3750-24	1.125	28.58	.469	11.91	.10	0.045
ABRL4M-9	.2500	6.350	.938	23.83	.593	15.06	.438	11.13	.340	8.64	5/32	1.875	47.62	.3750-24L	1.125	28.58	.469	11.91	.10	0.045
~ABR5M-10	.3125	7.938	1.250	31.75	.870	22.10	.656	16.66	.501	12.73	3/16	2.438	61.93	.3750-24	1.563	39.70	.500	12.70	.24	0.109
~ABR5M-11	.3125	7.938	1.250	31.75	.870	22.10	.656	16.66	.501	12.73	3/16	2.438	61.93	.4375-20	1.563	39.70	.500	12.70	.24	0.109
~ABR5M-12	.3125	7.938	1.250	31.75	.870	22.10	.656	16.66	.501	12.73	3/16	2.438	61.93	.6250-18	1.563	39.70	.500	12.70	.24	0.109
~ABR10M-13	.6250	15.875	2.000	50.80	1.125	28.58	.938	23.83	.875	22.23	9/32	2.750	69.85	.6250-18	1.500	38.10	.500	12.70	.71	0.322

Notes:

- Radial Clearance: .0004" (0.010mm) MAX. Axial Clearance: .003" (0.08mm) MAX.
- Surface Finish: Balls and Raceways - 8 microinches AA (0.2µmRa), Shank - 63 microinches AA (1.6µmRa).
- Lubrication: Prepacked with grease per MIL-PRF-81322. If grease per MIL-PRF-23827 is required, add suffix "G" to part number. EXAMPLE: ABR4M-8G.
- Plating: Exposed surfaces as mounted are Cadmium plated. Dimensions are met after Plating.
- All dimensions, materials and configurations conform to requirements of MS spec. Consult QPL MIL-B-6039 for NMB approvals to MS21151.

MATERIALS

Inner Race & Balls	Seal Retainer	Seal~	Body ④
52100 STL. 60-66 HRC	300 Series CRES	Teflon*	8620 STL. 90KSI MIN Tensile Strength Raceway Carburized to 59-63 HRC MIN

~ Removeable

NMB Part Number	Radial Limit Load†		Axial Limit Load†		Dynamic Radial Load Rating Average Life of 10,000 Complete 90° Cycles†	
	lbs	N	lbs	N	lbs	N
ABRL3M-1, ABR3M-2	1000	4448	200	890	1000	4448
ABR3M-3	1200	5338	240	1068	1200	5338
ABR3M-4, -6, -7 ABRL3M-5	1000	4448	200	890	1000	4448
ABR4M-8, ABRL4M-9	1720	7651	345	1535	1720	7651
ABR5M-10, -11, -12	2920	12988	585	2602	2920	12988
ABR10M-13	7090	31536	1420	6316	6160	27400

* A trademark of E.I. duPont de Nemours & Co., Inc.

† LOAD RATINGS are for operation up to 250°F (121°C). For operation above 250°F (121°C), reduce ratings by 20%.

‡ RADIAL FRACTURE LOAD is 1.5 times radial limit load - AXIAL FRACTURE LOAD is 1.5 times axial limit load.

ABR-F

Ball Bearings Rod Ends, Double Row
MS21153, Female

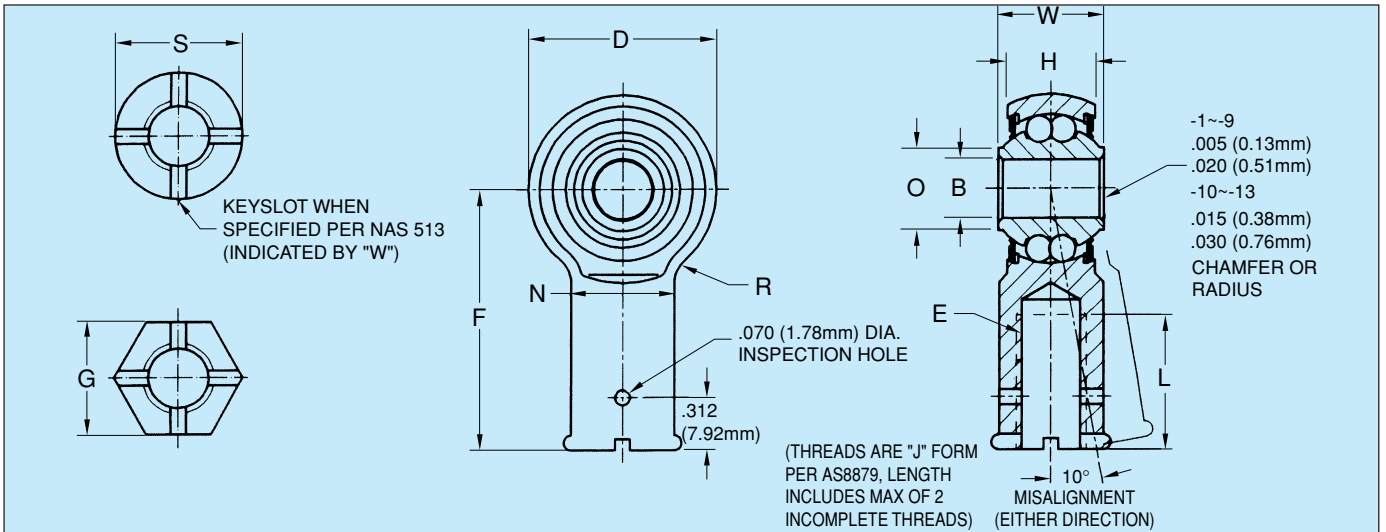

NMB Part Number	(B) Bore Diameter		(D) Head Diameter		(W) Inner Race Width		(H) Body Width		(O) Shoulder Diameter		(F) Length C/L to End		(E) Thread Size	(L) Thread Length		(N) Shank Diameter		(R) Radius		(S) Bead Diameter		(G) Hex Diameter		Approx. Weight		
	Inch	mm	Inch	mm	Inch	mm	Inch	mm	Inch	mm	Inch	mm		Inch	mm	Inch	mm	Inch	mm	Inch	mm	Inch	mm	lbs	kg	
	+0.000	+0.000	+0.010	+0.25	+0.000	+0.00	+0.010	+0.25			+0.010	+0.25		+0.031	+0.79	+0.010	+0.25			+0.10	+0.25	+0.010	+0.25			
	-0.003	-0.008	-0.010	-0.25	-0.005	-0.13	-0.010	-0.25	MIN	MIN	Size	-0.010	-0.25	UNJF-3B	-0.031	-0.79	-0.010	-0.25	Ref.	Ref.	-0.10	-0.25	-0.010	-0.25		
ABR3F-1	.1900	4.826	.781	19.84	.437	11.10	.328	8.33	.276	7.01	1/8	1.375	34.92	.2500-28	.750	19.05	.375	9.52	.390	9.91	.438	11.12	—	—	.05	0.023
ABR3F-2	.1900	4.826	.781	19.84	.437	11.10	.328	8.33	.276	7.01	1/8	1.375	34.92	.3125-24	.750	19.05	.438	11.13	.390	9.91	—	—	.438	11.12	.06	0.027
ABR3F-3	.1900	4.826	.781	19.84	.500	12.70	.328	8.33	.276	7.01	1/8	1.375	34.92	.2500-28	.750	19.05	.375	9.52	.390	9.91	.438	11.12	—	—	.06	0.027
ABRL3F-4	.1900	4.826	.781	19.84	.500	12.70	.328	8.33	.276	7.01	1/8	1.375	34.92	.2500-28L	.750	19.05	.375	9.52	.390	9.91	.438	11.12	—	—	.06	0.027
ABRL3F-5	.1900	4.826	.781	19.84	.437	11.10	.328	8.33	.276	7.01	1/8	1.375	34.92	.2500-28L	.750	19.05	.375	9.52	.390	9.91	.438	11.12	—	—	.05	0.023
ABR4F-6	.2500	6.350	.938	23.83	.593	15.06	.438	11.13	.340	8.64	5/32	1.469	37.31	.3125-24	.750	19.05	.438	11.13	.468	11.89	—	—	.438	11.12	.07	0.032
ABRL4F-7	.2500	6.350	.938	23.83	.593	15.06	.438	11.13	.340	8.64	5/32	1.469	37.31	.3125-24L	.750	19.05	.438	11.13	.468	11.89	—	—	.438	11.12	.07	0.032
ABR4F-8	.2500	6.350	.938	23.83	.593	15.06	.438	11.13	.340	8.64	5/32	1.875	47.62	.4375-20	1.125	28.58	.625	15.88	.468	11.89	—	—	—	—	.16	0.072
ABRL4F-9	.2500	6.350	.938	23.83	.593	15.06	.438	11.13	.340	8.64	5/32	1.875	47.62	.4375-20L	1.125	28.58	.625	15.88	.468	11.89	—	—	—	—	.16	0.072
~ABR5F-10	.3125	7.938	1.250	31.75	.870	22.10	.656	16.66	.501	12.73	3/16	1.875	47.62	.3125-24	1.000	25.40	.438	11.12	.500	12.70	—	—	—	—	.10	0.045
~ABRL5F-11	.3125	7.938	1.250	31.75	.870	22.10	.656	16.66	.501	12.73	3/16	1.875	47.62	.3125-24L	1.000	25.40	.438	11.12	.500	12.70	—	—	—	—	.10	0.045

Notes:

- Radial Clearance: .0004" (0.010mm) MAX. Axial Clearance: .003" (0.08mm) MAX.
- Surface Finish: Balls and Raceways - 8 microinches AA (0.2µmRa), Shank - 63 microinches AA (1.6µmRa).
- Lubrication: Prepacked with grease per MIL-PRF-81322. If grease per MIL-PRF-23827 is required, add suffix "G" to part number. EXAMPLE: ABR4M-8G.
- Plating: Exposed surfaces as mounted are Cadmium plated. Dimensions are met after Plating.
- All dimensions, materials and configurations conform to requirements of MS spec. Consult QPL AS6039 for NMB approvals to MS21153.

MATERIALS

Inner Race & Balls	Seal Retainer	Seal [~]	Body ^④
52100 STL. 60-66 HRC	300 Series CRES	Teflon*	8620 STL. 90KSI MIN Tensile Strength Raceway Carburized to 59-63 HRC MIN

~ Removeable

NMB Part Number	Radial Limit Load [†]		Axial Limit Load [†]		Dynamic Radial Load Rating Average Life of 10,000 Complete 90° Cycles [†]	
	lbs	N	lbs	N	lbs	N
ABR3F-1, -2, -3 ABRL3F-4, -5	1000	4448	200	890	1000	4448
ABR4F-6, -8 ABRL4F-7, -9	1720	7651	345	1535	1720	7651
ABR5F-10 ABRL5F-11	2920	12988	585	2602	2920	12988

* A trademark of E.I. duPont de Nemours & Co., Inc.

† LOAD RATINGS are for operation up to 250°F (121°C). For operation above 250°F (121°C), reduce ratings by 20%.

† RADIAL FRACTURE LOAD is 1.5 times radial limit load - AXIAL FRACTURE LOAD is 1.5 times axial limit load.



ABR-H, ABR-S

Ball Bearings Rod Ends, Double Row
MS21152, Hollow Shank, MS21150, Solid Shank

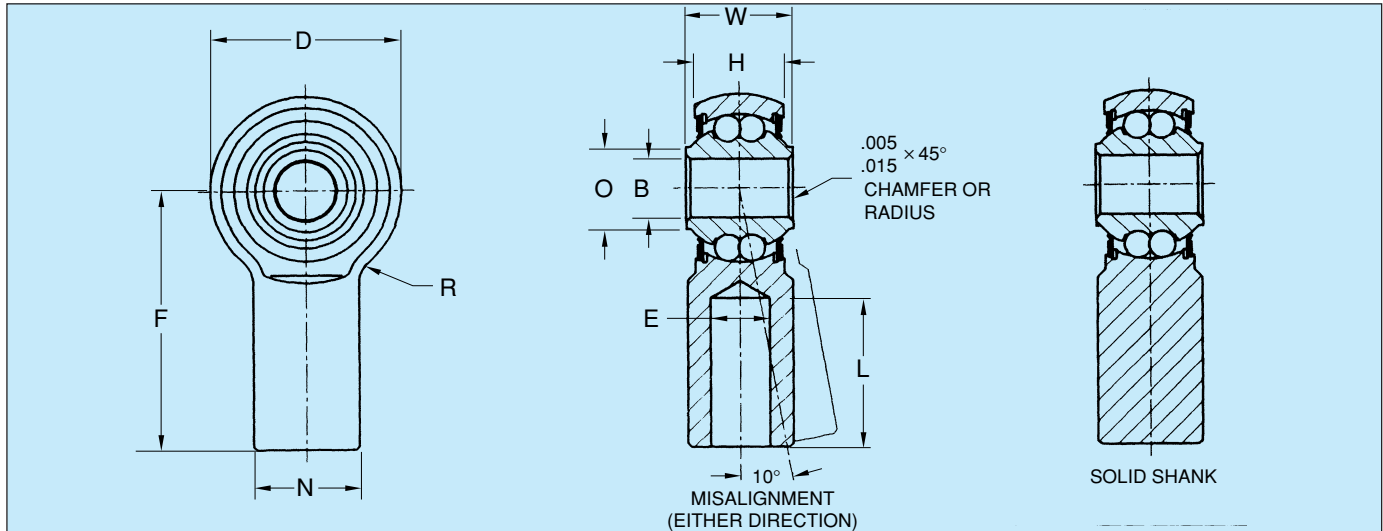

NMB Part Number	(B) Bore Diameter		(D) Head Diameter		(W) Inner Race Width		(H) Body Width		(O) Shoulder Diameter		(F) Length C/L to End		(E) Hole Diameter		(L) Hole Depth		(N) Shank Diameter		(R) Radius		Approx. Weight		
	Inch	mm	Inch	mm	Inch	mm	Inch	mm	Inch	mm	Inch	mm	Inch	mm	Inch	mm	Inch	mm	Inch	mm	lbs	kg	
	+0.000	+0.000	+0.010	+0.25	+0.000	+0.00	+0.010	+0.25			+0.010	+0.25	+0.010	+0.25	+0.031	+0.79	+0.000	+0.00	Ref.	Ref.			
	-0.003	-0.008	-0.010	-0.25	-0.005	-0.13	-0.010	-0.25	MIN	MIN	Size	-0.010	-0.25	-0.010	-0.25	-0.031	-0.79	-0.002	-0.05				
Hollow Shank																							
ABR3H-1	.1900	4.826	.781	19.84	.437	11.10	.328	8.33	.276	7.01	1/8	1.375	34.92	.272	6.91	.875	22.22	.430	10.92	.390	9.91	.06	0.027
ABR4H-2	.2500	6.350	.938	23.83	.593	15.06	.438	11.12	.340	8.64	5/32	1.875	47.62	.386	9.80	1.219	30.96	.625	15.88	.490	12.45	.12	0.054
ABR4H-3	.2500	6.350	.938	23.83	.593	15.06	.438	11.12	.340	8.64	5/32	1.625	41.28	.515	13.08	.875	22.22	.625	15.88	.500	12.70	.08	0.036
ABR4H-4	.2500	6.350	.938	23.83	.593	15.06	.438	11.12	.340	8.64	5/32	1.875	47.62	.346	8.79	.750	19.05	.438	11.12	.468	11.89	.12	0.054
ABR4H-5	.2500	6.350	.938	23.83	.593	15.06	.438	11.12	.340	8.64	5/32	1.875	47.62	.500	12.70	1.125	28.58	.625	15.88	.500	12.70	.09	0.041
Solid Shank																							
ABR3S-1	.1900	4.826	.781	19.84	.437	11.10	.328	8.33	.276	7.01	1/8	1.375	34.92	—	—	—	—	.430	10.92	.390	9.91	.07	0.032
ABR4S-2	.2500	6.350	.938	23.83	.593	15.06	.438	11.12	.340	8.64	5/32	1.875	47.62	—	—	—	—	.625	15.88	.500	12.70	.16	0.073

Notes:

- Radial Clearance: .0004 (0.010mm) MAX. Axial Clearance: .003" (0.08mm) MAX.
- Surface Finish: Balls and Raceways - 8 microinches AA (0.2µmRa), Shank - 63 microinches AA (1.6µmRa).
- Lubrication: Prepacked with grease per MIL-PRF-81322. If grease per MIL-PRF-23827 is required, add suffix "G" to part number. EXAMPLE: ABR4H-2G.
- Plating: Exposed surfaces as mounted are Cadmium plated. Dimensions are met after Plating.
- Diameters "E" and "N" are concentric within .010 (0.25mm) FIM.
- All dimensions, materials and configurations conform to requirements of MS spec. Consult QPL MIL-B-6039 for NMB approvals to MS21152 and MS21150.

MATERIALS

Inner Race & Balls	Seal Retainer	Seal~	Body ④
52100 STL. 60-66 HRC	300 Series CRES	Teflon*	8620 STL. 90KSI MIN Tensile Strength Raceway Carburized to 60 HRC MIN

~ Removeable

NMB Part Number	Radial Limit Load†		Axial Limit Load†		Dynamic Radial Load Rating Average Life of 10,000 Complete 90° Cycles¹	
	lbs	N	lbs	N	lbs	N
Hollow Shank						
ABR3H-1	1000	4448	200	890	1000	4448
ABR4H-2	1720	7651	345	1535	1720	7651
ABR4H-3	1720	7651	345	1535	1720	7651
ABR4H-4	1720	7651	345	1535	1720	7651
ABR4H-5	1720	7651	345	1535	1720	7651
Solid Shank						
ABR3S-1	1000	4448	200	890	1000	4448
ABR4S-2	1720	7651	345	1535	1720	7651

* A trademark of E.I. duPont de Nemours & Co., Inc.

† LOAD RATINGS are for operation up to 250°F (121°C). For operation above 250°F (121°C), reduce ratings by 20%.

‡ RADIAL FRACTURE LOAD is 1.5 times radial limit load - AXIAL FRACTURE LOAD is 1.5 times axial limit load.

MS to NMB Part Numbers Ball Bearings Rod Ends, Double Row MS21151 Male

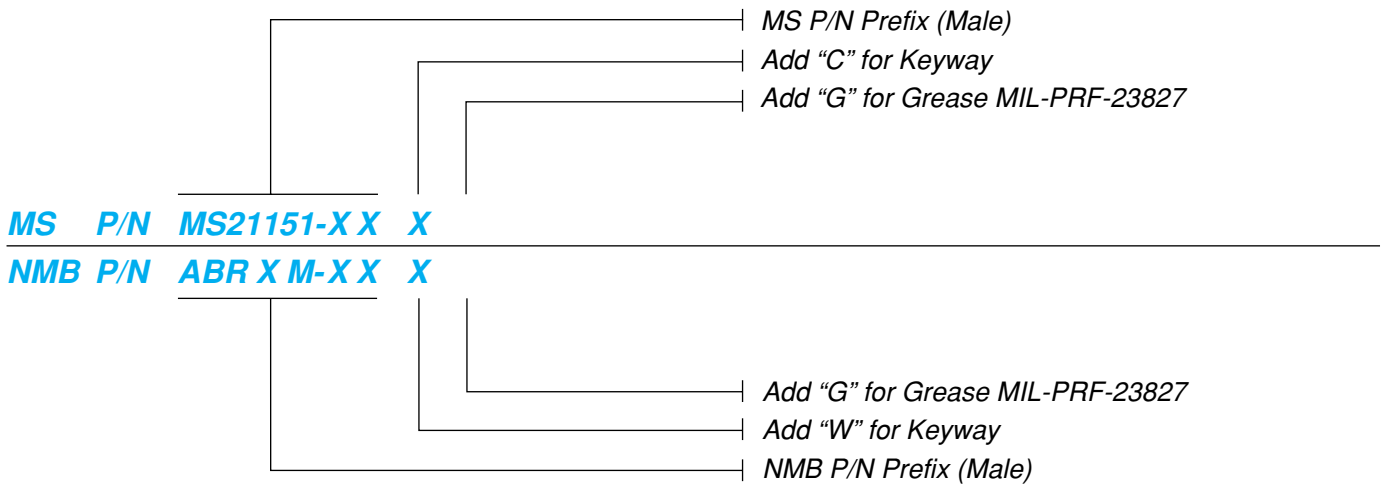

MS21151

MS	NMB
MS21151-1	ABRL3M-1
MS21151-2	ABR3M-2
MS21151-3	ABR3M-3
MS21151-4	ABR3M-4
MS21151-5	ABRL3M-5
MS21151-6	ABR3M-6
MS21151-7	ABR3M-7
MS21151-8	ABR4M-8
MS21151-9	ABRL4M-9
MS21151-10	ABR5M-10
MS21151-11	ABR5M-11
MS21151-12	ABR5M-12
MS21151-13	ABR10M-13

MS21151-C

MS	NMB
MS21151-1C	ABRL3M-1W
MS21151-2C	ABR3M-2W
MS21151-3C	ABR3M-3W
MS21151-4C	ABR3M-4W
MS21151-5C	ABRL3M-5W
MS21151-6C	ABR3M-6W
MS21151-7C	ABR3M-7W
MS21151-8C	ABR4M-8W
MS21151-9C	ABRL4M-9W
MS21151-10C	ABR5M-10W
MS21151-11C	ABR5M-11W
MS21151-12C	ABR5M-12W
MS21151-13C	ABR10M-13W

MS21151-G

MS	NMB
MS21151-1G	ABRL3M-1G
MS21151-2G	ABR3M-2G
MS21151-3G	ABR3M-3G
MS21151-4G	ABR3M-4G
MS21151-5G	ABRL3M-5G
MS21151-6G	ABR3M-6G
MS21151-7G	ABR3M-7G
MS21151-8G	ABR4M-8G
MS21151-9G	ABRL4M-9G
MS21151-10G	ABR5M-10G
MS21151-11G	ABR5M-11G
MS21151-12G	ABR5M-12G
MS21151-13G	ABR10M-13G

MS21151-CG

MS	NMB
MS21151-1CG	ABRL3M-1WG
MS21151-2CG	ABR3M-2WG
MS21151-3CG	ABR3M-3WG
MS21151-4CG	ABR3M-4WG
MS21151-5CG	ABRL3M-5WG
MS21151-6CG	ABR3M-6WG
MS21151-7CG	ABR3M-7WG
MS21151-8CG	ABR4M-8WG
MS21151-9CG	ABRL4M-9WG
MS21151-10CG	ABR5M-10WG
MS21151-11CG	ABR5M-11WG
MS21151-12CG	ABR5M-12WG
MS21151-13CG	ABR10M-13WG



MS to NMB Part Numbers

Ball Bearings Rod Ends, Double Row

MS21153

Female

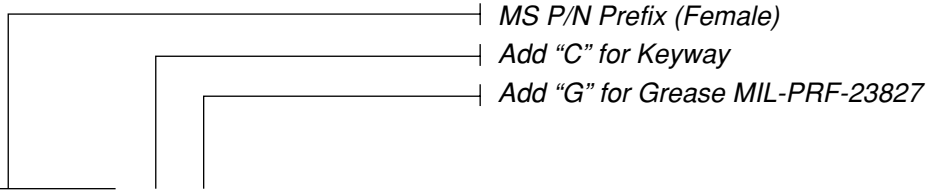

MS P/N MS21153-XX X

NMB P/N ABRXF - X X X

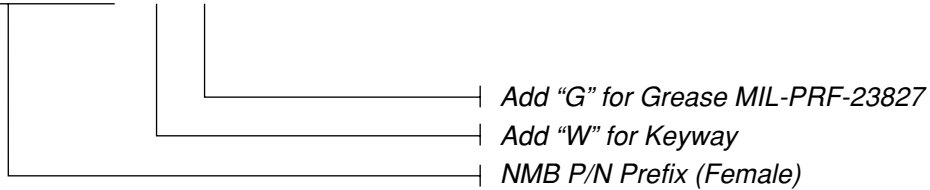

MS21153

MS	NMB
MS21153-1	ABR3F-1
MS21153-2	ABR3F-2
MS21153-3	ABR3F-3
MS21153-4	ABRL3F-4
MS21153-5	ABRL3F-5
MS21153-6	ABR4F-6
MS21153-7	ABRL4F-7
MS21153-8	ABR4F-8
MS21153-9	ABRL4F-9
MS21153-10	ABR5F-10
MS21153-11	ABRL5F-11

MS21153-C

MS	NMB
MS21153-1C	ABR3F-1W
MS21153-2C	ABR3F-2W
MS21153-3C	ABR3F-3W
MS21153-4C	ABRL3F-4W
MS21153-5C	ABRL3F-5W
MS21153-6C	ABR4F-6W
MS21153-7C	ABRL4F-7W
MS21153-8C	ABR4F-8W
MS21153-9C	ABRL4F-9W
MS21153-10C	ABR5F-10W
MS21153-11C	ABRL5F-11W

MS21153-G

MS	NMB
MS21153-1G	ABR3F-1G
MS21153-2G	ABR3F-2G
MS21153-3G	ABR3F-3G
MS21153-4G	ABRL3F-4G
MS21153-5G	ABRL3F-5G
MS21153-6G	ABR4F-6G
MS21153-7G	ABRL4F-7G
MS21153-8G	ABR4F-8G
MS21153-9G	ABRL4F-9G
MS21153-10G	ABR5F-10G
MS21153-11G	ABRL5F-11G

MS21153-CG

MS	NMB
MS21153-1CG	ABR3F-1WG
MS21153-2CG	ABR3F-2WG
MS21153-3CG	ABR3F-3WG
MS21153-4CG	ABRL3F-4WG
MS21153-5CG	ABRL3F-5WG
MS21153-6CG	ABR4F-6WG
MS21153-7CG	ABRL4F-7WG
MS21153-8CG	ABR4F-8WG
MS21153-9CG	ABRL4F-9WG
MS21153-10CG	ABR5F-10WG
MS21153-11CG	ABRL5F-11WG

MS to NMB Part Numbers

Ball Bearings Rod Ends, Double Row MS21152 Hollow Shank & MS21150 Solid Shank

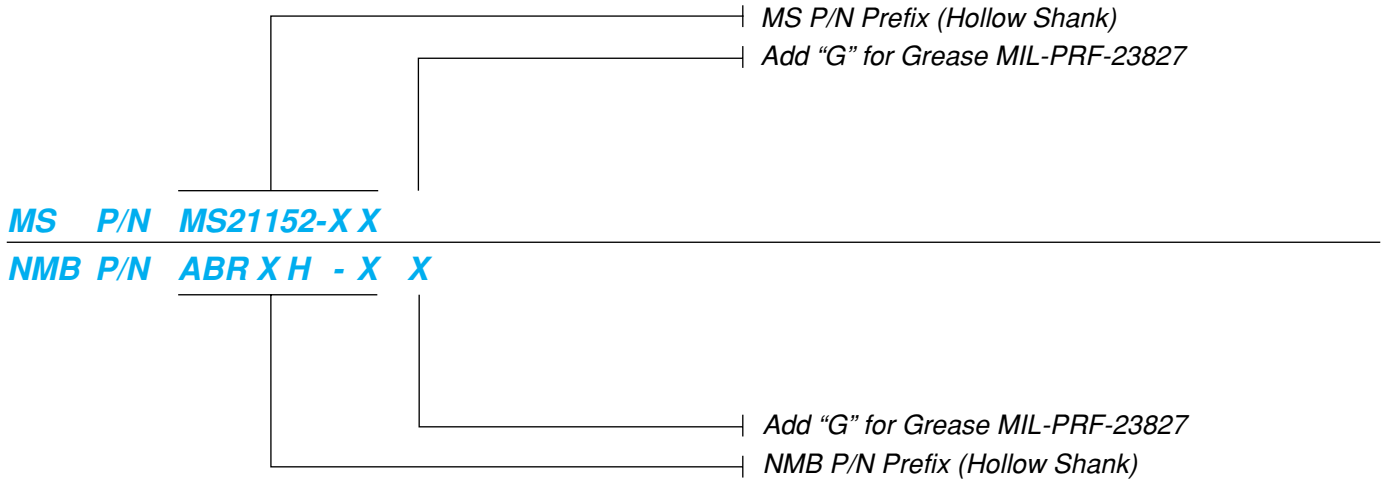

MS21152

MS	NMB
MS21152-1	ABR3H-1
MS21152-2	ABR4H-2
MS21152-3	ABR4H-3
MS21152-4	ABR4H-4
MS21155-5	ABR4H-5

MS21152-G

MS	NMB
MS21152-1G	ABR3H-1G
MS21152-2G	ABR4H-2G
MS21152-3G	ABR4H-3G
MS21152-4G	ABR4H-4G
MS21155-5G	ABR4H-5G

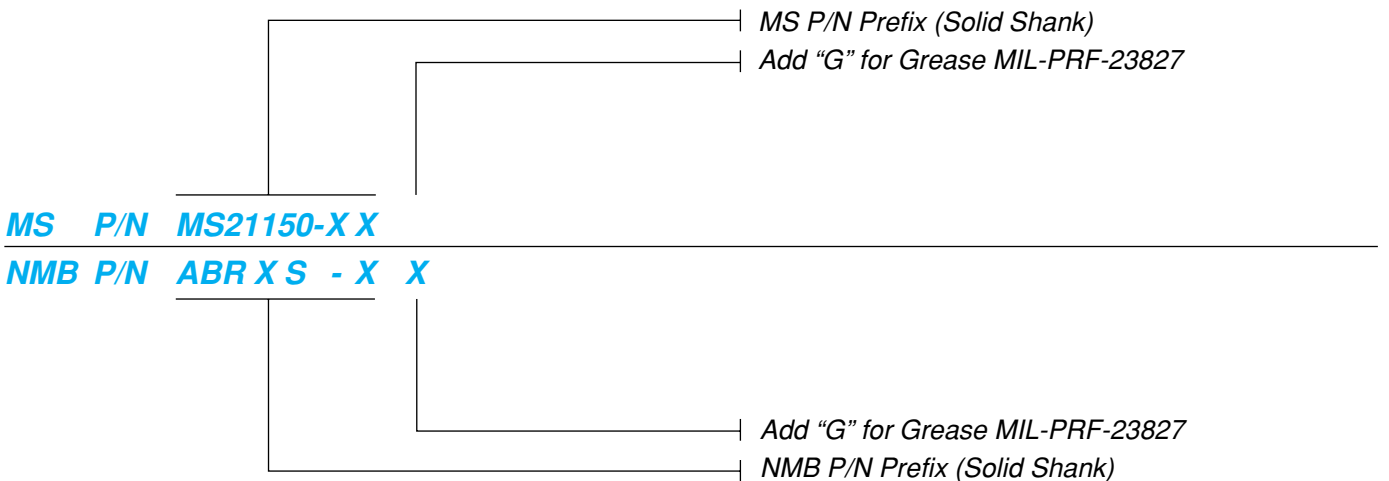

MS21150

MS	NMB
MS21150-1	ABR3S-1
MS21150-2	ABR4S-2

MS21150-G

MS	NMB
MS21150-1G	ABR3S-1G
MS21150-2G	ABR4S-2G



AJ-A, AJ-C

Journal, Plain - Teflon Lined
 **MS21240

Temperature: Operating temperature range -65° to 250°F.
 (-54° to 121°C)

Concentricity tolerance between B and D diameters shall not exceed .003" (0.08mm) FIM

MATERIALS

Material Code	Journal	Liner
AJ-A	Aluminum Alloy AMS-QQ-A-225/9 or AMS-QQ-A-200/11. Finish Anodized per MIL-A-8625,	*Teflon/Fabric Bonded to bore no lub. required.
AJ-C	CRES 410 H.T. to 27-32 HRC	*Teflon/Fabric Bonded to bore no lub. required.

NMB Part Number	(B) Bore Diameter		(D) Outside Diameter				Weight Lbs./In. (Ref.) L = 1,000 (25.4mm)			
	Inch	mm	ALUM.		CRES		ALUM.		CRES	
			Inch	mm	Inch	mm	lb/in	g/mm	lb/in	g/mm
MS21240	+0.0000	+0.000	+0.0005	+0.013	+0.0000	+0.000				
Plain	-.0010	-0.025	-.0005	-0.013	-.0005	-0.013				
AJ04	.2515	6.388	.3760	9.550	.3760	9.550	.006	0.11	.017	0.30
AJ05	.3140	7.976	.4386	11.140	.4386	11.140	.008	0.14	.022	0.39
AJ06	.3765	9.563	.5012	12.730	.5012	12.730	.009	0.16	.025	0.45
AJ07	.4390	11.151	.5638	14.321	.5638	14.321	.010	0.18	.028	0.50
AJ08	.5015	12.738	.6265	15.913	.6265	15.913	.011	0.20	.031	0.55
AJ09	.5640	12.326	.6892	17.506	.6892	17.506	.013	0.23	.036	0.64
AJ10	.6265	15.913	.8142	20.681	.8142	20.681	.022	0.39	.061	1.09
AJ11	.6890	17.501	.8767	22.268	.8767	22.268	.023	0.41	.064	1.14
AJ12	.7515	19.088	.9393	23.858	.9393	23.858	.025	0.45	.070	1.25
AJ14	.8765	22.263	1.0645	27.038	1.0645	27.038	.029	0.52	.080	1.43
AJ16	1.0015	25.438	1.1898	30.221	1.1898	30.221	.033	0.59	.091	1.63
AJ18	1.1265	28.613	1.3148	33.396	1.3148	33.396	.037	0.66	.101	1.80
AJ20	1.2515	31.788	1.4398	36.571	1.4398	36.571	.040	0.71	.111	1.98
AJ22	1.3765	34.963	1.5648	39.746	1.5648	39.746	.044	0.79	.122	2.18
AJ24	1.5015	38.138	1.7523	44.508	1.7523	44.508	.065	1.16	.179	3.20
AJ26	1.6265	41.313	1.8773	47.638	1.8773	47.638	.070	1.25	.193	3.45
AJ28	1.7515	44.488	2.0023	50.858	2.0023	50.858	.075	1.34	.207	3.70
AJ32	2.0015	50.838	2.2523	57.208	2.2523	57.208	.085	1.52	.234	4.18

Shaft and Housing Information

For optimum performance with lined journal bearings, considerable care must be exercised in the design of housings and shafts. For extreme applications involving dissimilar materials, elevated temperatures, or extreme loads, contact NMB Engineering for application recommendations. The adjacent table applies to normal conditions.

	Shaft	Housing
Diameter	B -.0010" (0.025mm) to -.0020" (0.051mm)	D -.0006" (0.015mm) to -.0011" (0.028mm)
Taper and Roundness	Not to exceed .0005" (0.013mm)	Not to exceed .0005" (0.013mm)
Finish	8 RHR (0.2µmRa) Polished or honed after grind	
Hardness	50 HRC MIN	

* A trademark of E.I. duPont de Nemours & Co., Inc.
 ** MIL-B-8943 (MS21240) was superseded to AS81934/1

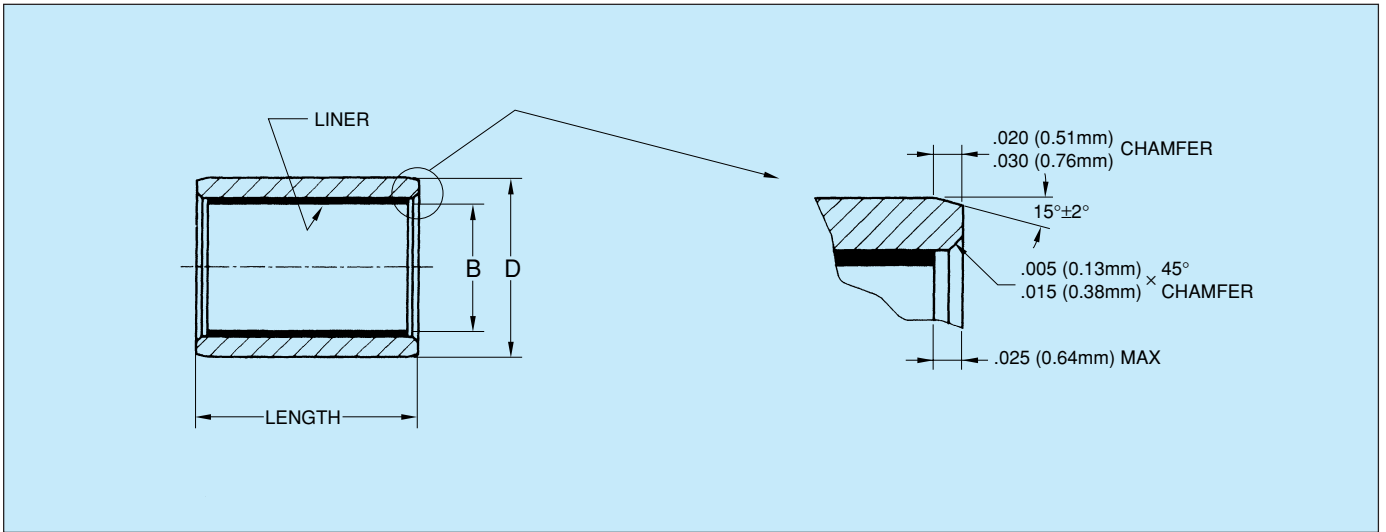

**LENGTH (Tolerance + .000,-.010)
(+0.00, -0.25mm)**

mm	6.35	7.14	7.94	8.73	9.52	11.11	12.70	14.29	15.88	17.46	19.05	22.22	25.40	28.58	31.75	34.92	38.10	41.28	44.45	47.62	50.80	53.98	57.15	60.32	63.50	69.85	76.20
Bore Code	1/4	9/32	5/16	11/32	3/8	7/16	1/2	9/16	5/8	11/16	3/4	7/8	1	1 1/8	1 1/4	1 3/8	1 1/2	1 5/8	1 3/4	1 7/8	2	2 1/8	2 1/4	2 3/8	2 1/2	2 3/4	3

04	08	09	10	11	12	14																						
05	08	09	10	11	12	14	16	18																				
06	08	09	10	11	12	14	16	18	20	22																		
07	08	09	10	11	12	14	16	18	20	22	24	28																
08	08	09	10	11	12	14	16	18	20	22	24	28																
09	08	09	10	11	12	14	16	18	20	22	24	28	32	36														
10	08	09	10	11	12	14	16	18	20	22	24	28	32	36	40	44												
11	08	09	10	11	12	14	16	18	20	22	24	28	32	36	40	44	48	52										
12	08	09	10	11	12	14	16	18	20	22	24	28	32	36	40	44	48	52										
14	08	09	10	11	12	14	16	18	20	22	24	28	32	36	40	44	48	52										
16	08	09	10	11	12	14	16	18	20	22	24	28	32	36	40	44	48	52	56	60								
18			10	11	12	14	16	18	20	22	24	28	32	36	40	44	48	52	56	60								
20					12	14	16	18	20	22	24	28	32	36	40	44	48	52	56	60	64	68						
22					12	14	16	18	20	22	24	28	32	36	40	44	48	52	56	60	64	68						
24					12	14	16	18	20	22	24	28	32	36	40	44	48	52	56	60	64	68	72	76	80	88		
26							16	18	20	22	24	28	32	36	40	44	48	52	56	60	64	68	72	76	80	88		
28							16	18	20	22	24	28	32	36	40	44	48	52	56	60	64	68	72	76	80	88	96	
32							16	18	20	22	24	28	32	36	40	44	48	52	56	60	64	68	72	76	80	88	96	

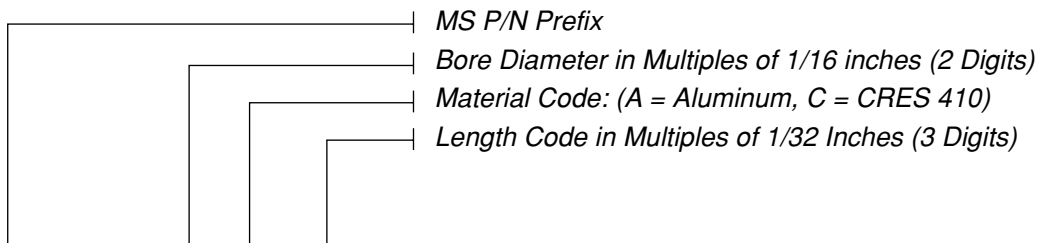

****MS P/N MS21240 - XX X XXX**

NMB P/N AJ XX X XX

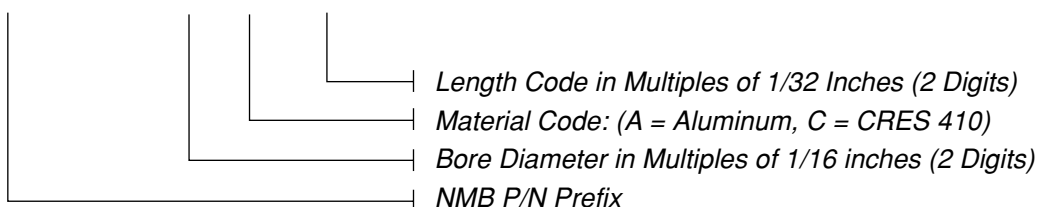



AJF-A, AJF-C

Journal, Flanged - Teflon Lined
**MS21241

Temperature: Operating temperature range -65° to 250°F.
(-54° to 121°C)
Concentricity tolerance between B and D diameters shall not exceed .003" (0.08mm) FIM

MATERIALS

Material Code	Journal	Liner
AJF-A	Aluminum Alloy AMS-QQ-A-225/9 or AMS-QQ-A-200/11. Finish Anodized per MIL-A-8625,	*Teflon/Fabric Bonded to bore and flange face. No lub. required.
AJF-C	CRES 410 H.T. to 27-32 HRC	*Teflon/Fabric Bonded to bore and flange face. No lub. required.

NMB Part Number	(B) Bore Diameter		(D) Outside Diameter				(H) Flange Diameter		(F) Flange Thickness		Sleeve Weight Lbs./In. (Ref.) L = 1.000 (25.4mm)				Flange Weight Lbs. (Ref.)			
	Inch	mm	ALUM.		CRES		Inch	mm	Inch	mm	ALUM.		CRES		ALUM.		CRES	
MS21241	+0.0000	+0.0000	+0.0005	+0.013	+0.0000	+0.0000	+0.000	+0.000	+0.000	+0.000								
Flanged	-.0010	-0.025	-.0005	-0.013	-.0005	-0.013	-.020	-0.508	-.005	-0.127								
AJF04	.2515	6.388	.3760	9.550	.3760	9.550	.750	19.050	.0625	1.588	.009	0.16	.024	0.43	.003	0.05	.007	0.12
AJF05	.3140	7.976	.4386	11.140	.4386	11.140	.812	20.625	.0625	1.588	.011	0.20	.028	0.50	.003	0.05	.007	0.12
AJF06	.3765	9.563	.5012	12.730	.5012	12.730	.875	22.225	.0625	1.588	.012	0.21	.032	0.57	.003	0.05	.007	0.12
AJF07	.4390	11.151	.5638	14.321	.5638	14.321	.937	23.800	.0625	1.588	.013	0.23	.036	0.64	.003	0.05	.008	0.14
AJF08	.5015	12.738	.6265	15.913	.6265	15.913	1.000	25.400	.0625	1.588	.015	0.27	.041	0.73	.004	0.07	.010	0.18
AJF09	.5640	12.326	.6892	17.506	.6892	17.506	1.125	28.575	.0625	1.588	.017	0.30	.047	0.84	.004	0.07	.011	0.20
AJF10	.6265	15.913	.8142	20.681	.8142	20.681	1.250	31.750	.0625	1.588	.027	0.48	.075	1.34	.005	0.09	.011	0.25
AJF11	.6890	17.501	.8767	22.268	.8767	22.268	1.375	34.925	.0625	1.588	.030	0.54	.084	1.50	.007	0.12	.020	0.36
AJF12	.7515	19.088	.9393	23.858	.9393	23.858	1.500	38.100	.0625	1.588	.034	0.61	.093	1.66	.009	0.16	.023	0.41
AJF14	.8765	22.263	1.0645	27.038	1.0645	27.038	1.625	41.275	.0625	1.588	.038	0.68	.104	1.86	.009	0.16	.025	0.45
AJF16	1.0015	25.438	1.1898	30.221	1.1898	30.221	1.750	44.450	.0625	1.588	.043	0.77	.118	2.11	.010	0.18	.027	0.48
AJF18	1.1265	28.613	1.3148	33.396	1.3148	33.396	1.875	47.625	.0937	2.380	.051	0.91	.142	2.54	.014	0.25	.041	0.73
AJF20	1.2515	31.788	1.4398	36.571	1.4398	36.571	2.000	50.800	.0937	2.380	.058	1.04	.161	2.88	.018	0.32	.050	0.89
AJF22	1.3765	34.963	1.5648	39.746	1.5648	39.746	2.125	53.975	.0937	2.380	.063	1.13	.175	3.13	.019	0.34	.053	0.95
AJF24	1.5015	38.138	1.7523	44.508	1.7523	44.508	2.250	57.150	.0937	2.380	.081	1.45	.233	4.16	.019	0.34	.054	0.96
AJF26	1.6265	41.313	1.8773	47.638	1.8773	47.638	2.375	60.325	.0937	2.380	.090	1.61	.249	4.45	.020	0.36	.056	1.00
AJF28	1.7515	44.488	2.0023	50.858	2.0023	50.858	2.500	63.500	.0937	2.380	.099	1.77	.272	4.86	.023	0.41	.064	1.14
AJF32	2.0015	50.838	2.2523	57.208	2.2523	57.208	2.750	69.850	.0937	2.380	.111	1.98	.306	5.46	.026	0.46	.072	1.29

Shaft and Housing Information

For optimum performance with lined journal bearings, considerable care must be exercised in the design of housings and shafts. For extreme applications involving dissimilar materials, elevated temperatures, or extreme loads, contact NMB Engineering for application recommendations. The adjacent table applies to normal conditions.

	Shaft	Housing
Diameter	B -.0010" (0.025mm) to -.0020" (0.051mm)	D -.0006" (0.015mm) to -.0011" (0.028mm)
Taper and Roundness	Not to exceed .0005" (0.013mm)	Not to exceed .0005" (0.013mm)
Finish	8 RHR(0.2µmRa) Polished or honed after grind	
Hardness	50 HRC MIN	

* A trademark of E.I. duPont de Nemours & Co., Inc.
** MIL-B-8943 (MS21241) was superseded to AS81934/2

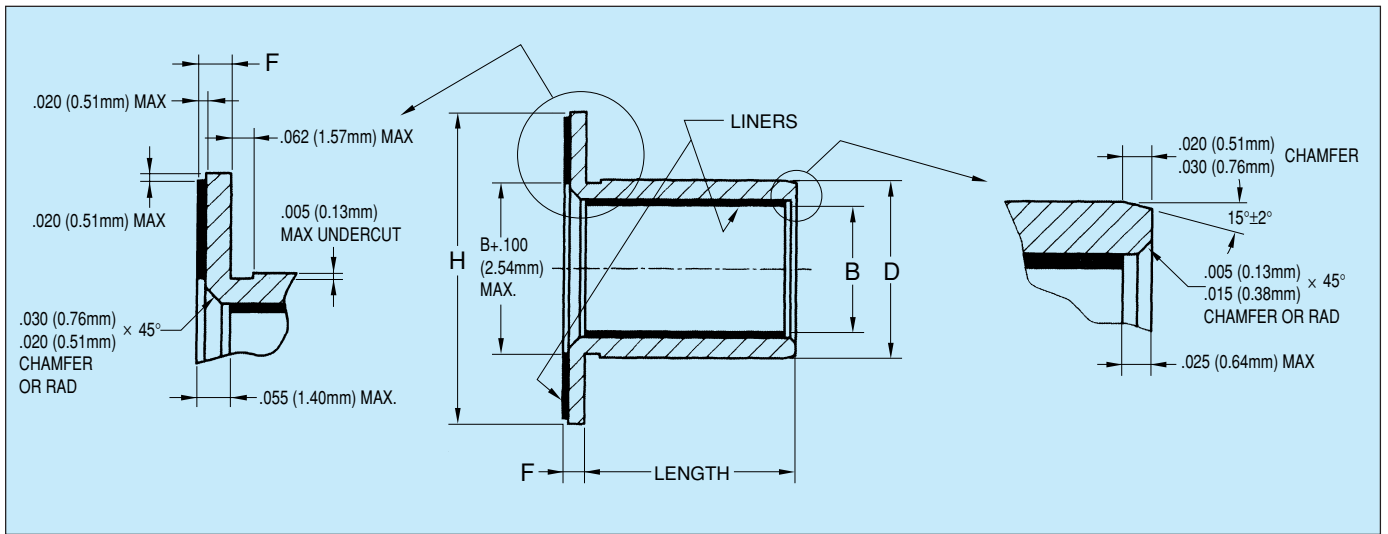

**LENGTH (Tolerance + .000,-.010)
(+0.00, -0.25mm)**

mm	6.35	7.14	7.94	8.73	9.52	11.11	12.70	14.29	15.88	17.46	19.05	22.22	25.40	28.58	31.75	34.92	38.10	41.28	44.45	47.62	50.80	53.98	57.14	60.32	63.05	69.85	76.20
Bore Code	1/4	3/32	5/16	11/32	3/8	7/16	1/2	9/16	5/8	11/16	3/4	7/8	1	1 1/8	1 1/4	1 3/8	1 1/2	1 5/8	1 3/4	1 7/8	2	2 1/8	2 1/4	2 3/8	2 1/2	2 3/4	3

04	08	09	10	11	12	14																						
05	08	09	10	11	12	14	16	18																				
06	08	09	10	11	12	14	16	18	20	22																		
07	08	09	10	11	12	14	16	18	20	22	24	28																
08	08	09	10	11	12	14	16	18	20	22	24	28																
09	08	09	10	11	12	14	16	18	20	22	24	28	32	36														
10	08	09	10	11	12	14	16	18	20	22	24	28	32	36	40	44												
11	08	09	10	11	12	14	16	18	20	22	24	28	32	36	40	44	48	52										
12	08	09	10	11	12	14	16	18	20	22	24	28	32	36	40	44	48	52										
14	08	09	10	11	12	14	16	18	20	22	24	28	32	36	40	44	48	52										
16	08	09	10	11	12	14	16	18	20	22	24	28	32	36	40	44	48	52	56	60								
18			10	11	12	14	16	18	20	22	24	28	32	36	40	44	48	52	56	60								
20					12	14	16	18	20	22	24	28	32	36	40	44	48	52	56	60	64	68						
22					12	14	16	18	20	22	24	28	32	36	40	44	48	52	56	60	64	68						
24					12	14	16	18	20	22	24	28	32	36	40	44	48	52	56	60	64	68	72	76	80	88		
26							16	18	20	22	24	28	32	36	40	44	48	52	56	60	64	68	72	76	80	88	96	
28							16	18	20	22	24	28	32	36	40	44	48	52	56	60	64	68	72	76	80	88	96	
32							16	18	20	22	24	28	32	36	40	44	48	52	56	60	64	68	72	76	80	88	96	

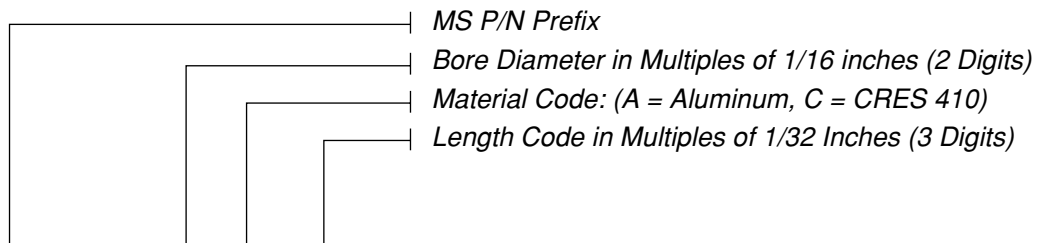

****MS P/N MS21241 - XX X XXX**

NMB P/N AJ XX X XX

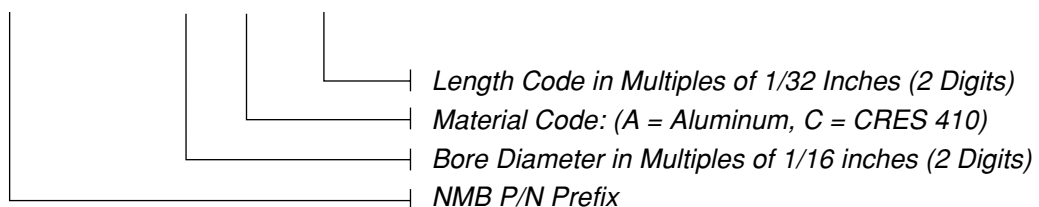



AHJ-A, AHJ-C

Journal, Plain - Teflon Lined
AS81934/1

Static limit load: Alum., 50000 psi × B(L - .10) = lbs.
 Alum., 344N/mm² × B(L - 2.54) = N (N);
 CRES, 78500 psi × B(L - .10) = lbs.
 CRES, 541 N/mm² × B(L - 2.54) = N (N)

Dynamic Capacity: 37500 × B (L - .10) = lbs.
 Temperature: Operating temperature range -65° to 325°F.
 (-54° to 163°)

Concentricity tolerance between B and D diameters shall not exceed .003" (0.08mm) FIM
 Bearings listed in table are approved for procurement to AS81934 and M81934/1.

MATERIALS

Materials Code	Journal	Liner
AHJ-A	Aluminum Alloy 2024 T851 or 2024-T8511 per AMS-QQ-A-225/6 or AMS-QQ-A 200/3. Finish Anodized per MIL-A-8625, Type I or II or Alodined per MIL-C-5541	*Teflon/Fabric Bonded to bore no lub. required.
AHJ-C	CRES 17-4PH/AMS 5643 H.T. to Condition H-1150 Passivated	*Teflon/Fabric Bonded to bore no lub. required.

NMB Part Number	(B) Bore Diameter		(D) Outside Diameter				Weight Lbs./In. (Ref.) L = 1,000 (25.4mm)			
	Inch	mm	ALUM.		CRES		ALUM.		CRES	
			Inch	mm	Inch	mm	lb/in	g/mm	lb/in	g/mm
M81934/1	+.0000	+0.000	+.0005	+0.013	+.0000	+0.000				
Plain	-.0010	-0.025	-.0005	-0.013	-.0005	-0.013				
AHJ04	.2515	6.388	.3760	9.550	.3760	9.550	.006	0.11	.016	0.29
AHJ05	.3140	7.976	.4386	11.140	.4386	11.140	.007	0.12	.019	0.34
AHJ06	.3765	9.563	.5012	12.730	.5012	12.730	.008	0.14	.022	0.39
AHJ07	.4390	11.151	.5638	14.321	.5638	14.321	.009	0.16	.025	0.45
AHJ08	.5015	12.738	.6265	15.913	.6265	15.913	.011	0.20	.028	0.50
AHJ09	.5640	14.326	.6892	17.506	.6892	17.506	.012	0.21	.031	0.55
AHJ10	.6265	15.913	.8142	20.681	.8142	20.681	.021	0.38	.056	1.00
AHJ11	.6890	17.501	.8767	22.268	.8767	22.268	.022	0.39	.060	1.07
AHJ12	.7515	19.088	.9393	23.858	.9393	23.858	.024	0.43	.065	1.16
AHJ14	.8765	22.263	1.0645	27.038	1.0645	27.038	.028	0.50	.075	1.34
AHJ16	1.0015	25.438	1.1898	30.221	1.1898	30.221	.031	0.55	.084	1.50
AHJ18	1.1265	28.613	1.3148	33.396	1.3148	33.396	.035	0.62	.094	1.68
AHJ20	1.2515	31.788	1.4398	36.571	1.4398	36.571	.038	0.68	.103	1.84
AHJ22	1.3765	34.963	1.5648	39.746	1.5648	39.746	.041	0.73	.113	2.02
AHJ24	1.5015	38.138	1.7523	44.508	1.7523	44.508	.062	1.11	.171	3.05
AHJ26	1.6265	41.313	1.8773	47.638	1.8773	47.638	.067	1.20	.183	3.27
AHJ28	1.7515	44.488	2.0023	50.858	2.0023	50.858	.071	1.27	.196	3.50
AHJ32	2.0015	50.838	2.2523	57.208	2.2523	57.208	.081	1.45	.222	3.96

Shaft and Housing Information

For optimum performance with lined journal bearings, considerable care must be exercised in the design of housings and shafts. For extreme applications involving dissimilar materials, elevated temperatures, or extreme loads, contact NMB Engineering for application recommendations. The adjacent table applies to normal conditions.

	Shaft	Housing
Diameter	B -.0010" (0.025mm) to -.0020" (0.051mm)	D -.0006" (0.015mm) to -.0011" (0.028mm)
Taper and Roundness	Not to exceed .0005" (0.013mm)	Not to exceed .0005" (0.013mm)
Finish	8 RHR (0.2µmRa) Polished or honed after grind	
Hardness	50 HRC MIN	

* A trademark of E.I., duPont de Nemours & Co., Inc.

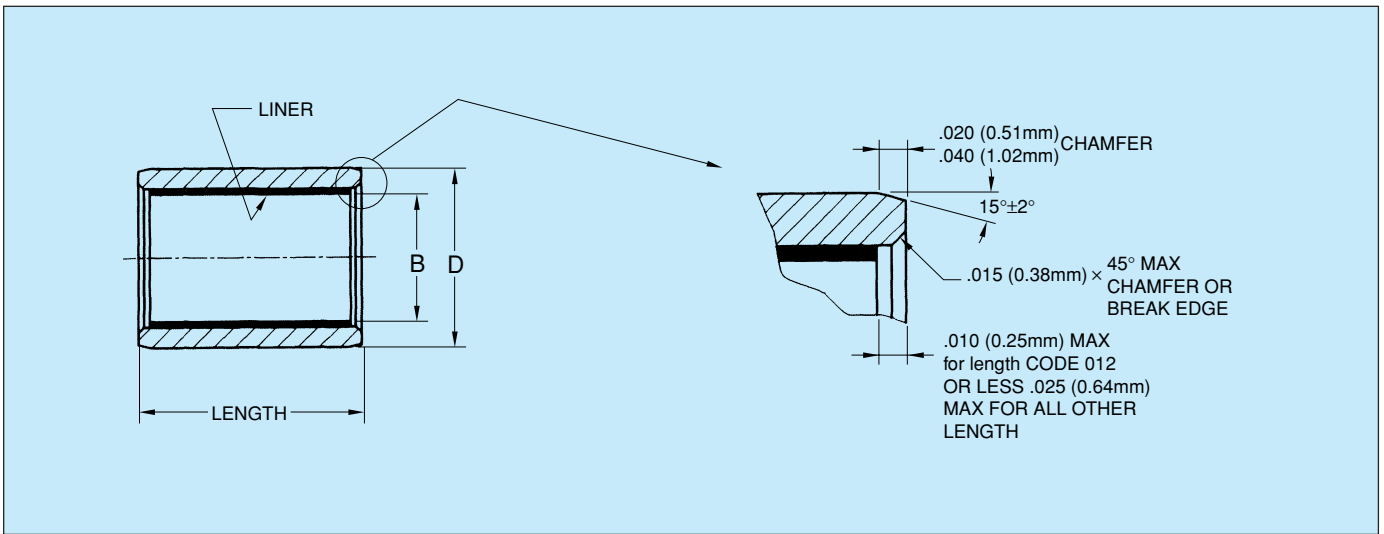

**LENGTH (Tolerance + .000,-.010)
(+0.00, -0.25mm)**

mm	3.96	4.75	5.54	6.35	7.14	7.92	8.71	9.52	11.10	12.70	14.27	15.88	17.45	19.05	22.22	25.40	28.58	31.75	34.92	38.10	41.28	44.45	47.62	50.80	53.98	57.14	60.32	63.50	69.85	76.20
Bore Code	.156	.187	.218	.250	.281	.312	.343	.375	.437	.500	.562	.625	.687	.750	.875	1.000	1.125	1.250	1.375	1.500	1.625	1.750	1.875	2.000	2.125	2.250	2.395	2.500	2.750	3.000

04	005	006	007	008	009	010	011	012	014																												
05	005	006	007	008	009	010	011	012	014	016	018																										
06	005	006	007	008	009	010	011	012	014	016	018	020	022																								
07	005	006	007	008	009	010	011	012	014	016	018	020	022	024	028																						
08	005	006	007	008	009	010	011	012	014	016	018	020	022	024	028																						
09	005	006	007	008	009	010	011	012	014	016	018	020	022	024	028	032	036																				
10	005	006	007	008	009	010	011	012	014	016	018	020	022	024	028	032	036	040	044																		
11				008	009	010	011	012	014	016	018	020	022	024	028	032	036	040	044	048	052																
12				008	009	010	011	012	014	016	018	020	022	024	028	032	036	040	044	048	052																
14				008	009	010	011	012	014	016	018	020	022	024	028	032	036	040	044	048	052																
16				008	009	010	011	012	014	016	018	020	022	024	028	032	036	040	044	048	052	056	060														
18					010	011	012	014	016	018	020	022	024	028	032	036	040	044	048	052	056	060															
20								012	014	016	018	020	022	024	028	032	036	040	044	048	052	056	060	064	068												
22								012	014	016	018	020	022	024	028	032	036	040	044	048	052	056	060	064	068												
24								012	014	016	018	020	022	024	028	032	036	040	044	048	052	056	060	064	068	072	076	080	088								
26									016	018	020	022	024	028	032	036	040	044	048	052	056	060	064	068	072	076	080	088	096								
28									016	018	020	022	024	028	032	036	040	044	048	052	056	060	064	068	072	076	080	088	096								
32									016	018	020	022	024	028	032	036	040	044	048	052	056	060	064	068	072	076	080	088	096								



AHJF-A, AHJF-C

Journal, Flanged - Teflon Lined
AS81934/2

Static limit load: Alum., 50000 psi × B(L + F - .13) = lbs.
 Alum., 344N/mm² × B(L + F - 3.30) = N (N);
 CRES, 78500 psi × B(L + F - .13) = lbs.
 CRES, 541 N/mm² × B(L + F - 3.30) = N (N)

Dynamic Capacity: 37500 × B(L + F - .13) = lbs.
 Temperature: Operating temperature range -65° to 325°F.
 (-54° to 163°)

Concentricity tolerance between B and D diameters shall not exceed .003 (0.08mm) FIM
 Bearings listed in table are approved for procurement to AS81934 and M81934/2.

MATERIALS

Materials Code	Journal	Liner
AHJF-A	Aluminum Alloy 2024 T851 or 2024-T8511 per AMS-QQ-A-225/6 or AMS-QQ-A 200/3. Finish Anodized per MIL-A-8625, Type I or II or Alodined per MIL-C-5541	*Teflon/Fabric Bonded to bore and flange face. No lub. required.
AHJF-C	CRES 17-4PH/AMS 5643 H.T. to Condition H-1150 Passivated	*Teflon/Fabric Bonded to bore and flange face. No lub. required.

NMB Part Number	(B) Bore Diameter		(D) Outside Diameter				(H) Flange Diameter		(F) Flange Thickness		Sleeve Weight Lbs./In. (Ref.) L = 1.000 (25.4mm)				Flange Weight Lbs. (Ref.)			
	Inch	mm	ALUM.		CRES		Inch	mm	Inch	mm	ALUM.		CRES		ALUM.		CRES	
MIL-B-81934/2	+0.000	+0.000	+0.0005	+0.013	+0.0000	+0.0000	+0.000	+0.000	+0.000	+0.000								
Flanged	-.0010	-0.025	-.0005	-0.013	-.0005	-0.013	-.020	-0.508	-.005	-0.127								
AHJF04	.2515	6.388	.3760	9.550	.3760	9.550	.750	19.050	.0625	1.587	.006	0.11	.016	0.29	.002	0.04	.006	0.11
AHJF05	.3140	7.976	.4386	11.140	.4386	11.140	.812	20.625	.0625	1.588	.007	0.12	.019	0.34	.003	0.05	.007	0.12
AHJF06	.3765	9.563	.5012	12.730	.5012	12.730	.875	22.225	.0625	1.588	.008	0.14	.022	0.39	.003	0.05	.007	0.12
AHJF07	.4390	11.151	.5638	14.321	.5638	14.321	.937	22.800	.0625	1.588	.009	0.16	.025	0.45	.003	0.05	.008	0.14
AHJF08	.5015	12.738	.6265	15.913	.6265	15.913	1.000	25.400	.0625	1.588	.011	0.20	.028	0.50	.003	0.05	.009	0.16
AHJF09	.5640	14.326	.6892	17.506	.6892	17.506	1.125	28.575	.0625	1.588	.012	0.21	.031	0.55	.004	0.07	.011	0.20
AHJF10	.6265	15.913	.8142	20.681	.8142	20.681	1.250	31.750	.0625	1.588	.021	0.38	.056	1.00	.005	0.09	.014	0.25
AHJF11	.6890	17.501	.8767	22.268	.8767	22.268	1.375	34.925	.0625	1.588	.022	0.39	.060	1.07	.006	0.11	.016	0.29
AHJF12	.7515	19.088	.9393	23.858	.9393	23.858	1.500	38.100	.0625	1.588	.024	0.43	.065	1.16	.007	0.13	.020	0.36
AHJF14	.8765	22.263	1.0645	27.038	1.0645	27.038	1.625	41.275	.0625	1.588	.028	0.50	.075	1.34	.008	0.14	.022	0.39
AHJF16	1.0015	25.438	1.1898	30.221	1.1898	30.221	1.750	44.450	.0625	1.588	.031	0.55	.084	1.50	.009	0.16	.024	0.43
AHJF18	1.1265	28.613	1.3148	33.396	1.3148	33.396	1.875	47.625	.0937	2.380	.035	0.62	.094	1.68	.015	0.27	.041	0.73
AHJF20	1.2515	31.788	1.4398	36.571	1.4398	36.571	2.000	50.800	.0937	2.380	.038	0.68	.103	1.84	.016	0.29	.045	0.80
AHJF22	1.3765	34.963	1.5648	39.746	1.5648	39.746	2.125	53.975	.0937	2.380	.041	0.73	.113	2.02	.017	0.30	.048	0.86
AHJF24	1.5015	38.138	1.7523	44.508	1.7523	44.508	2.250	57.150	.0937	2.380	.062	1.11	.171	3.05	.018	0.32	.051	0.91
AHJF26	1.6265	41.313	1.8773	47.638	1.8773	47.638	2.375	60.325	.0937	2.380	.067	1.20	.183	3.27	.020	0.36	.055	0.98
AHJF28	1.7515	44.488	2.0023	50.858	2.0023	50.858	2.500	63.500	.0937	2.380	.071	1.27	.196	3.50	.021	0.38	.058	1.04
AHJF32	2.0015	50.838	2.2523	57.208	2.2523	57.208	2.750	69.850	.0937	2.380	.081	1.45	.222	3.96	.023	0.41	.065	1.16

Shaft and Housing Information

For optimum performance with lined journal bearings, considerable care must be exercised in the design of housings and shafts. For extreme applications involving dissimilar materials, elevated temperatures, or extreme loads, contact NMB Engineering for application recommendations. The adjacent table applies to normal conditions.

	Shaft	Housing
Diameter	B -.0010 (0.025mm) to -.0020 (0.051mm)	D -.0006 (0.015mm) to -.0011 (0.028mm)
Taper and Roundness	Not to exceed .0005 (0.013mm)	Not to exceed .0005 (0.013mm)
Finish	8 RHR MAX (0.2µmRa MAX) Polished or honed after grind	
Hardness	50 HRC MIN	

* A trademark of E.I. duPont de Nemours & Co., Inc.

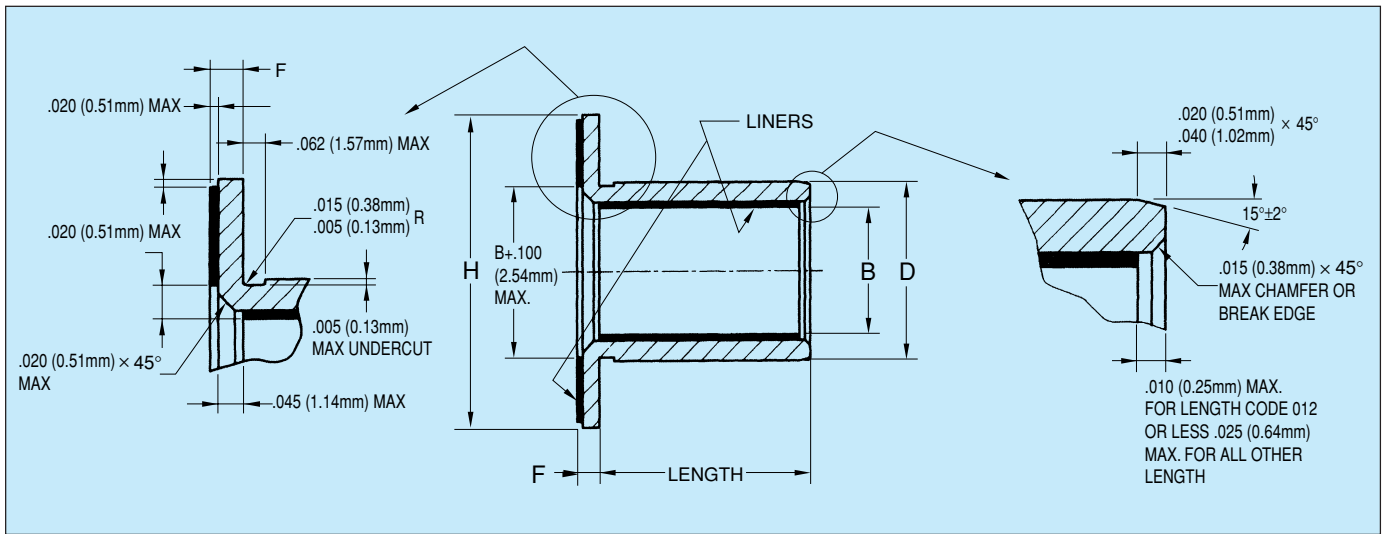

**LENGTH (Tolerance + .000,-.010)
(+0.00, -0.25mm)**

mm	3.96	4.75	5.54	6.35	7.14	7.92	8.71	9.52	11.10	12.70	14.27	15.88	17.45	19.05	22.22	25.40	28.58	31.75	34.92	38.10	41.28	44.45	47.62	50.80	53.98	57.14	60.32	63.50	69.85	76.20
Bore Code	.156	.187	.218	.250	.281	.312	.343	.375	.437	.500	.562	.625	.687	.750	.875	1.000	1.125	1.250	1.375	1.500	1.625	1.750	1.875	2.000	2.125	2.250	2.395	2.500	2.750	3.000

04	005	006	007	008	009	010	011	012	014																												
05	005	006	007	008	009	010	011	012	014	016	018																										
06	005	006	007	008	009	010	011	012	014	016	018	020	022																								
07	005	006	007	008	009	010	011	012	014	016	018	020	022	024	028																						
08	005	006	007	008	009	010	011	012	014	016	018	020	022	024	028																						
09	005	006	007	008	009	010	011	012	014	016	018	020	022	024	028	032	036																				
10	005	006	007	008	009	010	011	012	014	016	018	020	022	024	028	032	036	040	044																		
11				008	009	010	011	012	014	016	018	020	022	024	028	032	036	040	044	048	052																
12				008	009	010	011	012	014	016	018	020	022	024	028	032	036	040	044	048	052																
14				008	009	010	011	012	014	016	018	020	022	024	028	032	036	040	044	048	052																
16				008	009	010	011	012	014	016	018	020	022	024	028	032	036	040	044	048	052	056	060														
18					010	011	012	014	016	018	020	022	024	028	032	036	040	044	048	052	056	060															
20								012	014	016	018	020	022	024	028	032	036	040	044	048	052	056	060	064	068												
22								012	014	016	018	020	022	024	028	032	036	040	044	048	052	056	060	064	068												
24								012	014	016	018	020	022	024	028	032	036	040	044	048	052	056	060	064	068	072	076	080	088								
26									016	018	020	022	024	028	032	036	040	044	048	052	056	060	064	068	072	076	080	088	096								
28									016	018	020	022	024	028	032	036	040	044	048	052	056	060	064	068	072	076	080	088	096								
32									016	018	020	022	024	028	032	036	040	044	048	052	056	060	064	068	072	076	080	088	096								

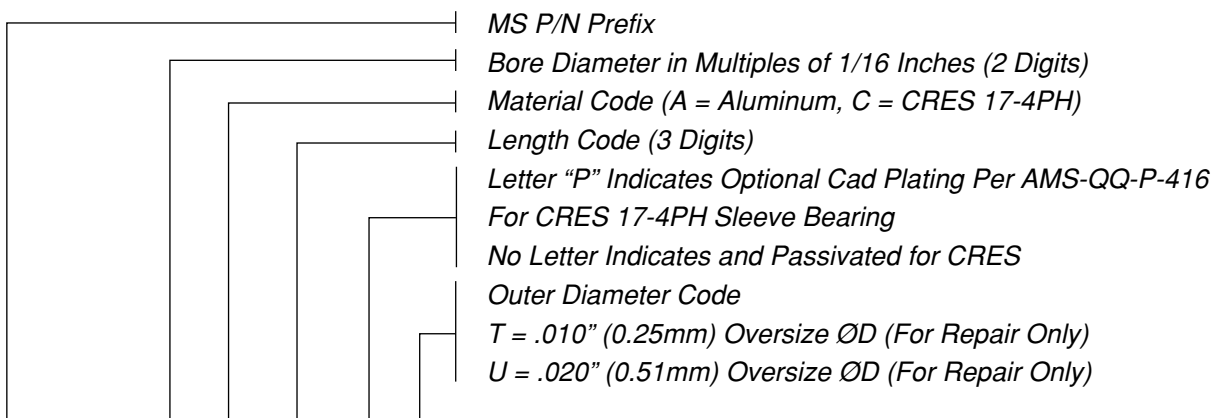

MS P/N M81934/1 - XX X XXX X X

NMB P/N AHJ XX X XXX X X

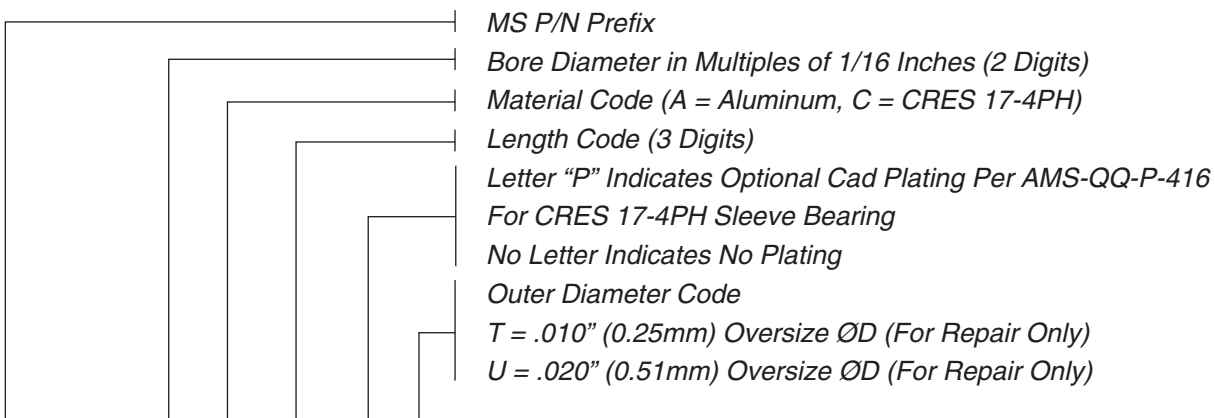
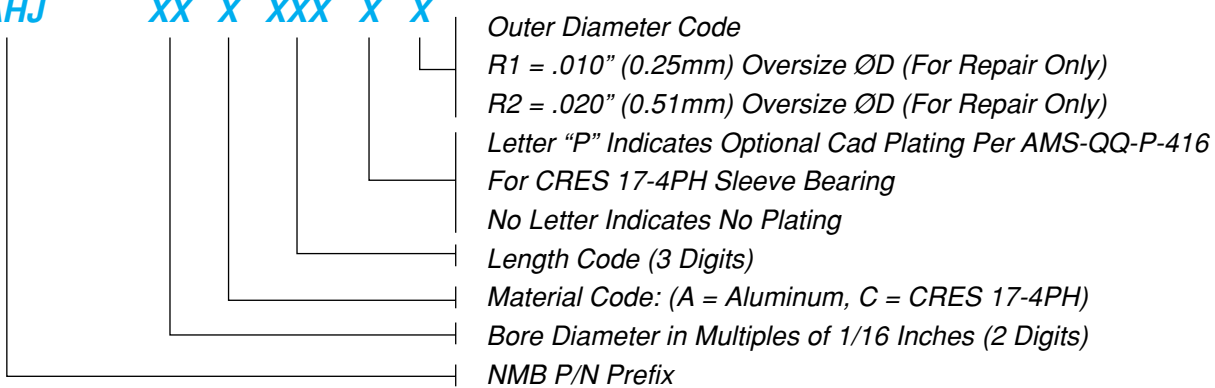

MS P/N M81934/2 - XX X XXX X X

NMB P/N AHJF XX X XXX X X

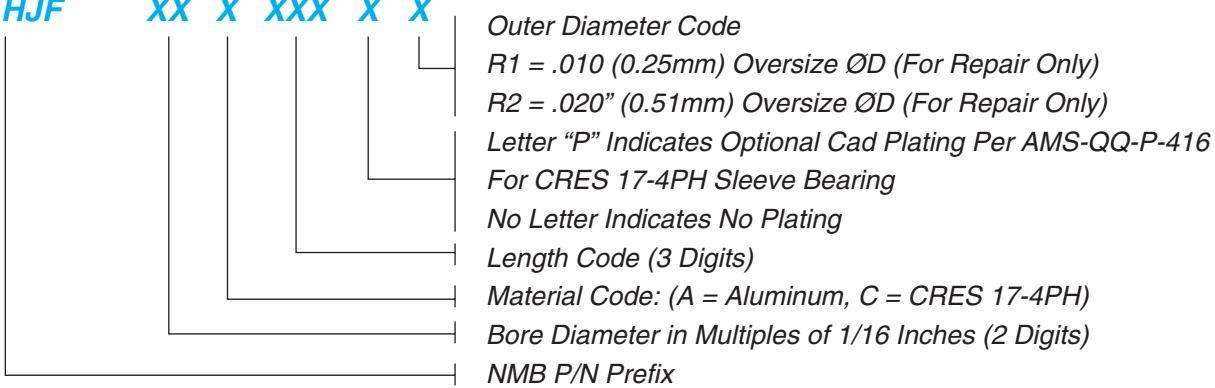

OVERSIZE BEARING DIMENSIONS (OUTSIDE DIMENSION)

M81934/1. M81934/2

DASH No	Nominal Bore Size	1st Oversize (.010) ØD	2nd Oversize (.020) ØD
-04	.2500 (6.350mm)	.3860 (9.804mm)	.3960 (10.058mm)
-05	.3125 (7.938mm)	.4486 (11.394mm)	.4586 (11.648mm)
-06	.3750 (9.525mm)	.5112 (12.984mm)	.5212 (13.238mm)
-07	.4375 (11.112mm)	.5738 (14.575mm)	.5838 (14.829mm)
-08	.5000 (12.700mm)	.6365 (16.167mm)	.6465 (16.421mm)
-09	.5625 (14.288mm)	.6992 (17.760mm)	.7092 (18.014mm)
-10	.6250 (15.875mm)	.8242 (20.935mm)	.8342 (21.189mm)
-11	.6875 (17.462mm)	.8867 (22.522mm)	.8967 (22.776mm)
-12	.7500 (19.050mm)	.9493 (24.112mm)	.9593 (24.366mm)
-14	.8750 (22.225mm)	1.0745 (27.292mm)	1.0845 (27.546mm)
-16	1.0000 (25.400mm)	1.1998 (30.475mm)	1.2098 (30.729mm)
-18	1.1250 (28.575mm)	1.3248 (33.650mm)	1.3348 (33.904mm)
-20	1.2500 (31.750mm)	1.4498 (36.825mm)	1.4598 (37.079mm)
-22	1.3750 (34.925mm)	1.5748 (40.000mm)	1.5848 (40.254mm)
-24	1.5000 (38.100mm)	1.7623 (44.762mm)	1.7723 (45.016mm)
-26	1.6250 (41.275mm)	1.8873 (47.937mm)	1.8973 (48.191mm)
-28	1.7500 (44.450mm)	2.0123 (51.112mm)	2.0223 (51.366mm)
-32	2.0000 (50.800mm)	2.2623 (57.462mm)	2.2723 (57.716mm)

Specification Compliance

Plating, Coating, and Surface Treatment	
Alodine	MIL-C-5541
Anodize (Chromic)	MIL-A-8625 TypeI Class I
Anodize (Sulphuric)	MIL-A-8625 TypeII Class I
Anodize (Hard)	MIL-A-8625 TypeIII Class I
Cadmium	AMS-QQ-P-416 Type I Class 3 (Races)
Cadmium (Supplementary Chromate) Treatment)	AMS-QQ-P-416 Type II Class 2 (Bodies)
Cadmium (Vacuum Deposited)	MIL-C-8837
Chromium	AMS-QQ-C-320 Class 2 (.0002" to .0005" thickness)
Chromium	AMS2406
Nickel (Electroless)	MIL-C-26074
Nickel (Electrodeposited)	QQ-N-290
Passivate	AMS 2700
Silver	AMS 2410
Zinc (Chromate Primer)	TT-P-1757 and MIL-P-8585
Heat Treatment	
Steel, Alloy and Stainless	AMS-H-6875 AMS2759
Aluminum	AMS-H-6088
Beryllium Copper	AMS-H-7199
Non-Destructive Testing	
Fluorescent Penetrant	ASTM E1417
Magnetic Particle	ASTM E1444
Ultrasonic	MIL-I-8950
Quality Control	
Quality Program Requirements	MIL-Q-9858
Inspection System Requirements	MIL-I-45208
Calibration System Requirements	MIL-C-45662
Sampling Procedures and Tables for Inspection by Attributes	ANSI/ASQC Z1.4
Machining	
Threads, Rolled or Turned	AS-8879 and MIL-S-7742
Marking and Packaging	
Commercial Packaging	MIL-STD-1188
Military Packaging	MIL-STD-129
Marking	MIL-STD-130
Preservation	MIL-P-116

INCH/METRIC CONVERSION FACTORS

INCH			INCH			INCH			INCH		
FRACT.	DECIMAL	mm	FRACT.	DECIMAL	mm	FRACT.	DECIMAL	mm	FRACT.	DECIMAL	mm
	.00004	0.001	¹⁷ / ₆₄	.2656	6.747		.6693	17.000		1.3780	35.000
	.0004	0.010		.2756	7.000	⁴³ / ₆₄	.6719	17.066		1.4173	36.000
	.0010	0.025	⁹ / ₃₂	.2812	7.142	¹¹ / ₁₆	.6875	17.462	¹ / ₂	1.5000	38.100
	.0020	0.051	¹⁹ / ₆₄	.2969	7.541	⁴⁵ / ₆₄	.7031	17.859		1.5354	39.000
	.0030	0.076	⁵ / ₁₆	.3125	7.938		.7086	18.000		1.5748	40.000
	.0039	0.100		.3150	8.000	²³ / ₃₂	.7187	18.255		1.6535	42.000
	.0050	0.127	²¹ / ₆₄	.3281	8.334	⁴⁷ / ₆₄	.7344	18.654	¹ / ₄	1.7500	44.450
	.0098	0.250	¹¹ / ₃₂	.3438	8.733		.7480	19.000		1.7717	45.000
	.0100	0.254		.3543	9.000	³ / ₄	.7500	19.050		1.8898	48.000
¹ / ₆₄	.0156	0.396	²³ / ₆₄	.3594	9.129	⁴⁹ / ₆₄	.7656	19.445		1.9685	50.000
¹ / ₃₂	.0312	0.793	³ / ₈	.3750	9.525	²⁵ / ₃₂	.7812	19.842	2	2.000	50.800
	.0394	1.000	²⁵ / ₆₄	.3906	9.921		.7874	20.000		2.0472	52.000
³ / ₆₄	.0469	1.191		.3937	10.000	⁵¹ / ₆₄	.7969	20.241		2.1654	55.000
	.0591	1.500	¹³ / ₃₂	.4062	10.317	¹³ / ₁₆	.8125	20.638		2.2047	56.000
¹ / ₁₆	.0625	1.588	²⁷ / ₆₄	.4219	10.716		.8268	21.000	² / ₄	2.2500	57.150
⁵ / ₆₄	.0781	1.984		.4331	11.000	⁵³ / ₆₄	.8281	21.034		2.3622	60.000
	.0787	2.000	⁷ / ₁₆	.4375	11.112	²⁷ / ₃₂	.8437	21.430	² / ₂	2.5000	63.500
³ / ₃₂	.0937	2.380	²⁹ / ₆₄	.4531	11.509	⁵⁵ / ₆₄	.8594	21.829		2.5197	64.000
	.0984	2.500	¹⁵ / ₃₂	.4687	11.905		.8661	22.000	² / ₄	2.7500	69.850
	.1000	2.540		.4724	12.000	⁷ / ₈	.8750	22.225		2.8346	72.000
⁷ / ₆₄	.1094	2.779	³¹ / ₆₄	.4844	12.304	⁵⁷ / ₆₄	.8906	22.621		2.9528	75.000
	.1181	3.000	¹ / ₂	.5000	12.700		.9055	23.000	3	3.0000	76.200
¹ / ₈	.1250	3.175		.5118	13.000	²⁹ / ₃₂	.9062	23.017		3.1496	80.000
	.1378	3.500	³³ / ₆₄	.5156	13.096	⁵⁹ / ₆₄	.9219	23.416	³ / ₄	3.2500	82.550
⁹ / ₆₄	.1406	3.571	¹⁷ / ₃₂	.5312	13.492	¹⁵ / ₁₆	.9375	23.812	³ / ₂	3.5000	88.900
⁵ / ₃₂	.1562	3.967	³⁵ / ₆₄	.5469	13.891		.9449	24.000		3.5433	90.000
	.1575	4.000		.5512	14.000	⁶¹ / ₆₄	.9531	24.209	³ / ₄	3.7500	95.250
¹¹ / ₆₄	.1719	4.366	⁹ / ₁₆	.5625	14.288	³¹ / ₃₂	.9687	24.605		3.9370	100.000
	.1772	4.500	³⁷ / ₆₄	.5781	14.684		.9843	25.000	4	4.0000	101.600
³ / ₁₆	.1875	4.762		.5906	15.000	⁶³ / ₆₄	.9844	25.004	⁴ / ₄	4.2500	107.950
	.1969	5.000	¹⁹ / ₃₂	.5937	15.080	1	1.0000	25.400		4.3307	110.000
¹³ / ₆₄	.2031	5.159	³⁹ / ₆₄	.6094	15.479		1.0630	27.000	⁴ / ₂	4.5000	114.300
⁷ / ₃₂	.2188	5.558	⁵ / ₈	.6250	15.875		1.1024	28.000		4.7244	120.000
¹⁵ / ₆₄	.2344	5.954		.6299	16.000		1.1811	30.000	⁴ / ₄	4.7500	120.650
	.2362	6.000	⁴¹ / ₆₄	.6406	16.271	¹ / ₄	1.2500	31.750	5.	5.0000	127.000
¹ / ₄	.2500	6.350	²¹ / ₃₂	.6562	16.667		1.2992	33.000	⁵ / ₂	5.5000	139.700

INCH/METRIC CONVERSION FACTORS

inches × 25.4 = Millimeters

Millimeters × 0.03937 = Inches

Sq. Inches × 6.4515 = Sq. Centimeters

Sq. Centimeters × 0.155 = Sq. inches

Pounds × 0.4536 = Kilograms

Kilograms × 2.2046 = Pounds

Lbs. Per In.² × 0.689 = N per cm²

N per cm² × 1.45 = Lbs. Per In.²

Pounds (Force) × 4.448 = Newtons

Newtons × 0.2248 = Pounds (Force)

Temperatuer Conversion (Approximate)

Degrees C = (Degrees F-32) (.5556)

Degress F = (Degrees C) (1.8) +32

NMB PART NUMBERING SYSTEM

This page is presented as an overall guide to the NMB Catalog Part Numbering System. Where conflict or exceptions appear to occur, use callouts specified on the individual product pages.

SPHERICAL BEARINGS

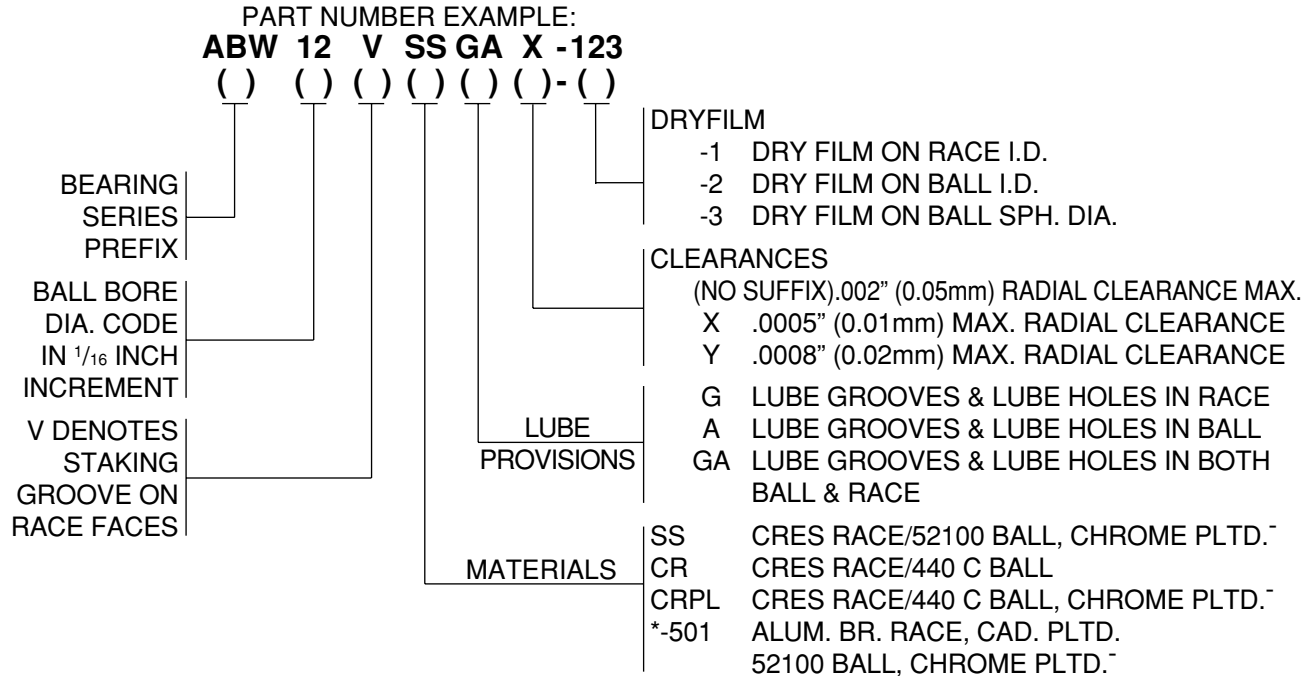

* When -501 suffix is applied it should follow all other suffixes except dry film. Example: ABW 8VGAX-501-123.

- Chrome plate callout as specified on standard 52100 & 440C balls applies to sph. dia. & ends only. Ball bores are plated only upon special request.

ROD END BEARINGS

