

Nominal Pressure	PN16	Test Medium
Shell Strength	(2.4MPa)	Water
Suitable Temp	-29~425 °C	
Media	Water/Steam/Oil	

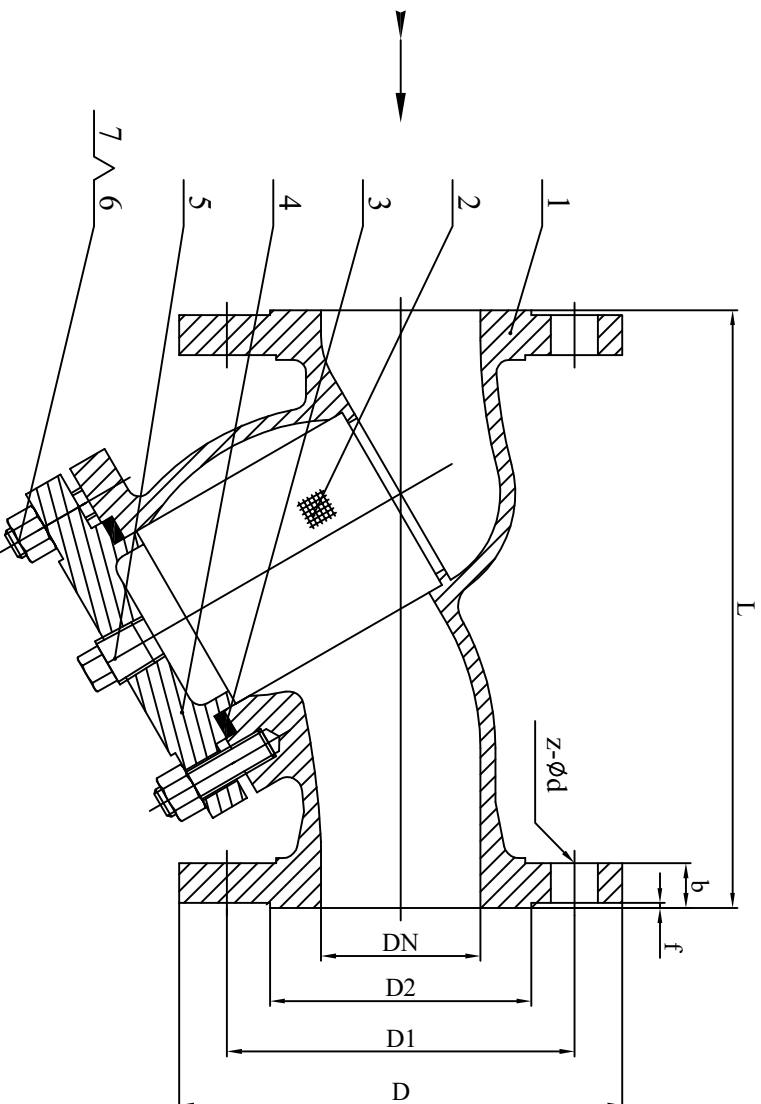

TECHNICAL SPECIFICATION

1. Design & Manufacture: Manufacturer's standard
3. Face-to-face dimension: Manufacturer's standard
4. RF Flanged: EN1092-1:2007 RF
5. Pressure Test: AP1598

DN	d	L	D	D1	D2	b	z-φd	f	H≈
50	φ50	203	φ165	φ125	φ102	18	4-φ18	3	
65	φ65	216	φ185	φ145	φ122	18	8-φ18	3	
80	φ80	241	φ200	φ160	φ138	20	8-φ18	3	
100	φ100	292	φ220	φ180	φ158	20	8-φ18	3	
125	φ125	356	φ250	φ210	φ188	22	8-φ18	3	
150	φ150	406	φ285	φ240	φ212	22	8-φ22	3	
200	φ200	495	φ340	φ295	φ268	24	12-φ22	3	
250	φ250	622	φ405	φ355	φ320	26	12-φ26	3	
300	φ300	698	φ460	φ410	φ378	28	12-φ26	4	
350	φ350	787	φ520	φ470	φ438	30	16-φ26	4	

07	Cover Nut	A194 2H/8
06	Cover Bolt	A193 B7/B8
05	Sewage bolts	A105/S.S
04	Bonnet	1.0619/1.4308/1.4408
03	Gasket	S.S+Graphite
02	Screen	SS304/SS316
01	Body	1.0619/1.4308/1.4408
No:	Part Name	Material List
Client: CX FLUID PRODUCTS MFG		
Contract: CO.,LTD.		
DN:(mm)		Y-Type strainer
Quantity:		Designer: Jim
Weight:		Date:2017.02.22
		Drawing: