



# DISC CHECK VALVE



## FEATURES

- 1/2"~8" (DN15~DN200)
- W.P. : PN40
- W.T. : -20°C~200°C (-4°F~392°F)
- Investment casting

- 1/4"~4" (DN8~DN100)
- W.P. : PN63
- W.T. : -20°C~200°C (-4°F~392°F)
- Investment casting
- End connection - Socket Weld End  
Butt Weld End  
Screwed End

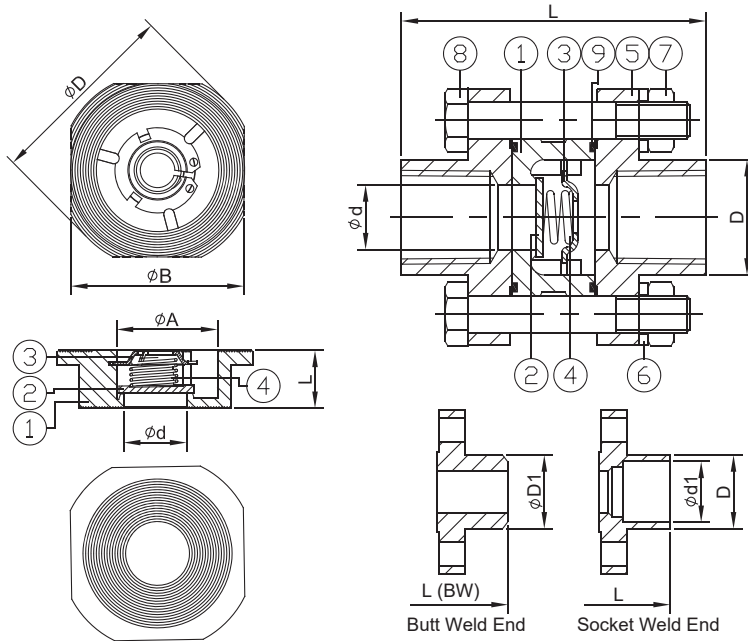

ITEM	PARTS	MATERIAL	
1	BODY	ASTM A351-CF8M/ 1.4408	ASTM A216-WCB/ 1.0619
2	SPRING HOLDER	AISI 316	AISI 304
3	DISC		
4	SPRING		
5	END CAP	ASTM A351-CF8M/ 1.4408	ASTM A216-WCB/ 1.0619
6	WASHER	AISI 304	
7	NUT		
8	BOLT		
9	SEAL	PTFE	

DN	d	A	L	B	D	Weight (Kg)
15	12.5	34	16	44.6	54	0.1
20	20	39	19	54	62	0.2
25	25	46	22	65	73	0.2
32	32	60	28	78	83	0.4
40	38	70	31.5	88	93	0.6
50	49	79	40	101.6	107	0.8
65	64	101	46	120.4	126.5	1.4
80	78	109	49	133	141.2	2
100	98	134	60	164	171.4	3
125	110	190	90	-	-	10
150	130	218	105	-	-	13
200	170	273	140	-	-	24

DN	d	d1	L	L (BW)	D1	D	Weight (kg)
8	10	14.2	60	66	12	22	0.3
10	10	17.5	60	66	12	22	0.2
15	14	21.8	63	67	14	26	0.4
20	19	27.4	71	81	16	32	0.5
25	25	34.1	81.5	89.5	16	39	0.7
32	31	42.7	91	92	18	49	1.3
40	39	49	97.5	103.5	18	56	1.7
50	49	61	117	117	18	69	2.5
65	64	77	131.5	131.5	18	83	4.3
80	78	90.2	143.5	143.5	18	100	6.2
100	97	115.3	174.5	174.5	18	122.5	11

NPS	d	A	L	B	D	Weight (lb)
1/2"	0.49	1.34	0.63	1.76	2.13	0.2
3/4"	0.79	1.54	0.75	2.13	2.44	0.4
1"	0.98	1.81	0.87	2.56	2.87	0.4
1-1/4"	1.26	2.36	1.1	3.07	3.27	0.9
1-1/2"	1.5	2.76	1.24	3.46	3.66	1.3
2"	1.93	3.11	1.57	4	4.21	1.8
2-1/2"	2.52	3.98	1.81	4.74	4.98	3.1
3"	3.07	4.29	1.93	5.24	5.56	4.4
4"	3.86	5.28	2.36	6.46	6.75	6.6
5"	4.33	7.48	3.54	-	-	22
6"	5.12	8.58	4.13	-	-	28.7
8"	6.69	10.75	5.51	-	-	52.9

NPS	d	d1	L	L (BW)	D1	D	Weight (lb)
1/4"	0.39	0.56	2.36	2.6	0.47	0.87	0.6
3/8"	0.39	0.69	2.36	2.6	0.47	0.87	0.5
1/2"	0.55	0.86	2.48	2.64	0.55	1.02	0.8
3/4"	0.75	1.08	2.8	3.19	0.63	1.26	1.1
1"	0.98	1.34	3.21	3.52	0.63	1.54	1.6
1-1/4"	1.22	1.68	3.58	3.62	0.71	1.93	2.8
1-1/2"	1.54	1.93	3.84	4.07	0.71	2.2	3.7
2"	1.93	2.4	4.61	4.61	0.71	2.72	5.4
2-1/2"	2.52	3.03	5.18	5.18	0.71	3.27	9.5
3"	3.07	3.55	5.65	5.65	0.71	3.94	14
4"	3.82	4.54	6.87	6.87	0.71	4.82	24.3

Add: Shacheng Industrial Park, Longwan District, Wenzhou City 325025, Zhejiang Province, China

Tel/Fax: +86-577-8986-3679 Mobile: +86 189 5773 1879

<http://www.cncxvalve.com>

Email: [sales@cncxvalve.com](mailto:sales@cncxvalve.com)