

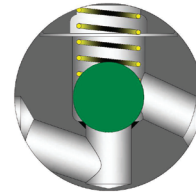

API 602 PISTON CHECK VALVES
FORGED CARBON, STAINLESS STEEL OR ALLOY STEEL
¼" TO 2" (6 TO 50 mm)
ASME CLASSES 150 TO 2680

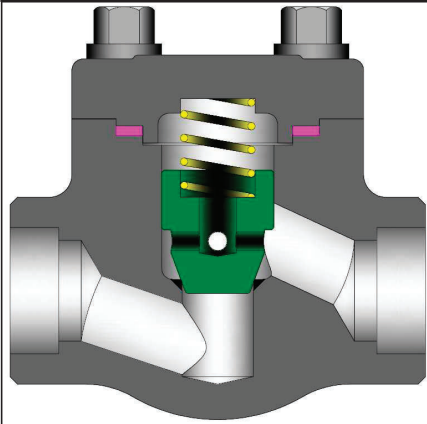

Ball Check

STANDARD MATERIALS (Other materials available)

Class	Bore	Fig. No.	
		Piston	Ball
150	Standard	PC01	BC01
	Full	PCL1	BCL1
300	Standard	PC03	BC03
	Full	PCL3	BCL3
600	Standard	PC06	BC06
	Full	PCL6	BCL6
800	Standard	PC08	BC08
	Full	PCL8	BCL8
1500	Standard	PC15	BC15
	Full	PCL5	BCL5
1680	Standard	PC16	BC16
2500	Standard	PC25	BC25
2690	Standard	PC26	BC26

PART	MATERIALS			
Body	A105 + Stellite 6 Faced	A182 F11 + Stellite 6 Faced	A182 F22 + Stellite 6 Faced	A182 F316 (1)
Cap	A105	A182 F11	A182 F22	A182 F316
Disc/Ball	A276 T420			A276 T316
Gasket (2)	Spiral Wound SST with Graphite			Spiral Wound SST with PTFE
Spring	Inconel 625			
Body / Cap Bolting (2)	A193 Gr. B7	A193 Gr. B16		A193 Gr. B8M
Identification Plate	Series 300 SST			

DESIGN FEATURES:

- **Standard trim** is stellite faced seat integral to the body and 13% chrome disc/ball (API trim 8). Other trims available on request.
- **Seat faces** lapped for smooth finish and superior sealing.
- **Wall thickness** per heavy wall API 602 requirements.
- **Each valve** is shell and seat pressure tested per industry standard API 598.
- **Check valve** are suitable for service in horizontal line with cap vertical.
- **End Flanges** have the following raised faces per ASME B16.5:
Classes 150-300: 1/16" (2mm).
Classes 600: 1/4" (7mm).
- **Other available options** as follows:
-Alternate valve materials such as chrome and stainless steel alloys.
-Alternate trim materials.
-NACE service.
-Special cleaning for applications such as oxygen or chlorine.
-Other options available as specified.

- (1) Threaded and weld end valve bodies A182 F316L
- (2) Welded bonnets also available.

Design Specifications

Item	Applicable Specification
Wall thickness	API 602
Pressure - temperature ratings	ASME B16.34
General valve design	API 602 & B16.34
End to End dimensions	ASME B16.10
Flange design	ASME B16.5
Thread design	ASME B1.20.1
Butt Weld design	ASME B16.25
Socket Weld design	ASME B16.11
Materials	ASTM

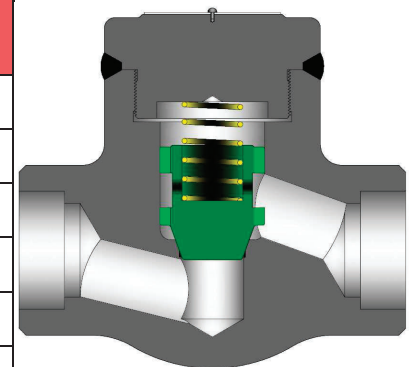

Welded Bonnet Design

PISTON CHECK VALVE DIMENSIONS (CLASS 150—800).

SIZE	ASME 150			ASME 300			ASME 600		
	Bolted Bonnet			Bolted Bonnet			Bolted Bonnet		
	Standard Bore			Standard Bore			Standard Bore		
in	A	C	D	A	C	D	A	C	D
mm	FE			FE			FE		
½	4.25	2.2	0.39	6.00	2.2	0.39	6.50	2.2	0.39
13	108	55	10	152	55	10	165	55	10
¾	4.62	2.2	0.50	7.00	2.2	0.50	7.50	2.2	0.50
19	117	55	13	178	55	13	190	55	13
1	5.00	2.8	0.69	8.00	2.8	0.69	8.50	2.8	0.69
25	127	72	18	203	72	18	216	72	18
1¼	5.50	3.2	0.91	8.50	3.2	0.91	9.00	3.2	0.91
32	140	81	23	216	81	23	229	81	23
1½	6.50	3.6	1.12	9.00	3.7	1.12	9.50	3.7	1.12
38	165	91	29	229	94	29	241	94	29
2	8.00	4.4	1.26	10.50	4.4	1.38	11.50	4.4	1.38
50	203	112	32	267	112	35	292	112	35

SIZE	ASME 800											
	Bolted Bonnet						Welded Bonnet					
	Standard Bore			Full Bore			Standard Bore			Full Bore		
in	A	C	D	A	C	D	A	C	D	A	C	D
mm	WE			WE			WE			WE		
¼	3.11	2.2	0.26	-	-	-	3.11	2.2	0.26	-	-	-
6	79	55	7	-	-	-	79	55	7	-	-	-
¾	3.11	2.2	0.39	-	-	-	3.11	2.2	0.39	-	-	-
10	79	55	10	-	-	-	79	55	10	-	-	-
½	3.11	2.2	0.39	3.62	2.2	0.50	3.11	2.2	0.39	3.62	2.2	0.50
13	79	55	10	92	55	13	79	55	10	92	55	13
¾	3.62	2.2	0.50	4.37	3.0	0.69	3.62	2.2	0.50	4.37	3.0	0.69
19	92	55	13	111	72	18	92	55	13	111	72	18
1	4.37	3.0	0.69	4.72	3.2	0.91	4.37	3.0	0.69	4.72	3.2	0.91
25	111	72	18	120	81	23	111	72	18	120	81	23
1¼	4.72	3.2	0.91	5.98	3.7	1.12	4.72	3.2	0.91	5.98	3.7	1.12
32	120	81	23	152	94	29	120	81	23	152	94	29
1½	5.98	3.7	1.12	6.77	4.4	1.40	5.98	3.7	1.12	6.77	4.4	1.42
38	152	94	29	172	112	36	152	94	29	172	112	36
2	6.77	4.4	1.38	8.66	5.2	1.85	6.77	4.4	1.38	8.66	5.2	1.85
50	172	112	35	220	132	47	172	112	35	220	132	47

**ADDITIONAL MATERIALS
AND CLASSES AVAILABLE
UPON REQUEST.**

WE = Socket Weld / Threaded Ends
FE = Flanged Ends
C = Center to top

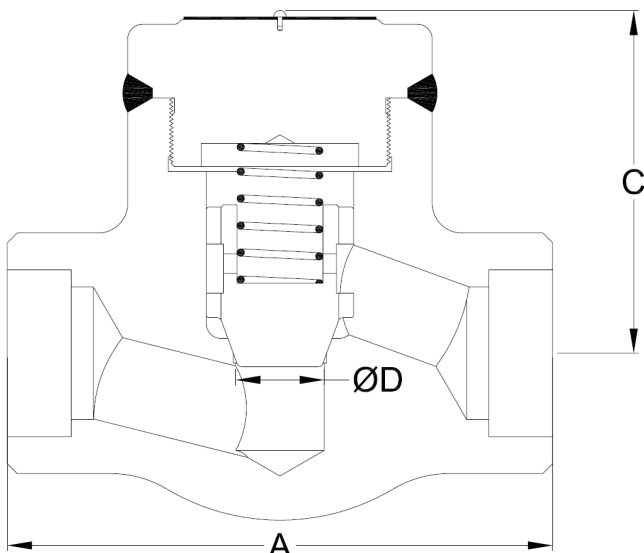

Welded Bonnet Socket Weld Ends Design

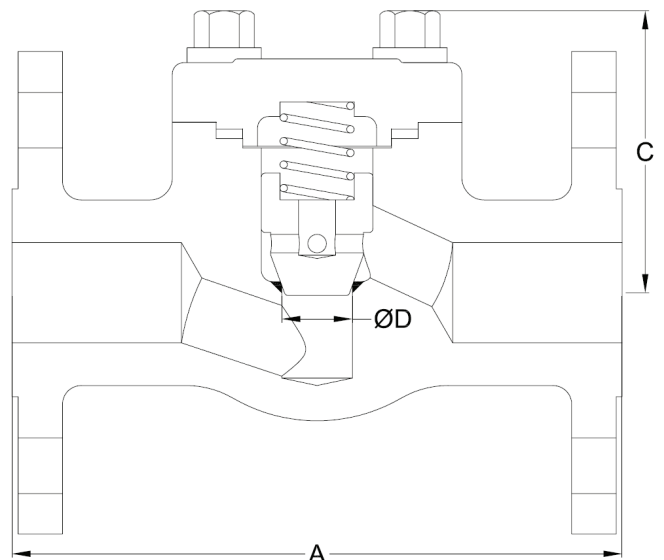

Bolted Bonnet Flanged Ends Design

PISTON CHECK VALVE DIMENSIONS (CLASS 1500—2680).

SIZE	ASME 1500 & 1690												
	Bolted Bonnet						Welded Bonnet						
	Standard Bore			Full Bore			Standard Bore			Full Bore			
	A		C	D	A		C	D	A		C	D	
FE	WE	WE			FE	WE							
¼	-	3.11	2.9	0.26	-	-	-	3.11	2.9	0.39	-	-	-
6	-	79	73	7	-	-	-	79	73	10	-	-	-
¾	-	3.11	2.9	0.39	-	-	-	3.11	2.9	0.50	-	-	-
10	-	79	73	10	-	-	-	79	73	13	-	-	-
½	8.50	3.62	2.9	0.39	4.37	2.9	0.50	3.62	2.9	0.39	4.37	2.9	0.50
13	216	92	73	10	111	73	13	92	73	10	111	73	13
¾	9.00	4.37	2.9	0.50	4.72	3.3	0.69	4.37	2.9	0.51	4.72	3.3	0.69
19	229	111	73	13	120	84	18	111	73	13	120	84	18
1	10.00	4.72	3.3	0.69	5.98	3.8	0.91	4.72	3.3	0.69	5.98	3.8	0.91
25	254	120	84	18	152	97	23	120	84	18	152	97	23
1¼	11.00	5.98	3.8	0.91	6.77	4.5	1.12	5.98	3.8	0.91	6.77	4.5	1.12
32	279	152	97	23	172	115	29	152	97	23	172	115	29
1½	12.00	6.77	4.5	1.12	8.66	5.2	1.38	6.77	4.5	1.12	8.66	5.2	1.38
38	305	172	115	29	220	132	35	172	115	29	220	132	35
2	14.50	8.66	5.2	1.38	9.84	5.2	1.85	8.66	5.2	1.38	10.24	5.2	1.85
50	368	220	132	35	250	132	47	220	132	35	260	132	47

SIZE	ASME 2500 & 2680							
	Bolted Bonnet			Welded Bonnet				
	Standard Bore			Standard Bore				
	A		C	D	A		C	D
WE	FE	WE			FE			
½	5.91		4.0	0.43	5.91		5.3	0.55
13	150		102	11	150		135	14
¾	5.91		4.0	0.43	5.91		5.3	0.55
19	150		102	11	150		135	14
1	6.69		4.2	0.55	6.69		5.7	0.75
25	170		107	14	170		146	19
1¼	7.87		5.0	0.63	7.87		6.9	0.98
32	200		128	16	200		176	25
1½	7.87		5.0	0.98	7.87		6.9	1.10
38	200		128	25	200		176	28
2	9.84		5.6	1.10	9.84		7.7	1.38
50	250		143	28	250		196	35

ADDITIONAL MATERIALS AND CLASSES AVAILABLE UPON REQUEST.

WE = Socket Weld / Threaded Ends
FE = Flanged Ends
C = Center to top open

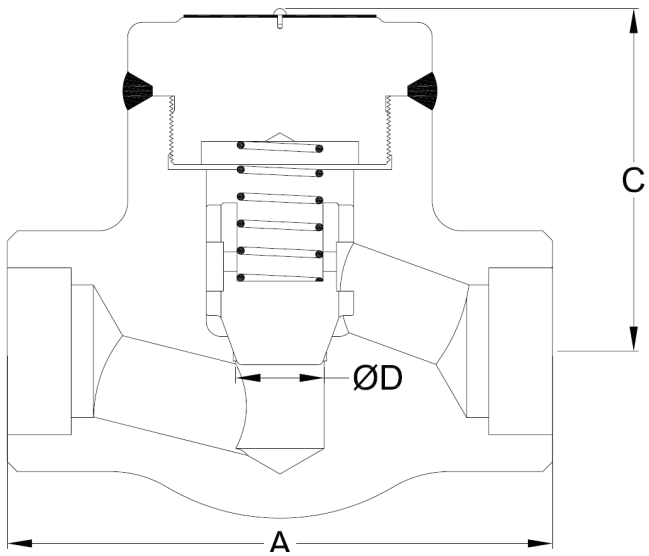

Welded Bonnet Socket Weld Ends Design

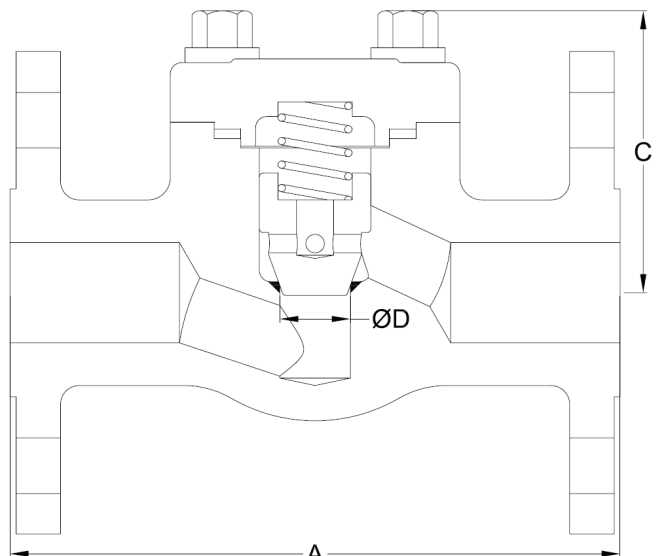

Bolted Bonnet Flanged Ends Design



API 602 PISTON CHECK VALVES
 FORGED CARBON , STAINLESS STEEL OR ALLOY STEEL
 ¼” TO 2” (6 TO 50 mm)
 ASME CLASSES 150 TO 2680

SIZE	ASME 150			ASME 300			ASME 600			ASME 800											
	Bolted Bonnet			Bolted Bonnet			Bolted Bonnet			Bolted Bonnet						Welded Bonnet					
	Standard Bore			Standard Bore			Standard Bore			Standard Bore			Full Bore			Standard Bore			Full Bore		
in	WT	LB	C _v	WT	LB	C _v	WT	LB	C _v	WT	LB	C _v	WT	LB	C _v	WT	LB	C _v	WT	LB	C _v
mm	FE	KG		FE	KG		FE	KG		WE	KG		WE	KG		WE	KG		WE	KG	
¼	-	-	-	-	-	-	-	-	-	3.3	0.7	-	-	3.1	0.7	-	-	-	-	-	-
6	-	-	-	-	-	-	-	-	-	1.5	-	-	-	1.4	-	-	-	-	-	-	-
¾	-	-	-	-	-	-	-	-	-	3.3	1.5	-	-	3.1	1.5	-	-	-	-	-	-
10	-	-	-	-	-	-	-	-	-	1.5	-	-	-	1.4	-	-	-	-	-	-	-
½	7.5	1.5	-	8.2	1.5	-	7.5	1.5	-	3.1	1.5	-	4.2	2.6	-	3.1	1.5	-	4.2	2.6	-
13	3.4	-	-	3.7	-	-	3.4	-	-	1.4	-	-	1.9	-	-	1.4	-	-	1.9	-	-
¾	9.7	2.7	-	10.6	2.7	-	12.8	2.7	-	4.2	2.7	-	5.7	4.9	-	4.0	2.7	-	5.7	4.9	-
19	4.4	-	-	4.8	-	-	5.8	-	-	1.9	-	-	2.6	-	-	1.8	-	-	2.6	-	-
1	18.1	5.1	-	19.4	5.1	-	20.9	5.1	-	5.7	5.1	-	9.3	8.9	-	5.7	5.1	-	9.3	8.9	-
25	8.2	-	-	8.8	-	-	9.5	-	-	2.6	-	-	4.2	-	-	2.6	-	-	4.2	-	-
1¼	19.6	9.1	-	21.2	9.1	-	22.9	9.1	-	9.3	9.1	-	11.7	13.7	-	9.3	9.1	-	11.7	13.7	-
32	8.9	-	-	9.6	-	-	10.4	-	-	4.2	-	-	5.3	-	-	4.2	-	-	5.3	-	-
1½	26.5	14.0	-	30.2	14.0	-	34.4	14.0	-	11.7	14.0	-	19.8	21.9	-	11.7	14.0	-	19.8	21.9	-
38	12.0	-	-	13.7	-	-	15.6	-	-	5.3	-	-	9.0	-	-	5.3	-	-	9.0	-	-
2	31.5	22.4	-	39.2	22.4	-	54.0	22.4	-	19.8	22.4	-	34.4	40	-	19.8	22.4	-	34.4	40	-
50	14.3	-	-	17.8	-	-	24.5	-	-	9.0	-	-	15.6	-	-	9.0	-	-	15.6	-	-

SIZE	ASME 1500 & 1687												ASME 2500 & 2680								
	Bolted Bonnet						Welded Bonnet						Bolted Bonnet			Welded Bonnet					
	Standard Bore			Full Bore			Standard Bore			Full Bore			Standard Bore			Standard Bore					
in	WT	LB	WT	LB	C _v	WT	LB	C _v	WT	LB	C _v	WT	LB	C _v	WT	LB	C _v	WT	LB	C _v	
mm	FE	KG	WE	KG		WE	KG		WE	KG		WE	KG		WE	KG		WE	KG		
¼	-	-	4.9	-	0.7	-	-	-	4.9	-	0.7	-	-	-	-	-	-	-	-	-	-
6	-	-	2.2	-	-	-	-	-	2.2	-	-	-	-	-	-	-	-	-	-	-	-
¾	-	-	4.9	-	1.5	-	-	-	4.9	-	1.5	-	-	-	-	-	-	-	-	-	-
10	-	-	2.2	-	-	-	-	-	2.2	-	-	-	-	-	-	-	-	-	-	-	-
½	20.7	-	5.3	-	1.5	6.4	-	1.5	5.3	-	1.5	6.4	-	1.5	17.6	-	1.8	15.4	-	3.0	-
13	9.4	-	2.4	-	-	2.9	-	-	2.4	-	-	2.9	-	-	8.0	-	-	7.0	-	-	-
¾	24.7	-	6.4	-	2.7	10.1	-	2.7	6.4	-	2.7	10.1	-	2.7	17.2	-	1.9	15.0	-	3.1	-
19	11.2	-	2.9	-	-	4.6	-	-	2.9	-	-	4.6	-	-	7.8	-	-	6.8	-	-	-
1	31.7	-	10.1	-	5.1	14.3	-	5.1	10.1	-	5.1	14.3	-	5.1	26.5	-	3.2	24.3	-	6.0	-
25	14.4	-	4.6	-	-	6.5	-	-	4.6	-	-	6.5	-	-	12.0	-	-	11.0	-	-	-
1¼	35.3	-	14.3	-	9.1	23.1	-	9.1	14.3	-	9.1	23.1	-	9.1	43.0	-	4.3	39.7	-	10.5	-
32	16.0	-	6.5	-	-	10.5	-	-	6.5	-	-	10.5	-	-	19.5	-	-	18.0	-	-	-
1½	47.4	-	23.1	-	14.0	34.4	-	14.0	23.1	-	14.0	34.4	-	14.0	42.5	-	10.7	39.0	-	13.5	-
38	21.5	-	10.5	-	-	15.6	-	-	10.5	-	-	15.6	-	-	19.3	-	-	17.7	-	-	-
2	61.7	-	34.2	-	22.4	37.5	-	22.4	34.2	-	22.4	37.5	-	22.4	59.5	-	14.2	63.9	-	22.4	-
50	28.0	-	15.5	-	-	17.0	-	-	15.5	-	-	17.0	-	-	27.0	-	-	29.0	-	-	-

FE = Flanged Ends
WE = Socket Weld / Threaded Ends

WT = Weight
C_v = Flow Coefficient